

تم تحميل هذا الملف من موقع المناهج الإماراتية



مراجعة عامة منهج انسابير

موقع المناهج ← المناهج الإماراتية ← الصف الرابع ← علوم ← الفصل الثاني ← ملفات متنوعة ← الملف

تاريخ إضافة الملف على موقع المناهج: 08:36:18 2025-03-01

ملفات اكتب للمعلم اكتب للطالب الاختبارات الكترونية | اختبارات | حلول | عروض بوربوينت | أوراق عمل
منهج انجليزي | ملخصات وتقارير | مذكرات وبنوك | الامتحان النهائي للمدرس

المزيد من مادة
علوم:

إعداد: Messabi Al Arwa

التواصل الاجتماعي بحسب الصف الرابع



صفحة المناهج
الإماراتية على
فيسبوك

الرياضيات

اللغة الانجليزية

اللغة العربية

التربية الاسلامية

المواد على تلغرام

المزيد من الملفات بحسب الصف الرابع والمادة علوم في الفصل الثاني

حل أسئلة مراجعة نهائية منهج انسابير

1

أسئلة مراجعة نهائية منهج انسابير

2

حل مراجعة نهائية وفق الهيكل الوزاري

3

أوراق عمل مراجعة منهج انسابير

4

حل أوراق عمل مراجعة عامة

5

Reefaa School

ST name: 4\

Thermal Energy:

1-Thermal energy is:

- a-The external energy of an object due to its potential energy**
- b-The internal energy of an object due to the kinetic energy of its particles**
- c-The internal energy of an object due to the stored energy of its particles**

2- What happened if you put metal spoon in cup of hot soup?

- a-Spoons begin heating up when they are placed into liquids.**
- c-Thermal energy is transferred from the hot soup to the spoon.**
- d-Heat is created when metals and glasses combine with one another.**

3-The stove, heater and match can all produce energy:

- a- Light**
- b-Thermal**
- c-Sound**

4-What happened to the thermal energy when substance get warmer or hotter?

- a-Decrease**
- b- Increase**
- c-Nothing**

5-Thermal energy it kind of : **a-Potential energy** **b-Stored energy** **c-Kinetic energy**

6-Burning wood its type of chemical energy that stored energy and released it when wood burning as energy.

- a-Thermal**
- b- Nuclear**
- c-Electricity**

Electrical Energy:

1- Type of energy come from movement charged particles or chemical energy that stored in batteries.

- A-Nuclear**
- b-Light**
- c-Electricity**

2- What type of energy does the electrical energy become in iron مكواة:

- a-Light energy**
- b-Thermal energy**
- c-Nuclear energy**

3- The lightbulb changes electrical energy into light energy. This is an example of?

- a-Energy transformation**
- b- Energy exchange**
- c-Energy being created**

4-Chemical energy inside batteries change into when they used in devices:

- a-Sound**
- b- Nuclear**
- c-Electricity**

5-Most of our electricity come from power plant which burn To make electricity.

- a-Fuel**
- b-wood**
- c-metal**

6-How energy change in a toaster?

a-Chemical to thermal

b-Electrical to light

c-Electrical to thermal

7-Put correct number in

1-Chemical to electrical

2-Motion to sound

3-Light to thermal

empty place:

.....Sunlight heats the sidewall

.....Battery powered flashlight

.....Beating the drum

Sound Energy:

1- Wave that transfers energy through a material and spreads outward in all directions from a vibration. **a-Light wave** **b-Electricity** **c-Sound wave**

2-In space sound **cannot** hear because of:

a-No air in space, so there is no medium to carry sound waves.

b-Space is a vacuum with no particles to travel through.

C- All of them.

3-Sound is:

a-vibrations

b-Series of compressions and rarefactions

c-Waves

d-all of them.

4- Substance where sound can travel:

a-Medium

b-cell

c-wave

5- Arrange these items according to the speed of sound 1 is fastest:

(.....) **Ais as gas**

(.....) **Water as liquid**

(.....) **Steel as Solid.**

6-Why sound travel fastest in solid?

a-Partials are close together, so they collide quickly.

b-Partials are far apart so they collide quickly.

c-Partials little close together so they no collide quickly.

7-Sound waves are:

a-Longitudinal waves

b-Transvers waves

c-Seismic wave

Light and Stored energy:

1-Light energy is:

a- Wave

b-Particles

c- Kinetic

d-All of them.

2-Light energy travel fastest through:

a-Glass

b-Vacuum space

c-Water

3-Firewark stored their potential energy in:

a-Nuclear

b-Chemical

c-Fuel

4-When firework goes off energy release as:

a-Heat, nuclear

b-Light, sound, thermal

c-Chemical, thermal, electrical

Electricity Current: 1-Connect each part of circuit to its roll in electrical circuit:

- 1- Battery
- 2- Lightbulb
- 3- Wire
- 4- Switch

- A-(.....)Object resist flow of energy
- B-(.....)Open and close circuit path
- C-(.....)Voltage source
- D-(.....) Carry electrical charge between all parts of circuit.

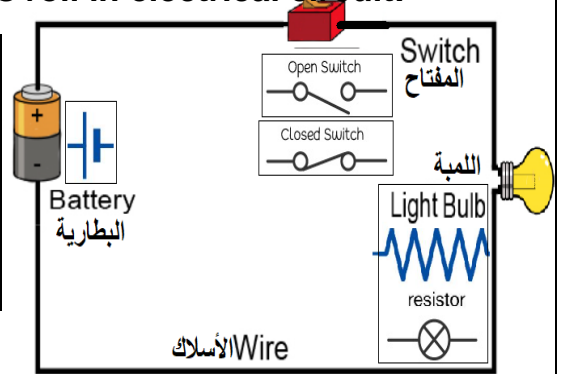

2- Connect switch job in electrical circuit correctly: وظيفة المفتاح في الدائرة الكهربائية:

- 1-Switch Open
- 2-Switch Close

- A(.....) Circuit close so electrical current flow
- B(.....) Circuit open so **No** electrical current flow.

3-Look to picture of Simple Circuit then answer:

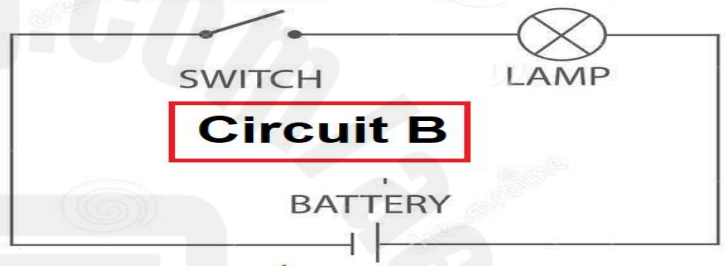
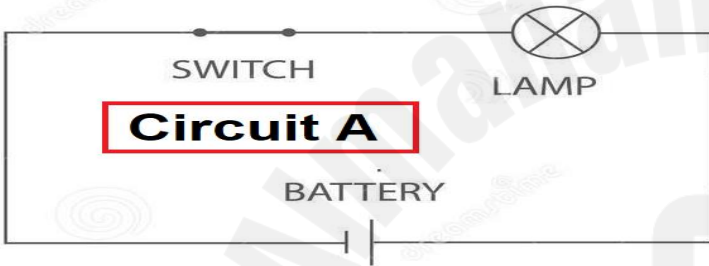

1-In which circuit electrical current Dose Not flow? A-Circuit A B-Circuit B

2-In which circuit electrical current will flow? A-Circuit A B-Circuit B

3-How do you know that circuit A close and electrical current will flow? **Because ...**

a-Switch is close

b-Switch is open

c-Battery is fall

4-Look to this picture:

A-Circuit A is

B-Circuit B is

- Series
- Parallel

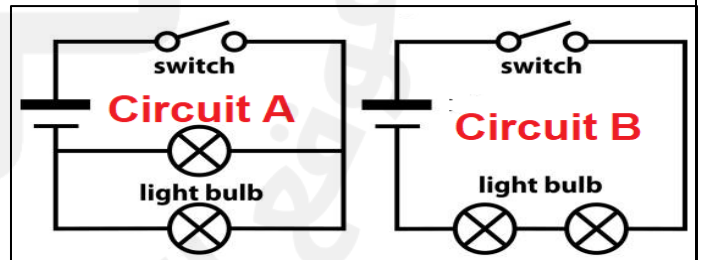

Heat: 1- Write correct latter in its place meaning of each one of heat transfer:

- | | | |
|--|--|---|
| 1-Transfer way in which heat can transfer in space (.....) | 2-The transfer of energy between two solid objects that are touching (.....) | 3-The transfer of energy in moving gases or liquids (.....) |
|--|--|---|

A - Radiation

B - Conduction

C - Convection

2-Write correct number near each way of heat

- transfer: 1- (.....) Radiation
 2- (.....) Convection
 3- (.....) Conduction

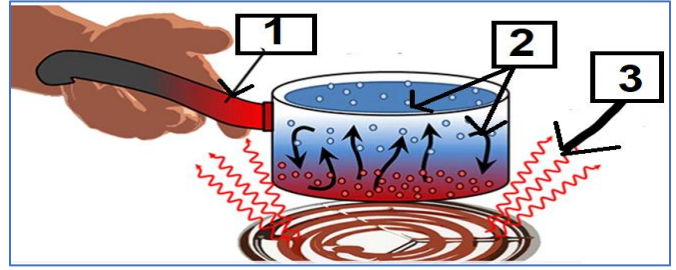

Nonrenewable Resources: Put correct number up each type of energy resource:1 OR 2

1- Nonrenewable resources

2- Renewable resources

Oil النفط	Nuclear النووي	Wind الرياح	solar power الطاقة الشمسية	Natural Gas غاز طبيعي	Coal الفحم	Hydropower طاقة المبهاء	Metal المعادن

2- A material that formed from ancient organisms and is used today as a source of energy is:

- a- Fossil fuel b- Sediment c- Alternative energy resource

3-The fossil fuel are: a-Natural gas b-Oil c-Coal d-all of them

4-Join each type of nonrenewable resources to its Using:

1-Nuclear	(.....) , (.....), (.....) Produce Electricity
2-Oil	(.....) Power steam engines.
3-Natural gas	(.....) Cook food and Heating
4-Coal	

5-Wind energy, water energy, and solar power are all examples of energy solutions.

- a-alternative or Renewable b- Nonrenewable c-Fossil fuels

6-Which method is used to change plant and animal materials into fuel?

- a-Hydroelectricity b- Recycling c-Biomass conversion

7-Choose all types of renewable energy resources:

- a-Solar b-Oil c-Hydropower d-Wind e-Coal f-Geothermal g-Biofuel

8-Join each type of renewable resources to its Using and energy kind:

1-Biofuel	Using form أشكال الاستخدام	Energy kind نوع الطاقة
2-Solar power	(.....) , (.....), (.....), (.....) Produce Electricity	(.....) , (.....), (.....), (.....) Kinetic energy of motion
3-Geothermal	(.....) Thermal, fuel and Gas	(.....) Poetical stored energy
4-Hydroelectricity		
5-Wind Energy		

Impact of using energy:

1-Burning oil as fuel can release harmful substances called

- a- Conservation b- Pollution c- Recycling

2- Any harmful substance that affect Earth's land, air, water:

- a- Conservation b- Pollution c- Recycling

3-Reducing the amount of resources we use, called , will allow resources to be saved for a later time. a-Conservation b- Pollution c- Recycling.

4- The overuse of fossil fuels leads to a-Flooding b-Pollution c- Fertile soil

5-How can we conserve energy and help protect our environment:

a-Turn off water, turn off lights, turn off TV. a- Using less energy c-all of them

6-When an item is it is made into a new product.

- a- Reused b- Recycled c- Reduce

7- To use something more than once. a- Reused b- Recycled c- Reduce

8- To less the amount of something is used. a-Recycled b- Reused c-Reduce

Classify each type of energy in to correct number: صنف كل أنواع الطاقة الى رقمها الصحيح

1-Pollution Environment ملوث البيئة

2- Not Pollution Environment غير ملوث

Nuclear Energy نووية	Natural Gas غاز	Oil بتترول	Solar Energy شمسية	Hydroelectricity كهرومائية	Wind Energy الرياح	Coal الفحم	Geothermal Energy حرارية جوفية	Biofuel وقود حيوي
-------------------------	--------------------	---------------	-----------------------	-------------------------------	-----------------------	---------------	-----------------------------------	----------------------

Design Energy solution:

1-Which method of powering a vehicle will help to reduce air pollution

- a- Using oil b- Using biofuels c- Using gasoline

2-How does the solar panel solve a design problem?

- a- It transforms energy without producing air pollution.
b- It transforms sunlight energy to wind energy.
c- It uses nonrenewable resources for power.

3- Why now many people like LED lightbulb?

- a-Give more light less heat. B-Give more heat less light c-I don't like LED

أرجو لكم التوفيق والنجاح معلمة العلوم الأستاذة **أروى المصعبي** ... مدرسة رفاعة – العين

I hope you success and achieve.... Science teacher Ms. **Arwa Al-Messabi**