

تم تحميل هذا الملف من موقع المناهج البحرينية



* للحصول على أوراق عمل لجميع الصفوف وجميع المواد اضغط هنا

<https://almanahj.com/bh>

* للحصول على أوراق عمل لجميع مواد الصف الحادي عشر اضغط هنا

<https://almanahj.com/bh/11>

* للحصول على جميع أوراق الصف الحادي عشر في مادة فيزياء وجميع الفصول, اضغط هنا

<https://almanahj.com/bh/11physics>

* للحصول على أوراق عمل لجميع مواد الصف الحادي عشر في مادة فيزياء الخاصة بـ الفصل الأول اضغط هنا

<https://almanahj.com/bh/11physics1>

* لتحميل كتب جميع المواد في جميع الفصول للـ الصف الحادي عشر اضغط هنا

<https://almanahj.com/bh/grade11>

[almanahjbhbot/me.t//:https](https://t.me/almanahjbhbot)

للتحدث إلى بوت على تلغرام: اضغط هنا

Practice Problems

5.1 Vectors

pages 119–125

page 121

1. A car is driven 125.0 km due west, then 65.0 km due south. What is the magnitude of its displacement? Solve this problem both graphically and mathematically, and check your answers against each other.

$$R^2 = A^2 + B^2$$

$$R = \sqrt{A^2 + B^2}$$

$$= \sqrt{(65.0 \text{ km})^2 + (125.0 \text{ km})^2}$$

$$= 141 \text{ km}$$

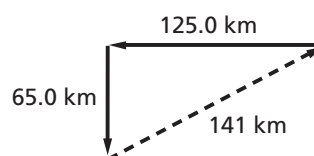

2. Two shoppers walk from the door of the mall to their car, which is 250.0 m down a lane of cars, and then turn 90° to the right and walk an additional 60.0 m. What is the magnitude of the displacement of the shoppers' car from the mall door? Solve this problem both graphically and mathematically, and check your answers against each other.

$$R^2 = A^2 + B^2$$

$$R = \sqrt{A^2 + B^2}$$

$$= \sqrt{(250.0 \text{ m})^2 + (60.0 \text{ m})^2}$$

$$= 257 \text{ m}$$

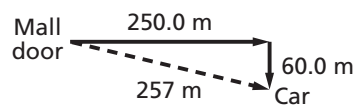

3. A hiker walks 4.5 km in one direction, then makes a 45° turn to the right and walks another 6.4 km. What is the magnitude of her displacement?

$$R^2 = A^2 + B^2 - 2AB \cos \theta$$

$$R = \sqrt{A^2 + B^2 - 2AB \cos \theta}$$

$$= \sqrt{(4.5 \text{ km})^2 + (6.4 \text{ km})^2 - 2(4.5 \text{ km})(6.4 \text{ km})(\cos 135^\circ)}$$

$$= 1.0 \times 10^1 \text{ km}$$

4. An ant is crawling on the sidewalk. At one moment, it is moving south a distance of 5.0 mm. It then turns southwest and crawls 4.0 mm. What is the magnitude of the ant's displacement?

$$R^2 = A^2 + B^2 - 2AB \cos \theta$$

$$R = \sqrt{A^2 + B^2 - 2AB \cos \theta}$$

$$= \sqrt{(5.0 \text{ mm})^2 + (4.0 \text{ mm})^2 - 2(5.0 \text{ mm})(4.0 \text{ mm})(\cos 135^\circ)}$$

$$= 8.3 \text{ mm}$$

Chapter 5 continued

page 125

Solve problems 5–10 algebraically. You may also choose to solve some of them graphically to check your answers.

5. Sudhir walks 0.40 km in a direction 60.0° west of north, then goes 0.50 km due west. What is his displacement?

Identify north and west as the positive directions.

$$d_{1W} = d_1 \sin \theta = (0.40 \text{ km})(\sin 60.0^\circ) = 0.35 \text{ km}$$

$$d_{1N} = d_1 \cos \theta = (0.40 \text{ km})(\cos 60.0^\circ) = 0.20 \text{ km}$$

$$d_{2W} = 0.50 \text{ km} \quad d_{2N} = 0.00 \text{ km}$$

$$R_W = d_{1W} + d_{2W} = 0.35 \text{ km} + 0.50 \text{ km} = 0.85 \text{ km}$$

$$R_N = d_{1N} + d_{2N} = 0.20 \text{ km} + 0.00 \text{ km} = 0.20 \text{ km}$$

$$R = \sqrt{R_W^2 + R_N^2}$$

$$= \sqrt{(0.85 \text{ km})^2 + (0.20 \text{ km})^2}$$

$$= 0.87 \text{ km}$$

$$\theta = \tan^{-1}\left(\frac{R_W}{R_N}\right)$$

$$= \tan^{-1}\left(\frac{0.85 \text{ km}}{0.20 \text{ km}}\right)$$

$$= 77^\circ$$

$R = 0.87 \text{ km}$ at 77° west of north

6. Afua and Chrissy are going to sleep overnight in their tree house and are using some ropes to pull up a box containing their pillows and blankets, which have a total mass of 3.20 kg. The girls stand on different branches, as shown in **Figure 5-6**, and pull at the angles and with the forces indicated. Find the x - and y -components of the net force on the box. *Hint: Draw a free-body diagram so that you do not leave out a force.*

Identify up and right as positive.

$$F_{A \text{ on box},x} = F_{A \text{ on box}} \cos \theta_A$$

$$= (20.4 \text{ N})(\cos 120^\circ)$$

$$= -10.2 \text{ N}$$

$$F_{A \text{ on box},y} = F_{A \text{ on box}} \sin \theta_A$$

$$= (20.4 \text{ N})(\sin 120^\circ)$$

$$= 17.7 \text{ N}$$

$$F_{C \text{ on box},x} = F_{C \text{ on box}} \cos \theta_C$$

$$= (17.7 \text{ N})(\cos 55^\circ)$$

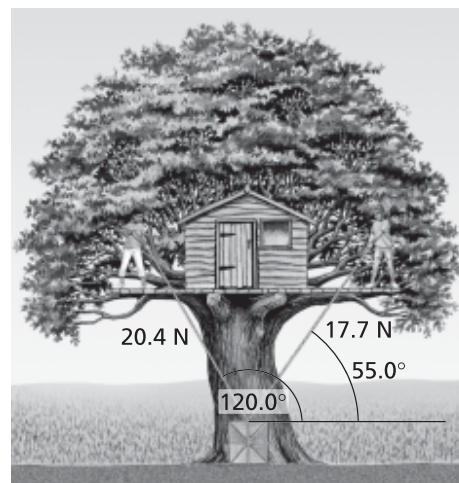

■ Figure 5-6

Chapter 5 continued

$$\begin{aligned}
 &= 10.2 \text{ N} \\
 F_{\text{C on box},y} &= F_{\text{C on box}} \sin \theta_A \\
 &= (17.7 \text{ N})(\sin 55^\circ) \\
 &= 14.5 \text{ N}
 \end{aligned}$$

$$F_{g,x} = 0.0 \text{ N}$$

$$\begin{aligned}
 F_{g,y} &= -mg \\
 &= -(3.20 \text{ kg})(9.80 \text{ m/s}^2) \\
 &= -31.4 \text{ N}
 \end{aligned}$$

$$\begin{aligned}
 F_{\text{net on box},x} &= F_{\text{A on box},x} + \\
 &\quad F_{\text{C on box},x} + F_{g,x} \\
 &= -10.2 \text{ N} + 10.2 \text{ N} + 0.0 \text{ N} \\
 &= 0.0 \text{ N}
 \end{aligned}$$

$$\begin{aligned}
 F_{\text{net on box},y} &= F_{\text{A on box},y} + \\
 &\quad F_{\text{C on box},y} + F_{g,y} \\
 &= 17.7 \text{ N} + 14.5 \text{ N} - 31.4 \text{ N} \\
 &= 0.8 \text{ N}
 \end{aligned}$$

The net force is 0.8 N in the upward direction.

7. You first walk 8.0 km north from home, then walk east until your displacement from home is 10.0 km. How far east did you walk?

The resultant is 10.0 km. Using the Pythagorean Theorem, the distance east is

$$\begin{aligned}
 R^2 &= A^2 + B^2, \text{ so} \\
 B &= \sqrt{R^2 - A^2} \\
 &= \sqrt{(10.0 \text{ km})^2 - (8.0 \text{ km})^2} \\
 &= 6.0 \text{ km}
 \end{aligned}$$

8. A child's swing is held up by two ropes tied to a tree branch that hangs 13.0° from the vertical. If the tension in each rope is 2.28 N, what is the combined force (magnitude and direction) of the two ropes on the swing?

The force will be straight up. Because the angles are equal, the horizontal forces will be equal and opposite and cancel out. The magnitude of this vertical force is

$$\begin{aligned}
 F_{\text{combined}} &= F_{\text{rope1 on swing}} \cos \theta + \\
 &\quad F_{\text{rope2 on swing}} \cos \theta \\
 &= 2F_{\text{rope2 on swing}} \cos \theta \\
 &= (2)(2.28 \text{ N})(\cos 13.0^\circ) \\
 &= 4.44 \text{ N upward}
 \end{aligned}$$

9. Could a vector ever be shorter than one of its components? Equal in length to one of its components? Explain.

It could never be shorter than one of its components, but if it lies along either the x - or y -axis, then one of its components equals its length.

10. In a coordinate system in which the x -axis is east, for what range of angles is the x -component positive? For what range is it negative?

The x -component is positive for angles less than 90° and for angles greater than 270° . It's negative for angles greater than 90° but less than 270° .

Section Review

5.1 Vectors pages 119–125

page 125

11. **Distance v. Displacement** Is the distance that you walk equal to the magnitude of your displacement? Give an example that supports your conclusion.

Not necessarily. For example, you could walk around the block (one km per side). Your displacement would be zero, but the distance that you walk would be 4 kilometers.

12. **Vector Difference** Subtract vector \mathbf{K} from vector \mathbf{L} , shown in **Figure 5-7**.

Chapter 5 continued

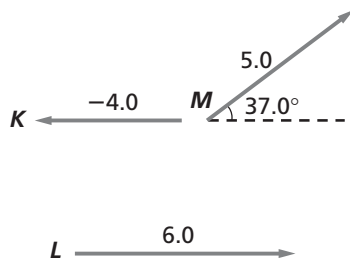

■ Figure 5-7

$$6.0 - (-4.0) = 10.0 \text{ to the right}$$

13. **Components** Find the components of vector M , shown in Figure 5-7.

$$\begin{aligned} M_x &= m \cos \theta \\ &= (5.0)(\cos 37.0^\circ) \\ &= 4.0 \text{ to the right} \end{aligned}$$

$$\begin{aligned} M_y &= m \sin \theta \\ &= (5.0)(\sin 37.0^\circ) \\ &= 3.0 \text{ upward} \end{aligned}$$

14. **Vector Sum** Find the sum of the three vectors shown in Figure 5-7.

$$\begin{aligned} R_x &= K_x + L_x + M_x \\ &= -4.0 + 6.0 + 4.0 \\ &= 6.0 \end{aligned}$$

$$\begin{aligned} R_y &= K_y + L_y + M_y \\ &= 0.0 + 0.0 + 3.0 \\ &= 3.0 \end{aligned}$$

$$\begin{aligned} R &= \sqrt{R_x^2 + R_y^2} \\ &= \sqrt{6.0^2 + 3.0^2} \\ &= 6.7 \end{aligned}$$

$$\begin{aligned} \theta &= \tan^{-1}\left(\frac{R_y}{R_x}\right) \\ &= \tan^{-1}\left(\frac{3}{6}\right) \\ &= 27^\circ \end{aligned}$$

$$R = 6.7 \text{ at } 27^\circ$$

15. **Commutative Operations** The order in which vectors are added does not matter. Mathematicians say that vector addition is commutative. Which ordinary arithmetic operations are commutative? Which are not?

Addition and multiplication are commutative. Subtraction and division are not.

16. **Critical Thinking** A box is moved through one displacement and then through a second displacement. The magnitudes of the two displacements are unequal. Could the displacements have directions such that the resultant displacement is zero? Suppose the box was moved through three displacements of unequal magnitude. Could the resultant displacement be zero? Support your conclusion with a diagram.

No, but if there are three displacements, the sum can be zero if the three vectors form a triangle when they are placed tip-to-tail. Also, the sum of three displacements can be zero without forming a triangle if the sum of two displacements in one direction equals the third in the opposite direction.



Practice Problems

5.2 Friction pages 126–130

page 128

17. A girl exerts a 36-N horizontal force as she pulls a 52-N sled across a cement sidewalk at constant speed. What is the coefficient of kinetic friction between the sidewalk and the metal sled runners? Ignore air resistance.

$$F_N = mg = 52 \text{ N}$$

Since the speed is constant, the friction force equals the force exerted by the girl, 36 N.

$$F_f = \mu_k F_N$$

$$\begin{aligned} \text{so } \mu_k &= \frac{F_f}{F_N} \\ &= \frac{36 \text{ N}}{52 \text{ N}} \\ &= 0.69 \end{aligned}$$

18. You need to move a 105-kg sofa to a different location in the room. It takes a force of 102 N to start it moving. What is the coefficient of static friction between the sofa and the carpet?

Chapter 5 continued

$$\begin{aligned}
 F_f &= \mu_s F_N \\
 \mu_s &= \frac{F_f}{F_N} \\
 &= \frac{F_f}{mg} \\
 &= \frac{102 \text{ N}}{(105 \text{ kg})(9.80 \text{ m/s}^2)} \\
 &= 0.0991
 \end{aligned}$$

19. Mr. Ames is dragging a box full of books from his office to his car. The box and books together have a combined weight of 134 N. If the coefficient of static friction between the pavement and the box is 0.55, how hard must Mr. Ames push the box in order to start it moving?

$$\begin{aligned}
 F_{\text{Ames on box}} &= F_{\text{friction}} \\
 &= \mu_s F_N \\
 &= \mu_s mg \\
 &= (0.55)(134 \text{ N}) \\
 &= 74 \text{ N}
 \end{aligned}$$

20. Suppose that the sled in problem 17 is resting on packed snow. The coefficient of kinetic friction is now only 0.12. If a person weighing 650 N sits on the sled, what force is needed to pull the sled across the snow at constant speed?

At constant speed, applied force equals friction force, so

$$\begin{aligned}
 F_f &= \mu_k F_N \\
 &= (0.12)(52 \text{ N} + 650 \text{ N}) \\
 &= 84 \text{ N}
 \end{aligned}$$

21. Suppose that a particular machine in a factory has two steel pieces that must rub against each other at a constant speed. Before either piece of steel has been treated to reduce friction, the force necessary to get them to perform properly is 5.8 N. After the pieces have been treated with oil, what will be the required force?

$$\begin{aligned}
 F_{f, \text{ before}} &= \mu_{k, \text{ before}} F_N \\
 \text{so } F_N &= \frac{F_{f, \text{ before}}}{\mu_{k, \text{ before}}}
 \end{aligned}$$

$$\begin{aligned}
 &= \frac{5.8 \text{ N}}{0.58} \\
 &= 1.0 \times 10^1 \text{ N}
 \end{aligned}$$

$$\begin{aligned}
 F_{f, \text{ after}} &= \mu_{k, \text{ after}} F_N \\
 &= (0.06)(1.0 \times 10^1 \text{ N}) \\
 &= 0.6 \text{ N}
 \end{aligned}$$

page 130

22. A 1.4-kg block slides across a rough surface such that it slows down with an acceleration of 1.25 m/s^2 . What is the coefficient of kinetic friction between the block and the surface?

$$\begin{aligned}
 F_{\text{net}} &= \mu_k F_N \\
 ma &= \mu_k mg \\
 \mu_k &= \frac{a}{g} \\
 &= \frac{1.25 \text{ m/s}^2}{9.80 \text{ m/s}^2} \\
 &= 0.128
 \end{aligned}$$

23. You help your mom move a 41-kg bookcase to a different place in the living room. If you push with a force of 65 N and the bookcase accelerates at 0.12 m/s^2 , what is the coefficient of kinetic friction between the bookcase and the carpet?

$$\begin{aligned}
 F_{\text{net}} &= F - \mu_k F_N = F - \mu_k mg = ma \\
 \mu_k &= \frac{F - ma}{mg} \\
 &= \frac{65 \text{ N} - (41 \text{ kg})(0.12 \text{ m/s}^2)}{(41 \text{ kg})(9.80 \text{ m/s}^2)} \\
 &= 0.15
 \end{aligned}$$

24. A shuffleboard disk is accelerated to a speed of 5.8 m/s and released. If the coefficient of kinetic friction between the disk and the concrete court is 0.31, how far does the disk go before it comes to a stop? The courts are 15.8 m long.

Identify the direction of the disk's motion as positive. Find the acceleration of the disk due to the force of friction.

$$\begin{aligned}
 F_{\text{net}} &= -\mu_k F_N = -\mu_k mg = ma \\
 a &= -\mu_k g
 \end{aligned}$$

Chapter 5 continued

Then use the equation $v_f^2 = v_i^2 + 2a(d_f - d_i)$ to find the distance.

Let $d_i = 0$ and solve for d_f .

$$\begin{aligned} d_f &= \frac{v_f^2 - v_i^2}{2a} \\ &= \frac{v_f^2 - v_i^2}{(2)(-\mu_k g)} \\ &= \frac{(0.0 \text{ m/s})^2 - (5.8 \text{ m/s})^2}{(2)(-0.31)(9.80 \text{ m/s}^2)} \\ &= 5.5 \text{ m} \end{aligned}$$

25. Consider the force pushing the box in Example Problem 4. How long would it take for the velocity of the box to double to 2.0 m/s?

The initial velocity is 1.0 m/s, the final velocity is 2.0 m/s, and the acceleration is 2.0 m/s², so

$$a = \frac{v_f - v_i}{t_f - t_i}; \text{ let } t_i = 0 \text{ and solve for } t_f.$$

$$\begin{aligned} t_f &= \frac{v_f - v_i}{a} \\ &= \frac{2.0 \text{ m/s} - 1.0 \text{ m/s}}{2.0 \text{ m/s}^2} \\ &= 0.50 \text{ s} \end{aligned}$$

26. Ke Min is driving along on a rainy night at 23 m/s when he sees a tree branch lying across the road and slams on the brakes when the branch is 60.0 m in front of him. If the coefficient of kinetic friction between the car's locked tires and the road is 0.41, will the car stop before hitting the branch? The car has a mass of 2400 kg.

Choose positive direction as direction of car's movement.

$$F_{\text{net}} = -\mu_k F_N = -\mu_k mg = ma$$

$$a = -\mu_k g$$

Then use the equation $v_f^2 = v_i^2 + 2a(d_f - d_i)$ to find the distance.

Let $d_i = 0$ and solve for d_f .

$$\begin{aligned} d_f &= \frac{v_f^2 - v_i^2}{2a} \\ &= \frac{v_f^2 - v_i^2}{(2)(-\mu_k g)} \end{aligned}$$

$$= \frac{(0.0 \text{ m/s}) - (23 \text{ m/s})^2}{(2)(-0.41)(9.80 \text{ m/s}^2)}$$

= 66 m, so he hits the branch before he can stop.

Section Review

5.2 Friction pages 126–130

page 130

27. **Friction** In this section, you learned about static and kinetic friction. How are these two types of friction similar? What are the differences between static and kinetic friction?

They are similar in that they both act in a direction opposite to the motion (or intended motion) and they both result from two surfaces rubbing against each other. Both are dependent on the normal force between these two surfaces. Static friction applies when there is no relative motion between the two surfaces. Kinetic friction is the type of friction when there is relative motion. The coefficient of static friction between two surfaces is greater than the coefficient of kinetic friction between those same two surfaces.

28. **Friction** At a wedding reception, you notice a small boy who looks like his mass is about 25 kg, running part way across the dance floor, then sliding on his knees until he stops. If the kinetic coefficient of friction between the boy's pants and the floor is 0.15, what is the frictional force acting on him as he slides?

$$\begin{aligned} F_{\text{friction}} &= \mu_k F_N \\ &= \mu_k mg \\ &= (0.15)(25 \text{ kg})(9.80 \text{ m/s}^2) \\ &= 37 \text{ N} \end{aligned}$$

29. **Velocity** Derek is playing cards with his friends, and it is his turn to deal. A card has a mass of 2.3 g, and it slides 0.35 m along the table before it stops. If the coefficient of kinetic friction between the card and the table is 0.24, what was the initial speed of the card as it left Derek's hand?

Chapter 5 continued

Identify the direction of the card's movement as positive

$$F_{\text{net}} = -\mu_k F_N = -\mu_k mg = ma$$

$$a = -\mu_k g$$

$$v_f = d_i = 0 \text{ so}$$

$$v_i = \sqrt{-2ad_f}$$

$$= \sqrt{-2(-\mu_k g)d_f}$$

$$= \sqrt{-2(-0.24)(9.80 \text{ m/s}^2)(0.35 \text{ m})}$$

$$= 1.3 \text{ m/s}$$

- 30. Force** The coefficient of static friction between a 40.0-kg picnic table and the ground below it is 0.43 m. What is the greatest horizontal force that could be exerted on the table while it remains stationary?

$$F_f = \mu_s F_N$$

$$= \mu_s mg$$

$$= (0.43)(40.0 \text{ kg})(9.80 \text{ m/s}^2)$$

$$= 1.7 \times 10^2 \text{ N}$$

- 31. Acceleration** Ryan is moving to a new apartment and puts a dresser in the back of his pickup truck. When the truck accelerates forward, what force accelerates the dresser? Under what circumstances could the dresser slide? In which direction?

Friction between the dresser and the truck accelerates the dresser forward. The dresser will slide backward if the force accelerating it is greater than $\mu_s mg$.

- 32. Critical Thinking** You push a 13-kg table in the cafeteria with a horizontal force of 20 N, but it does not move. You then push it with a horizontal force of 25 N, and it accelerates at 0.26 m/s^2 . What, if anything, can you conclude about the coefficients of static and kinetic friction?

From the sliding portion of your experiment you can determine that the coefficient of kinetic friction between the table and the floor is

$$F_f = F_{\text{on table}} - F_2$$

$$\mu_k F_N = F_{\text{on table}} - ma$$

$$\mu_k = \frac{F_{\text{on table}} - ma}{mg}$$

$$= \frac{25 \text{ N} - (13 \text{ kg})(0.26 \text{ m/s}^2)}{(13 \text{ kg})(9.80 \text{ m/s}^2)}$$

$$= 0.17$$

All you can conclude about the coefficient of static friction is that it is between

$$\mu_s = \frac{F_{\text{on table}}}{mg}$$

$$= \frac{20 \text{ N}}{(13 \text{ kg})(9.80 \text{ m/s}^2)}$$

$$= 0.16$$

$$\text{and } \mu_s = \frac{F_{\text{on table}}}{mg}$$

$$= \frac{25 \text{ N}}{(13 \text{ kg})(9.80 \text{ m/s}^2)}$$

$$= 0.20$$

Practice Problems

5.3 Force and Motion in Two Dimensions pages 131–135

page 133

- 33.** An ant climbs at a steady speed up the side of its anthill, which is inclined 30.0° from the vertical. Sketch a free-body diagram for the ant.

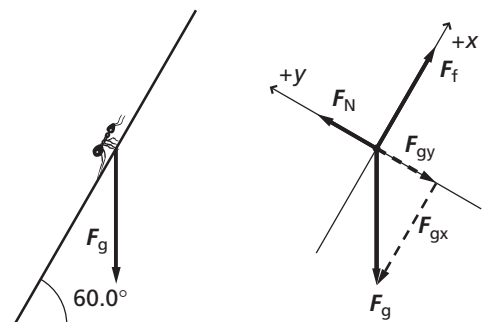

Chapter 5 continued

- 34.** Scott and Becca are moving a folding table out of the sunlight. A cup of lemonade, with a mass of 0.44 kg, is on the table. Scott lifts his end of the table before Becca does, and as a result, the table makes an angle of 15.0° with the horizontal. Find the components of the cup's weight that are parallel and perpendicular to the plane of the table.

$$F_{g, \text{parallel}} = F_g \sin \theta$$

$$= (0.44 \text{ kg})(9.80 \text{ m/s}^2)(\sin 15.0^\circ)$$

$$= 1.1 \text{ N}$$

$$F_{g, \text{perpendicular}} = F_g \cos \theta$$

$$= (0.44 \text{ kg})(9.80 \text{ m/s}^2)(\cos 15.0^\circ)$$

$$= 4.2 \text{ N}$$

- 35.** Kohana, who has a mass of 50.0 kg, is at the dentist's office having her teeth cleaned, as shown in **Figure 5-14**. If the component of her weight perpendicular to the plane of the seat of the chair is 449 N, at what angle is the chair tilted?

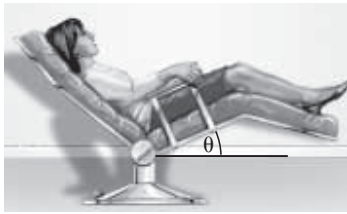

■ **Figure 5-14**

$$F_{g, \text{perpendicular}} = F_g \cos \theta = mg \cos \theta$$

$$\theta = \cos^{-1}\left(\frac{F_{g, \text{perpendicular}}}{mg}\right)$$

$$= \cos^{-1}\left(\frac{449 \text{ N}}{(50.0 \text{ kg})(9.80 \text{ m/s}^2)}\right)$$

$$= 23.6^\circ$$

- 36.** Fernando, who has a mass of 43.0 kg, slides down the banister at his grandparents' house. If the banister makes an angle of 35.0° with the horizontal, what is the normal force between Fernando and the banister?

$$F_N = mg \cos \theta$$

$$= (43.0 \text{ kg})(9.80 \text{ m/s}^2)(\cos 35.0^\circ)$$

$$= 345 \text{ N}$$

- 37.** A suitcase is on an inclined plane. At what angle, relative to the vertical, will the component of the suitcase's weight parallel to the plane be equal to half the perpendicular component of its weight?

$$F_{g, \text{parallel}} = F_g \sin \theta, \text{ when the angle is with respect to the horizontal}$$

$$F_{g, \text{perpendicular}} = F_g \cos \theta, \text{ when the angle is with respect to the horizontal}$$

$$F_{g, \text{perpendicular}} = 2F_{g, \text{parallel}}$$

$$2 = \frac{F_{g, \text{perpendicular}}}{F_{g, \text{parallel}}}$$

$$= \frac{F_g \cos \theta}{F_g \sin \theta}$$

$$= \frac{1}{\tan \theta}$$

$$\theta = \tan^{-1}\left(\frac{1}{2}\right)$$

$$= 26.6^\circ \text{ relative to the horizontal, or } 63.4^\circ \text{ relative to the vertical}$$

page 135

- 38.** Consider the crate on the incline in Example Problem 5.

- a. Calculate the magnitude of the acceleration.

$$a = \frac{F}{m}$$

$$= \frac{F_g \sin \theta}{m}$$

$$= \frac{mg \sin \theta}{m}$$

$$= g \sin \theta$$

$$= (9.80 \text{ m/s}^2)(\sin 30.0^\circ)$$

$$= 4.90 \text{ m/s}^2$$

- b. After 4.00 s, how fast will the crate be moving?

$$a = \frac{v_f - v_i}{t_f - t_i}; \text{ let } v_i = t_i = 0.$$

Solve for v_f .

$$v_f = at_f$$

$$= (4.90 \text{ m/s}^2)(4.00 \text{ s})$$

$$= 19.6 \text{ m/s}$$

Chapter 5 continued

39. If the skier in Example Problem 6 were on a 31° downhill slope, what would be the magnitude of the acceleration?

$$\begin{aligned} \text{Since } a &= g(\sin \theta - \mu \cos \theta), \\ a &= (9.80 \text{ m/s}^2)(\sin 31^\circ - (0.15)(\cos 31^\circ)) \\ &= 3.8 \text{ m/s}^2 \end{aligned}$$

40. Stacie, who has a mass of 45 kg, starts down a slide that is inclined at an angle of 45° with the horizontal. If the coefficient of kinetic friction between Stacie's shorts and the slide is 0.25, what is her acceleration?

$$\begin{aligned} F_{\text{Stacie's weight parallel with slide}} - F_f &= ma \\ a &= \frac{F_{\text{Stacie's weight parallel with slide}} - F_f}{m} \\ &= \frac{mg \sin \theta - \mu_k F_N}{m} \\ &= \frac{mg \sin \theta - \mu_k mg \cos \theta}{m} \\ &= g(\sin \theta - \mu_k \cos \theta) \\ &= (9.80 \text{ m/s}^2)[\sin 45^\circ - (0.25)(\cos 45^\circ)] \\ &= 5.2 \text{ m/s}^2 \end{aligned}$$

41. After the skier on the 37° hill in Example Problem 6 had been moving for 5.0 s, the friction of the snow suddenly increased and made the net force on the skier zero. What is the new coefficient of friction?

$$\begin{aligned} a &= g(\sin \theta - \mu_k \cos \theta) \\ a &= g \sin \theta - g\mu_k \cos \theta \\ \text{If } a &= 0, \\ 0 &= g \sin \theta - g\mu_k \cos \theta \\ \mu_k \cos \theta &= \sin \theta \\ \mu_k &= \frac{\sin \theta}{\cos \theta} \\ \mu_k &= \frac{\sin 37^\circ}{\cos 37^\circ} \\ &= 0.75 \end{aligned}$$

Section Review

5.3 Force and Motion in Two Dimensions pages 131–135

page 135

42. **Forces** One way to get a car unstuck is to tie one end of a strong rope to the car and the other end to a tree, then push the rope at its midpoint at right angles to the rope. Draw a free-body diagram and explain why even a small force on the rope can exert a large force on the car.

The vectors shown in the free body diagram indicate that even a small force perpendicular to the rope can increase the tension in the rope enough to overcome the friction force. Since $F = 2T \sin \theta$ (where θ is the angle between the rope's original position and its displaced position),

$$T = \frac{F}{2 \sin \theta}$$

For smaller values of θ , the tension, T , will increase greatly.

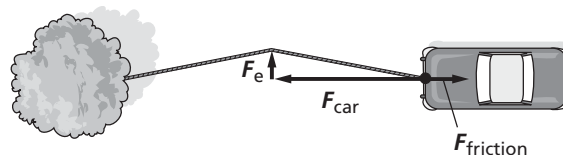

Chapter 5 continued

43. **Mass** A large scoreboard is suspended from the ceiling of a sports arena by 10 strong cables. Six of the cables make an angle of 8.0° with the vertical while the other four make an angle of 10.0° . If the tension in each cable is 1300.0 N, what is the scoreboard's mass?

$$F_{\text{net},y} = ma_y = 0$$

$$F_{\text{net},y} = F_{\text{cables on board}} - F_g$$

$$= 6F_{\text{cable}} \cos \theta_6 + 4F_{\text{cable}} \cos \theta_4 - mg = 0$$

$$m = \frac{6F_{\text{cable}} \cos \theta_6 + 4F_{\text{cable}} \cos \theta_4}{g}$$

$$= \frac{6(1300.0 \text{ N})(\cos 8.0^\circ) + 4(1300.0 \text{ N})(\cos 10.0^\circ)}{9.80 \text{ m/s}^2}$$

$$= 1.31 \times 10^3 \text{ kg}$$

موقع
المنهج البحرينية
almanahj.com/bn

44. **Acceleration** A 63-kg water skier is pulled up a 14.0° incline by a rope parallel to the incline with a tension of 512 N. The coefficient of kinetic friction is 0.27. What are the magnitude and direction of the skier's acceleration?

$$F_N = mg \cos \theta$$

$$F_{\text{rope on skier}} - F_g - F_f = ma$$

$$F_{\text{rope on skier}} - mg \sin \theta - \mu_k mg \cos \theta = ma$$

$$a = \frac{F_{\text{rope on skier}} - mg \sin \theta - \mu_k mg \cos \theta}{m}$$

$$= \frac{512 \text{ N} - (63 \text{ kg})(9.80 \text{ m/s}^2)(\sin 14.0^\circ) - (0.27)(63 \text{ kg})(9.80 \text{ m/s}^2)(\cos 14.0^\circ)}{63 \text{ kg}}$$

$$= 3.2 \text{ m/s}^2, \text{ up the incline}$$

45. **Equilibrium** You are hanging a painting using two lengths of wire. The wires will break if the force is too great. Should you hang the painting as shown in **Figures 5-15a** or **5-15b**? Explain.

Figure 5-15b; $F_T = \frac{F_g}{2 \sin \theta}$, so F_T gets smaller as θ gets larger, and θ is larger in 5-15b.



■ Figure 5-15a



■ Figure 5-15b

46. **Critical Thinking** Can the coefficient of friction ever have a value such that a skier would be able to slide uphill at a constant velocity? Explain why or why not. Assume there are no other forces acting on the skier.

No, because both the frictional force opposing the motion of the skier and the component of Earth's gravity parallel to the slope point downhill, not uphill.

Chapter Assessment

Concept Mapping

page 140

47. Complete the concept map below by labeling the circles with *sine*, *cosine*, or *tangent* to indicate whether each function is positive or negative in each quadrant.

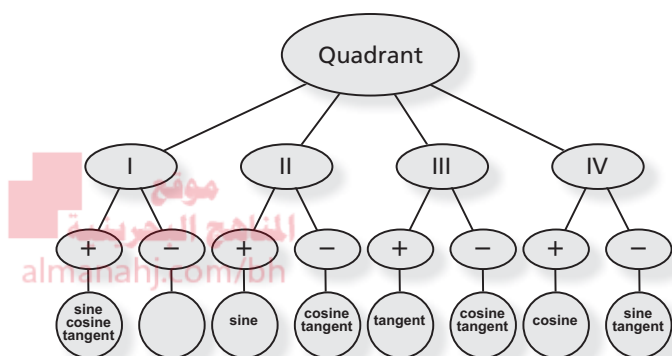

Mastering Concepts

page 140

48. Describe how you would add two vectors graphically. (5.1)
Make scale drawings of arrows representing the vector quantities. Place the arrows for the quantities to be added tip-to-tail. Draw an arrow from the tail of the first to the tip of the last. Measure the length of that arrow and find its direction.
49. Which of the following actions is permissible when you graphically add one vector to another: moving the vector, rotating the vector, or changing the vector's length? (5.1)
allowed: moving the vector without changing length or direction
50. In your own words, write a clear definition of the resultant of two or more vectors. Do not explain how to find it; explain what it represents. (5.1)
The resultant is the vector sum of two or more vectors. It represents the quantity that results from adding the vectors.
51. How is the resultant displacement affected when two displacement vectors are added in a different order? (5.1)
It is not affected.

52. Explain the method that you would use to subtract two vectors graphically. (5.1)
Reverse the direction of the second vector and then add them.
53. Explain the difference between these two symbols: A and \vec{A} . (5.1)
 A is the symbol for the vector quantity. \vec{A} is the signed magnitude (length) of the vector.
54. The Pythagorean theorem usually is written $c^2 = a^2 + b^2$. If this relationship is used in vector addition, what do a , b , and c represent? (5.1)
 a and b represent the lengths of two vectors that are at the right angles to one another. c represents the length of the sum of the two vectors.
55. When using a coordinate system, how is the angle or direction of a vector determined with respect to the axes of the coordinate system? (5.1)
The angle is measured counterclockwise from the x-axis.
56. What is the meaning of a coefficient of friction that is greater than 1.0? How would you measure it? (5.2)
The frictional force is greater than the normal force. You can pull the object along the surface, measuring the force needed to move it at constant speed. Also measure the weight of the object.
57. **Cars** Using the model of friction described in this textbook, would the friction between a tire and the road be increased by a wide rather than a narrow tire? Explain. (5.2)
It would make no difference. Friction does not depend upon surface area.
58. Describe a coordinate system that would be suitable for dealing with a problem in which a ball is thrown up into the air. (5.3)
One axis is vertical, with the positive direction either up or down.

Chapter 5 continued

59. If a coordinate system is set up such that the positive x -axis points in a direction 30° above the horizontal, what should be the angle between the x -axis and the y -axis? What should be the direction of the positive y -axis? (5.3)

The two axes must be at right angles. The positive y -axis points 30° away from the vertical so that it is at right angles to the x -axis.

60. Explain how you would set up a coordinate system for motion on a hill. (5.3)

For motion on a hill, the vertical (y) axis is usually set up perpendicular, or normal, to the surface of the hill.

61. If your textbook is in equilibrium, what can you say about the forces acting on it? (5.3)

The net force acting on the book is zero.

62. Can an object that is in equilibrium be moving? Explain. (5.3)

Yes, Newton's first law permits motion as long as the object's velocity is constant. It cannot accelerate.

63. What is the sum of three vectors that, when placed tip to tail, form a triangle? If these vectors represent forces on an object, what does this imply about the object? (5.3)

The vector sum of forces forming a closed triangle is zero. If these are the only forces acting on the object, the net force on the object is zero and the object is in equilibrium.

64. You are asked to analyze the motion of a book placed on a sloping table. (5.3)

- a. Describe the best coordinate system for analyzing the motion.

Set up the y -axis perpendicular to the surface of the table and the x -axis pointing uphill and parallel to the surface.

- b. How are the components of the weight of the book related to the angle of the table?

One component is parallel to the inclined surface and the other is perpendicular to it.

65. For a book on a sloping table, describe what happens to the component of the weight force parallel to the table and the force of friction on the book as you increase the angle that the table makes with the horizontal. (5.3)

- a. Which components of force(s) increase when the angle increases?

As you increase the angle the table makes with the horizontal, the component of the book's weight force along the table increases.

- b. Which components of force(s) decrease?

When the angle increases, the component of the weight force normal to the table decreases and the friction force decreases.

Applying Concepts

pages 140–141

66. A vector that is 1 cm long represents a displacement of 5 km. How many kilometers are represented by a 3-cm vector drawn to the same scale?

$$(3 \text{ cm})\left(\frac{5 \text{ km}}{1 \text{ cm}}\right) = 15 \text{ km}$$

67. **Mowing the Lawn** If you are pushing a lawn mower across the grass, as shown in **Figure 5-16**, can you increase the horizontal component of the force that you exert on the mower without increasing the magnitude of the force? Explain.

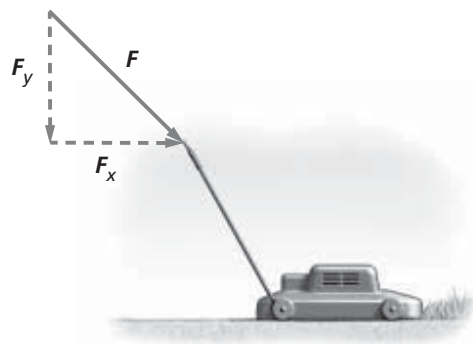

■ Figure 5-16

Chapter 5 continued

Yes, lower the handle to make the angle between the handle and the horizontal smaller.

68. A vector drawn 15 mm long represents a velocity of 30 m/s. How long should you draw a vector to represent a velocity of 20 m/s?

$$(20 \text{ m/s}) \left(\frac{15 \text{ mm}}{30 \text{ m/s}} \right) = 10 \text{ mm}$$

69. What is the largest possible displacement resulting from two displacements with magnitudes 3 m and 4 m? What is the smallest possible resultant? Draw sketches to demonstrate your answers.

The largest is 7 m; the smallest is 1 m.

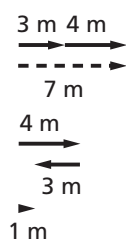

70. How does the resultant displacement change as the angle between two vectors increases from 0° to 180° ?

The resultant increases.

71. A and B are two sides of a right triangle, where $\tan \theta = A/B$.
- Which side of the triangle is longer if $\tan \theta$ is greater than 1.0?
A is longer.
 - Which side is longer if $\tan \theta$ is less than 1.0?
B is longer.
 - What does it mean if $\tan \theta$ is equal to 1.0?
A and B are equal in length.

72. **Traveling by Car** A car has a velocity of 50 km/h in a direction 60° north of east. A coordinate system with the positive x -axis pointing east and a positive y -axis pointing north is chosen. Which component of the velocity vector is larger, x or y ?

The northward component (y) is longer.

73. Under what conditions can the Pythagorean theorem, rather than the law of cosines, be used to find the magnitude of a resultant vector?

The Pythagorean theorem can be used only if the two vectors to be added are at right angles to one another.

74. A problem involves a car moving up a hill, so a coordinate system is chosen with the positive x -axis parallel to the surface of the hill. The problem also involves a stone that is dropped onto the car. Sketch the problem and show the components of the velocity vector of the stone.

One component is in the negative x -direction, the other in the negative y -direction, assuming that the positive direction points upward, perpendicular to the hill.

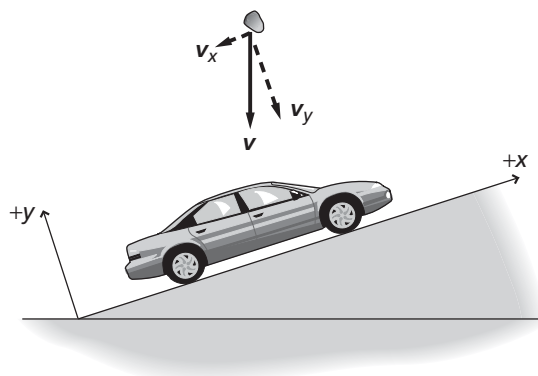

75. **Pulling a Cart** According to legend, a horse learned Newton's laws. When the horse was told to pull a cart, it refused, saying that if it pulled the cart forward, according to Newton's third law, there would be an equal force backwards; thus, there would be balanced forces, and, according to Newton's second law, the cart would not accelerate. How would you reason with this horse?

The equal and opposite forces referred to in Newton's third law are acting on different objects. The horse would pull on the cart, and the cart would pull on the horse. The cart would have an unbalanced net force on it (neglecting friction) and would thus accelerate.

Chapter 5 continued

- 76. Tennis** When stretching a tennis net between two posts, it is relatively easy to pull one end of the net hard enough to remove most of the slack, but you need a winch to take the last bit of slack out of the net to make the top almost completely horizontal. Why is this true?

When stretching the net between the two posts, there is no perpendicular component upward to balance the weight of the net. All the force exerted on the net is horizontal. Stretching the net to remove the last bit of slack requires great force in order to reduce the flexibility of the net and to increase the internal forces that hold it together.

- 77.** The weight of a book on an inclined plane can be resolved into two vector components, one along the plane, and the other perpendicular to it.
- At what angle are the components equal?
 45°
 - At what angle is the parallel component equal to zero?
 0°
 - At what angle is the parallel component equal to the weight?
 90°

- 78. TV Towers** The transmitting tower of a TV station is held upright by guy wires that extend from the top of the tower to the ground. The force along the guy wires can be resolved into two perpendicular components. Which one is larger?

The component perpendicular to the ground is larger if the angle between the guy wire and horizontal is greater than 45° .

Mastering Problems

5.1 Vectors

pages 141–142

Level 1

- 79. Cars** A car moves 65 km due east, then 45 km due west. What is its total displacement?

$$65 \text{ km} + (-45 \text{ km}) = 2.0 \times 10^1 \text{ km}$$

$$\Delta d = 2.0 \times 10^1 \text{ km, east}$$

- 80.** Find the horizontal and vertical components of the following vectors, as shown in Figure 5-17.

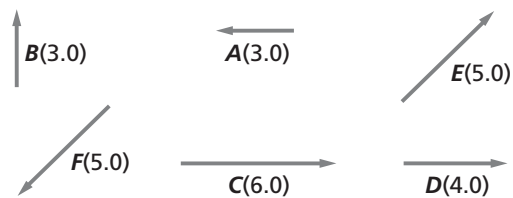

■ Figure 5-17

- a. E**
- $$E_x = E \cos \theta$$
- $$= (5.0)(\cos 45^\circ)$$
- $$= 3.5$$
- $$E_y = E \sin \theta$$
- $$= (5.0)(\sin 45^\circ)$$
- $$= 3.5$$
- b. F**
- $$F_x = F \cos \theta$$
- $$= (5.0)(\cos 225^\circ)$$
- $$= -3.5$$
- $$F_y = F \sin \theta$$
- $$= (5.0)(\sin 225^\circ)$$
- $$= -3.5$$
- c. A**
- $$A_x = A \cos \theta$$
- $$= (3.0)(\cos 180^\circ)$$
- $$= -3.0$$
- $$A_y = A \sin \theta$$
- $$= (3.0)(\sin 180^\circ)$$
- $$= 0.0$$

Chapter 5 continued

81. Graphically find the sum of the following pairs of vectors, whose lengths and directions are shown in Figure 5-17.

a. D and A

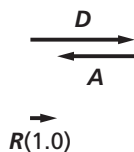

b. C and D

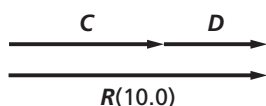

موقع
المنهجية
almanahj.com/bh

c. C and A

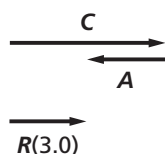

d. E and F

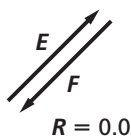

Level 2

82. Graphically add the following sets of vectors, as shown in Figure 5-17.

a. A, C, and D

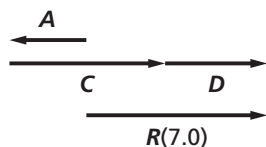

b. A, B, and E

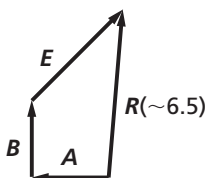

c. B, D, and F

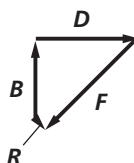

83. You walk 30 m south and 30 m east. Find the magnitude and direction of the resultant displacement both graphically and algebraically.

$$R^2 = A^2 + B^2$$

$$R = \sqrt{(30 \text{ m})^2 + (30 \text{ m})^2}$$

$$= 40 \text{ m}$$

$$\tan \theta = \frac{30 \text{ m}}{30 \text{ m}} = 1$$

$$\theta = 45^\circ$$

$$R = 40 \text{ m}, 45^\circ \text{ east of south}$$

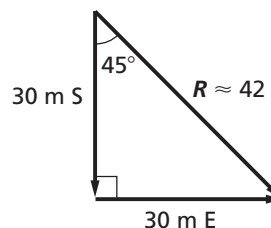

The difference in the answers is due to significant digits being considered in the calculation.

84. Hiking A hiker's trip consists of three segments. Path **A** is 8.0 km long heading 60.0° north of east. Path **B** is 7.0 km long in a direction due east. Path **C** is 4.0 km long heading 315° counterclockwise from east.

a. Graphically add the hiker's displacements in the order **A, B, C**.

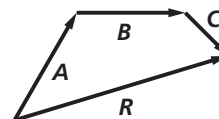

b. Graphically add the hiker's displacements in the order **C, B, A**.

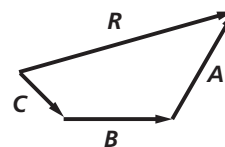

c. What can you conclude about the resulting displacements?

You can add vectors in any order. The result is always the same.

Chapter 5 continued

85. What is the net force acting on the ring in Figure 5-18?

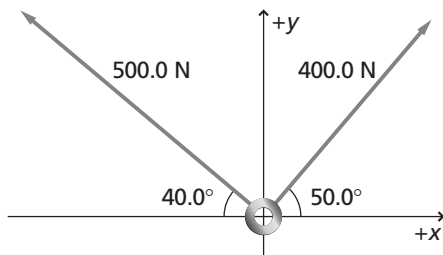

■ Figure 5-18

$$R^2 = A^2 + B^2$$

$$R = \sqrt{A^2 + B^2}$$

$$= \sqrt{(500.0 \text{ N})^2 + (400.0 \text{ N})^2}$$

$$= 640.3 \text{ N}$$

$$\tan \theta = \frac{A}{B}$$

$$\theta = \tan^{-1}\left(\frac{A}{B}\right)$$

$$= \tan^{-1}\left(\frac{500.0}{400.0}\right)$$

$$= 51.34^\circ \text{ from } B$$

The net force is 640.3 N at 51.34°

86. What is the net force acting on the ring in Figure 5-19?

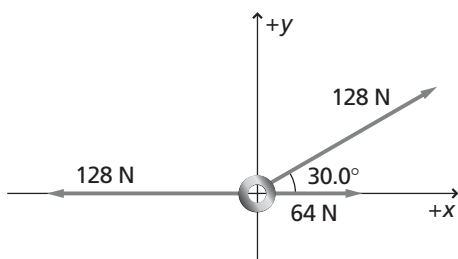

■ Figure 5-19

$$A = -128 \text{ N} + 64 \text{ N}$$

$$= -64 \text{ N}$$

$$A_x = A \cos \theta_A$$

$$= (-64 \text{ N})(\cos 180^\circ)$$

$$= -64 \text{ N}$$

$$A_y = A \sin \theta_A$$

$$= (-64 \text{ N})(\sin 180^\circ)$$

$$= 0 \text{ N}$$

$$B_x = B \cos \theta_B$$

$$= (128 \text{ N})(\cos 30.0^\circ)$$

$$= 111 \text{ N}$$

$$B_y = B \sin \theta_B$$

$$= (128 \text{ N})(\sin 30.0^\circ)$$

$$= 64 \text{ N}$$

$$R_x = A_x + B_x$$

$$= -64 \text{ N} + 111 \text{ N}$$

$$= 47 \text{ N}$$

$$R_y = A_y + B_y$$

$$= 0 \text{ N} + 64 \text{ N}$$

$$= 64 \text{ N}$$

$$R = \sqrt{R_x^2 + R_y^2}$$

$$= \sqrt{(47 \text{ N})^2 + (64 \text{ N})^2}$$

$$= 79 \text{ N}$$

$$\theta = \tan^{-1}\left(\frac{R_y}{R_x}\right)$$

$$= \tan^{-1}\left(\frac{64}{47}\right)$$

$$= 54^\circ$$

Level 3

87. **A Ship at Sea** A ship at sea is due into a port 500.0 km due south in two days. However, a severe storm comes in and blows it 100.0 km due east from its original position. How far is the ship from its destination? In what direction must it travel to reach its destination?

$$R^2 = A^2 + B^2$$

$$R = \sqrt{(100.0 \text{ km})^2 + (500.0 \text{ km})^2}$$

$$= 509.9 \text{ km}$$

$$\theta = \tan^{-1}\left(\frac{R_y}{R_x}\right)$$

$$= \tan^{-1}\left(\frac{500.0}{100.0}\right)$$

$$= 78.69^\circ$$

$R = 509.9 \text{ km}, 78.69^\circ$ south of west

Chapter 5 continued

88. Space Exploration A descent vehicle landing on Mars has a vertical velocity toward the surface of Mars of 5.5 m/s. At the same time, it has a horizontal velocity of 3.5 m/s.

- a. At what speed does the vehicle move along its descent path?

$$R^2 = A^2 + B^2$$

$$R = \sqrt{(5.5 \text{ m/s})^2 + (3.5 \text{ m/s})^2}$$

$$v = R = 6.5 \text{ m/s}$$

- b. At what angle with the vertical is this path?

$$\theta = \tan^{-1}\left(\frac{R_y}{R_x}\right)$$

المنهج البحرينية
almanahj.com

$$= \tan^{-1}\left(\frac{5.5}{3.5}\right)$$

$$= 58^\circ \text{ from horizontal, which is } 32^\circ \text{ from vertical}$$

89. Navigation Alfredo leaves camp and, using a compass, walks 4 km E, then 6 km S, 3 km E, 5 km N, 10 km W, 8 km N, and, finally, 3 km S. At the end of three days, he is lost. By drawing a diagram, compute how far Alfredo is from camp and which direction he should take to get back to camp.

Take north and east to be positive directions. North: $-6 \text{ km} + 5 \text{ km} + 8 \text{ km} - 3 \text{ km} = 4 \text{ km}$. **East:** $4 \text{ km} + 3 \text{ km} - 10 \text{ km} = -3 \text{ km}$. **The hiker is 4 km north and 3 km west of camp. To return to camp, the hiker must go 3 km east and 4 km south.**

$$R^2 = A^2 + B^2$$

$$R = \sqrt{(3 \text{ km})^2 + (4 \text{ km})^2}$$

$$= 5 \text{ km}$$

$$\theta = \tan^{-1}\left(\frac{R_y}{R_x}\right)$$

$$= \tan^{-1}\left(\frac{4 \text{ km}}{3 \text{ km}}\right)$$

$$= 53^\circ$$

$$R = 5 \text{ km}, 53^\circ \text{ south of east}$$

5.2 Friction

page 142

Level 1

90. If you use a horizontal force of 30.0 N to slide a 12.0-kg wooden crate across a floor at a constant velocity, what is the coefficient of kinetic friction between the crate and the floor?

$$F_f = \mu_k F_N = \mu_k mg = F_{\text{horizontal}}$$

$$\mu_k = \frac{F_{\text{horizontal}}}{mg}$$

$$= \frac{30.0 \text{ N}}{(12.0 \text{ kg})(9.80 \text{ m/s}^2)}$$

$$= 0.255$$

91. A 225-kg crate is pushed horizontally with a force of 710 N. If the coefficient of friction is 0.20, calculate the acceleration of the crate.

$$ma = F_{\text{net}} = F_{\text{appl}} - F_f$$

$$\text{where } F_f = \mu_k F_N = \mu_k mg$$

Therefore

$$a = \frac{F_{\text{appl}} - \mu_k mg}{m}$$

$$= \frac{710 \text{ N} - (0.20)(225 \text{ kg})(9.80 \text{ m/s}^2)}{225 \text{ kg}}$$

$$= 1.2 \text{ m/s}^2$$

Level 2

92. A force of 40.0 N accelerates a 5.0-kg block at 6.0 m/s^2 along a horizontal surface.

- a. How large is the frictional force?

$$ma = F_{\text{net}} = F_{\text{appl}} - F_f$$

$$\text{so } F_f = F_{\text{appl}} - ma$$

$$= 40.0 \text{ N} - (5.0 \text{ kg})(6.0 \text{ m/s}^2)$$

$$= 1.0 \times 10^1 \text{ N}$$

- b. What is the coefficient of friction?

$$F_f = \mu_k F_N = \mu_k mg$$

$$\text{so } \mu_k = \frac{F_f}{mg}$$

$$= \frac{1.0 \times 10^1 \text{ N}}{(5.0 \text{ kg})(9.80 \text{ m/s}^2)}$$

$$= 0.20$$

Chapter 5 continued

- 93. Moving Appliances** Your family just had a new refrigerator delivered. The delivery man has left and you realize that the refrigerator is not quite in the right position, so you plan to move it several centimeters. If the refrigerator has a mass of 180 kg, the coefficient of kinetic friction between the bottom of the refrigerator and the floor is 0.13, and the static coefficient of friction between these same surfaces is 0.21, how hard do you have to push horizontally to get the refrigerator to start moving?

$$\begin{aligned}
 F_{\text{on fridge}} &= F_{\text{friction}} \\
 &= \mu_s F_N \\
 &= \mu_s mg \\
 &= (0.21)(180 \text{ kg})(9.80 \text{ m/s}^2) \\
 &= 370 \text{ N}
 \end{aligned}$$

Level 3

- 94. Stopping at a Red Light** You are driving a 2500.0-kg car at a constant speed of 14.0 m/s along a wet, but straight, level road. As you approach an intersection, the traffic light turns red. You slam on the brakes. The car's wheels lock, the tires begin skidding, and the car slides to a halt in a distance of 25.0 m. What is the coefficient of kinetic friction between your tires and the wet road?

$$\begin{aligned}
 F_f &= \mu_k F_N = ma \\
 -\mu_k mg &= \frac{m(v_f^2 - v_i^2)}{2\Delta d} \text{ where } v_f = 0
 \end{aligned}$$

(The minus sign indicates the force is acting opposite to the direction of motion.)

$$\begin{aligned}
 \mu_k &= \frac{v_i^2}{2dg} \\
 &= \frac{(14.0 \text{ m/s})^2}{2(25.0 \text{ m})(9.80 \text{ m/s}^2)} \\
 &= 0.400
 \end{aligned}$$

5.3 Force and Motion in Two Dimensions pages 142–143

Level 1

- 95.** An object in equilibrium has three forces exerted on it. A 33.0-N force acts at 90.0° from the x -axis and a 44.0-N force acts at 60.0° from the x -axis. What are the magnitude and direction of the third force?

First, find the magnitude of the sum of these two forces. The equilibrant will have the same magnitude but opposite direction.

$$F_1 = 33.0 \text{ N}, 90.0^\circ$$

$$F_2 = 44.0 \text{ N}, 60.0^\circ$$

$$F_3 = ?$$

$$\begin{aligned}
 F_{1x} &= F_1 \cos \theta_1 \\
 &= (33.0 \text{ N})(\cos 90.0^\circ) \\
 &= 0.0 \text{ N}
 \end{aligned}$$

$$\begin{aligned}
 F_{1y} &= F_1 \sin \theta_1 \\
 &= (33.0 \text{ N})(\sin 90.0^\circ) \\
 &= 33.0 \text{ N}
 \end{aligned}$$

$$\begin{aligned}
 F_{2x} &= F_2 \cos \theta_2 \\
 &= (44.0 \text{ N})(\cos 60.0^\circ) \\
 &= 22.0 \text{ N}
 \end{aligned}$$

$$\begin{aligned}
 F_{2y} &= F_2 \sin \theta_2 \\
 &= (44.0 \text{ N})(\sin 60.0^\circ) \\
 &= 38.1 \text{ N}
 \end{aligned}$$

$$\begin{aligned}
 F_{3x} &= F_{1x} + F_{2x} \\
 &= 0.0 \text{ N} + 22.0 \text{ N} \\
 &= 22.0 \text{ N}
 \end{aligned}$$

$$\begin{aligned}
 F_{3y} &= F_{1y} + F_{2y} \\
 &= 33.0 \text{ N} + 38.1 \text{ N} \\
 &= 71.1 \text{ N}
 \end{aligned}$$

$$\begin{aligned}
 F_3 &= \sqrt{F_{3x}^2 + F_{3y}^2} \\
 &= \sqrt{(22.0 \text{ N})^2 + (71.1 \text{ N})^2} \\
 &= 74.4 \text{ N}
 \end{aligned}$$

Chapter 5 continued

For equilibrium, the sum of the components must equal zero, so

$$\begin{aligned}\theta &= \tan^{-1}\left(\frac{F_{3y}}{F_{3x}}\right) + 180.0^\circ \\ &= \tan^{-1}\left(\frac{71.1 \text{ N}}{22.0 \text{ N}}\right) + 180.0^\circ \\ &= 253^\circ \\ F_3 &= 74.4 \text{ N}, 253^\circ\end{aligned}$$

Level 2

96. Five forces act on an object: (1) 60.0 N at 90.0° , (2) 40.0 N at 0.0° , (3) 80.0 N at 270.0° , (4) 40.0 N at 180.0° , and (5) 50.0 N at 60.0° . What are the magnitude and direction of a sixth force that would produce equilibrium?

Solutions by components

$$F_1 = 60.0 \text{ N}, 90.0^\circ$$

$$F_2 = 40.0 \text{ N}, 0.0^\circ$$

$$F_3 = 80.0 \text{ N}, 270.0^\circ$$

$$F_4 = 40.0 \text{ N}, 180.0^\circ$$

$$F_5 = 50.0 \text{ N}, 60.0^\circ$$

$$F_6 = ?$$

$$\begin{aligned}F_{1x} &= F_1 \cos \theta_1 \\ &= (60.0 \text{ N})(\cos 90.0^\circ) = 0.0 \text{ N}\end{aligned}$$

$$\begin{aligned}F_{1y} &= F_1 \sin \theta_1 = (60.0 \text{ N})(\sin 90.0^\circ) \\ &= 60.0 \text{ N}\end{aligned}$$

$$\begin{aligned}F_{2x} &= F_2 \cos \theta_2 = (40.0 \text{ N})(\cos 0.0^\circ) \\ &= 40.0 \text{ N}\end{aligned}$$

$$\begin{aligned}F_{2y} &= F_2 \sin \theta_2 = (40.0 \text{ N})(\sin 0.0^\circ) \\ &= 0.0 \text{ N}\end{aligned}$$

$$\begin{aligned}F_{3x} &= F_3 \cos \theta_3 = (80.0 \text{ N})(\cos 270.0^\circ) \\ &= 0.0 \text{ N}\end{aligned}$$

$$\begin{aligned}F_{3y} &= F_3 \sin \theta_3 = (80.0 \text{ N})(\sin 270.0^\circ) \\ &= -80.0 \text{ N}\end{aligned}$$

$$\begin{aligned}F_{4x} &= F_4 \cos \theta_4 = (40.0 \text{ N})(\cos 180.0^\circ) \\ &= -40.0 \text{ N}\end{aligned}$$

$$\begin{aligned}F_{4y} &= F_4 \sin \theta_4 = (40.0 \text{ N})(\sin 180.0^\circ) \\ &= 0.0 \text{ N}\end{aligned}$$

$$\begin{aligned}F_{5x} &= F_5 \cos \theta_5 = (50.0 \text{ N})(\cos 60.0^\circ) \\ &= 25.0 \text{ N}\end{aligned}$$

$$\begin{aligned}F_{5y} &= F_5 \sin \theta_5 = (50.0 \text{ N})(\sin 60.0^\circ) \\ &= 43.3 \text{ N}\end{aligned}$$

$$\begin{aligned}F_{6x} &= F_{1x} + F_{2x} + F_{3x} + F_{4x} + F_{5x} \\ &= 0.0 \text{ N} + 40.0 \text{ N} + 0.0 \text{ N} + \\ &\quad (-40.0 \text{ N}) + 25.0 \text{ N} \\ &= 25.0 \text{ N}\end{aligned}$$

$$\begin{aligned}F_{6y} &= F_{1y} + F_{2y} + F_{3y} + F_{4y} + F_{5y} \\ &= 60.0 \text{ N} + 0.0 \text{ N} + (-80.0 \text{ N}) + \\ &\quad 0.0 \text{ N} + 43.3 \text{ N} \\ &= 23.3 \text{ N}\end{aligned}$$

$$\begin{aligned}F_6 &= \sqrt{F_{6x}^2 + F_{6y}^2} \\ &= \sqrt{(25.0 \text{ N})^2 + (23.3 \text{ N})^2} \\ &= 34.2 \text{ N}\end{aligned}$$

$$\begin{aligned}\theta_6 &= \tan^{-1}\left(\frac{F_{6y}}{F_{6x}}\right) + 180.0^\circ \\ &= \tan^{-1}\left(\frac{23.3 \text{ N}}{25.0 \text{ N}}\right) + 180.0^\circ \\ &= 223^\circ\end{aligned}$$

$$F_6 = 34.2 \text{ N}, 223^\circ$$

97. **Advertising** Joe wishes to hang a sign weighing $7.50 \times 10^2 \text{ N}$ so that cable A, attached to the store, makes a 30.0° angle, as shown in **Figure 5-20**. Cable B is horizontal and attached to an adjoining building. What is the tension in cable B?

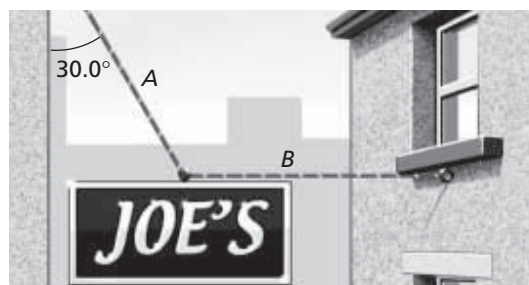

■ Figure 5-20

Chapter 5 continued

Solution by components. The sum of the components must equal zero, so

$$F_{Ay} - F_g = 0$$

$$\text{so } F_{Ay} = F_g$$

$$= 7.50 \times 10^2 \text{ N}$$

$$F_{Ay} = F_A \sin 60.0^\circ$$

$$\text{so } F_A = \frac{F_{Ay}}{\sin 60.0^\circ}$$

$$= \frac{7.50 \times 10^2 \text{ N}}{\sin 60.0^\circ}$$

$$= 866 \text{ N}$$

Also, $F_B - F_A = 0$, so

$$F_B = F_A$$

$$= F_A \cos 60.0^\circ$$

$$= (866 \text{ N})(\cos 60.0^\circ)$$

$$= 433 \text{ N, right}$$

- 98.** A street lamp weighs 150 N. It is supported by two wires that form an angle of 120.0° with each other. The tensions in the wires are equal.

- a.** What is the tension in each wire supporting the street lamp?

$$F_g = 2T \sin \theta$$

$$\text{so } T = \frac{F_g}{2 \sin \theta}$$

$$= \frac{150 \text{ N}}{(2)(\sin 30.0^\circ)}$$

$$= 1.5 \times 10^2 \text{ N}$$

- b.** If the angle between the wires supporting the street lamp is reduced to 90.0° , what is the tension in each wire?

$$T = \frac{F_g}{2 \sin \theta}$$

$$= \frac{150 \text{ N}}{(2)(\sin 45^\circ)}$$

$$= 1.1 \times 10^2 \text{ N}$$

- 99.** A 215-N box is placed on an inclined plane that makes a 35.0° angle with the horizontal. Find the component of the weight force parallel to the plane's surface.

$$F_{\text{parallel}} = F_g \sin \theta$$

$$= (215 \text{ N})(\sin 35.0^\circ)$$

$$= 123 \text{ N}$$

Level 3

- 100. Emergency Room** You are shadowing a nurse in the emergency room of a local hospital. An orderly wheels in a patient who has been in a very serious accident and has had severe bleeding. The nurse quickly explains to you that in a case like this, the patient's bed will be tilted with the head downward to make sure the brain gets enough blood. She tells you that, for most patients, the largest angle that the bed can be tilted without the patient beginning to slide off is 32.0° from the horizontal.

- a.** On what factor or factors does this angle of tilting depend?

The coefficient of static friction between the patient and the bed's sheets.

- b.** Find the coefficient of static friction between a typical patient and the bed's sheets.

$$F_{g \text{ parallel to bed}} = mg \sin \theta$$

$$= F_f$$

$$= \mu_s F_N$$

$$= \mu_s mg \cos \theta$$

$$\text{so } \mu_s = \frac{mg \sin \theta}{mg \cos \theta}$$

$$= \frac{\sin \theta}{\cos \theta}$$

$$= \tan \theta$$

$$= \tan 32.0^\circ$$

$$= 0.625$$

Chapter 5 continued

- 101.** Two blocks are connected by a string over a frictionless, massless pulley such that one is resting on an inclined plane and the other is hanging over the top edge of the plane, as shown in **Figure 5-21**. The hanging block has a mass of 16.0 kg, and the one on the plane has a mass of 8.0 kg. The coefficient of kinetic friction between the block and the inclined plane is 0.23. The blocks are released from rest.

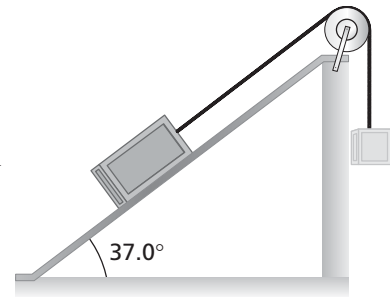

■ **Figure 5-21**

- a. What is the acceleration of the blocks?

$$F = m_{\text{both}}a = F_{g \text{ hanging}} - F_{\parallel \text{ plane}} - F_{f \text{ plane}}$$

so $a = \frac{m_{\text{hanging}}g - F_{g \text{ plane}} \sin \theta - \mu_k F_{g \text{ plane}} \cos \theta}{m_{\text{both}}}$

$$= \frac{m_{\text{hanging}}g - m_{\text{plane}}g \sin \theta - \mu_k m_{\text{plane}}g \cos \theta}{m_{\text{hanging}} + m_{\text{plane}}}$$

$$= \frac{(9.80 \text{ m/s}^2)(16.0 \text{ kg} - (8.0 \text{ kg})(\sin 37.0^\circ) - (0.23)(8.0 \text{ kg})(\cos 37.0^\circ))}{(16.0 \text{ kg} + 8.0 \text{ kg})}$$

$$= 4.0 \text{ m/s}^2$$

- b. What is the tension in the string connecting the blocks?

$$F_T = F_g - F_a$$

$$= mg - ma$$

$$= m(g - a)$$

$$= (16.0 \text{ kg})(9.80 \text{ m/s}^2 - 4.0 \text{ m/s}^2)$$

$$= 93 \text{ N}$$

- 102.** In **Figure 5-22**, a block of mass M is pushed with such a force, F , that the smaller block of mass m does not slide down the front of it. There is no friction between the larger block and the surface below it, but the coefficient of static friction between the two blocks is μ_s . Find an expression for F in terms of M , m , μ_s , and g .

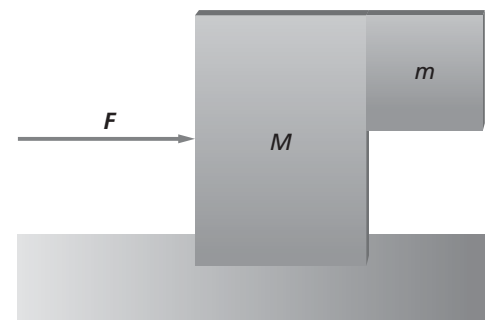

■ **Figure 5-22**

Smaller block:

$$F_{f, M \text{ on } m} = \mu_s F_{N, M \text{ on } m} = mg$$

$$F_{N, M \text{ on } m} = \frac{mg}{\mu_s} = ma$$

$$a = \frac{g}{\mu_s}$$

Chapter 5 continued

Larger block:

$$F - F_{N, m \text{ on } M} = Ma$$

$$F - \frac{mg}{\mu_s} = \frac{Mg}{\mu_s}$$

$$F = \frac{g}{\mu_s}(m + M)$$

Mixed Review

pages 143–144

Level 1

103. The scale in **Figure 5-23** is being pulled on by three ropes. What net force does the scale read?



Figure 5-7

Find the y -component of the two side ropes and then add them to the middle rope.

$$F_y = F \cos \theta$$

$$= (75.0 \text{ N})(\cos 27.0^\circ)$$

$$= 66.8 \text{ N}$$

$$F_{y, \text{ total}} = F_{y, \text{ left}} + F_{y, \text{ middle}} + F_{y, \text{ right}}$$

$$= 66.8 \text{ N} + 150.0 \text{ N} + 66.8 \text{ N}$$

$$= 283.6 \text{ N}$$

104. **Sledding** A sled with a mass of 50.0 kg is pulled along flat, snow-covered ground. The static friction coefficient is 0.30, and the kinetic friction coefficient is 0.10.

a. What does the sled weigh?

$$F_g = mg = (50.0 \text{ kg})(9.80 \text{ m/s}^2)$$

$$= 4.90 \times 10^2 \text{ N}$$

b. What force will be needed to start the sled moving?

$$F_f = \mu_s F_N$$

$$= \mu_s F_g$$

$$= (0.30)(4.90 \times 10^2 \text{ N})$$

$$= 1.5 \times 10^2 \text{ N}$$

c. What force is needed to keep the sled moving at a constant velocity?

$$F_f = \mu_s F_N$$

$$= \mu_s F_g$$

$$= (0.10)(4.90 \times 10^2 \text{ N})$$

$$= 49 \text{ N, kinetic friction}$$

d. Once moving, what total force must be applied to the sled to accelerate it at 3.0 m/s²?

$$ma = F_{\text{net}} = F_{\text{appl}} - F_f$$

$$\text{so } F_{\text{appl}} = ma + F_f$$

$$= (50.0 \text{ kg})(3.0 \text{ m/s}^2) + 49 \text{ N}$$

$$= 2.0 \times 10^2 \text{ N}$$

Level 2

105. **Mythology** Sisyphus was a character in Greek mythology who was doomed in Hades to push a boulder to the top of a steep mountain. When he reached the top, the boulder would slide back down the mountain and he would have to start all over again. Assume that Sisyphus slides the boulder up the mountain without being able to roll it, even though in most versions of the myth, he rolled it.

a. If the coefficient of kinetic friction between the boulder and the mountain-side is 0.40, the mass of the boulder is 20.0 kg, and the slope of the mountain is a constant 30.0°, what is the force that Sisyphus must exert on the boulder to move it up the mountain at a constant velocity?

$$F_{S \text{ on rock}} - F_{g \parallel \text{to slope}} - F_f$$

$$= F_{S \text{ on rock}} - mg \sin \theta -$$

$$\mu_k mg \cos \theta = ma = 0$$

$$F_{S \text{ on rock}} = mg \sin \theta + \mu_k mg \cos \theta$$

Chapter 5 continued

$$\begin{aligned}
 &= mg(\sin \theta + \mu_k \cos \theta) \\
 &= (20.0 \text{ kg})(9.80 \text{ m/s}^2) \\
 &\quad (\sin 30.0^\circ + (0.40)(\cos 30.0^\circ)) \\
 &= 166 \text{ N}
 \end{aligned}$$

- b. If Sisyphus pushes the boulder at a velocity of 0.25 m/s and it takes him 8.0 h to reach the top of the mountain, what is the mythical mountain's vertical height?

$$\begin{aligned}
 h &= d \sin \theta \\
 &= vt \sin \theta \\
 &= (0.25 \text{ m/s})(8.0 \text{ h})(3600 \text{ s/h})(\sin 30.0^\circ) \\
 &= 3.6 \times 10^3 \text{ m} = 3.6 \text{ km}
 \end{aligned}$$

Level 3

106. Landscaping A tree is being transported on a flatbed trailer by a landscaper, as shown in **Figure 5-24**. If the base of the tree slides on the tree will the trailer, fall over and be damaged. If the coefficient of static friction between the tree and the trailer is 0.50, what is the minimum stopping distance of the truck, traveling at 55 km/h, if it is to accelerate uniformly and not have the tree slide forward and fall on the trailer?

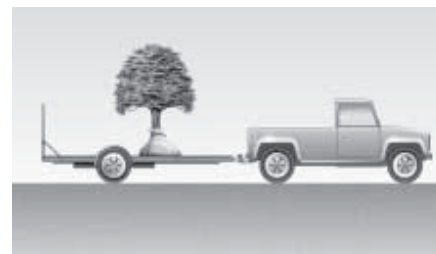

■ Figure 5-24

$$F_{\text{truck}} = -F_f = -\mu_s F_N = -\mu_s mg = ma$$

$$a = \frac{-\mu_s mg}{m} = -\mu_s g$$

$$= -(0.50)(9.80 \text{ m/s}^2)$$

$$= -4.9 \text{ m/s}^2$$

$$v_f^2 = v_i^2 + 2a\Delta d \text{ with } v_f = 0,$$

$$\text{so } \Delta d = -\frac{v_i^2}{2a}$$

$$= \frac{-\left((55 \text{ km/h})\left(\frac{1000 \text{ m}}{1 \text{ km}}\right)\left(\frac{1 \text{ h}}{3600 \text{ s}}\right)\right)^2}{(2)(-4.9 \text{ m/s}^2)}$$

$$= 24 \text{ m}$$

Thinking Critically

page 144

107. Use Models Using the Example Problems in this chapter as models, write an example problem to solve the following problem. Include the following sections: Analyze and Sketch the Problem, Solve for the Unknown (with a complete strategy), and Evaluate the Answer. A driver of a 975-kg car traveling 25 m/s puts on the brakes. What is the shortest distance it will take for the car to stop? Assume that the road is concrete, the force of friction of the road on the tires is constant, and the tires do not slip.

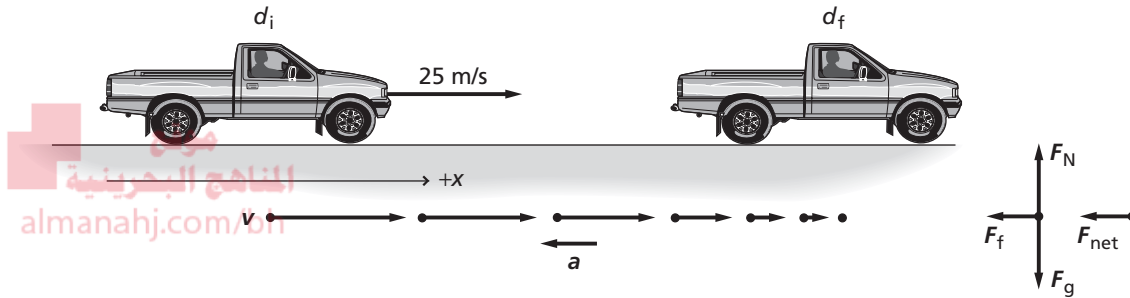

Analyze and Sketch the Problem

- Choose a coordinate system with a positive axis in the direction of motion.
- Draw a motion diagram.
- Label v and a .
- Draw the free-body diagram.

Known: Unknown:

$$d_i = 0 \qquad d_f = ?$$

$$v_i = 25 \text{ m/s}$$

$$v_f = 0$$

$$m = 975 \text{ kg}$$

$$\mu_s = 0.80$$

Solve for the Unknown

Solve Newton's second law for a .

$$-F_{\text{net}} = ma$$

$$-F_f = ma \qquad \text{Substitute } -F_f = -F_{\text{net}}$$

$$-\mu F_N = ma \qquad \text{Substitute } F_f = \mu F_N$$

$$-\mu mg = ma \qquad \text{Substitute } F_N = mg$$

$$a = -\mu g$$

Use the expression for acceleration to solve for distance.

$$v_f^2 = v_i^2 + 2a(d_f - d_i)$$

$$d_f = d_i + \frac{v_f^2 - v_i^2}{2a}$$

$$= d_i + \frac{v_f^2 - v_i^2}{(2)(-\mu g)} \qquad \text{Substitute } a = -\mu g$$

Chapter 5 continued

$$\begin{aligned} &= 0.0 \text{ m} + \frac{(0.0 \text{ m/s})^2 - (25 \text{ m/s})^2}{(2)(-0.65)(9.80 \text{ m/s}^2)} \\ &= 49 \text{ m} \end{aligned}$$

$$\begin{aligned} \text{Substitute } d_i &= 0.0 \text{ m}, v_f = 0.0 \text{ m/s}, \\ v_i &= 25 \text{ m/s}, \mu = 0.65, g = 9.80 \text{ m/s}^2 \end{aligned}$$

- 108. Analyze and Conclude** Margaret Mary, Doug, and Kako are at a local amusement park and see an attraction called the Giant Slide, which is simply a very long and high inclined plane. Visitors at the amusement park climb a long flight of steps to the top of the 27° inclined plane and are given canvas sacks. They sit on the sacks and slide down the 70-m-long plane. At the time when the three friends walk past the slide, a 135-kg man and a 20-kg boy are each at the top preparing to slide down. "I wonder how much less time it will take the man to slide down than it will take the boy," says Margaret Mary. "I think the boy will take less time," says Doug. "You're both wrong," says Kako. "They will reach the bottom at the same time."

- a. Perform the appropriate analysis to determine who is correct.

$$\begin{aligned} F_{\text{net}} &= F_g - F_f \\ &= F_g \sin \theta - \mu_k F_N \\ &= mg \sin \theta - \mu_k mg \cos \theta = ma \end{aligned}$$

$a = g(\sin \theta - \mu_k \cos \theta)$, so the acceleration is independent of the mass. They will tie, so Kako is correct.

- b. If the man and the boy do not take the same amount of time to reach the of the slide, calculate how many seconds of difference there will be between the two times.

They will reach the bottom at the same time.

Writing in Physics

page 144

- 109.** Investigate some of the techniques used in industry to reduce the friction between various parts of machines. Describe two or three of these techniques and explain the physics of how they work.

Answers will vary and may include lubricants and reduction of the normal force to reduce the force of friction.

- 110. Olympics** In recent years, many Olympic athletes, such as sprinters, swimmers, skiers, and speed skaters, have used modified equipment to reduce the effects of friction and air or water drag. Research a piece of equipment used by one of these types of athletes and the way it has changed over the years. Explain how physics has impacted these changes.

Answers will vary.

Chapter 5 continued

Cumulative Review

page 144

111. Add or subtract as indicated and state the answer with the correct number of significant digits. (Chapter 1)

- a. $85.26 \text{ g} + 4.7 \text{ g}$
90.0 g
- b. $1.07 \text{ km} + 0.608 \text{ km}$
1.68 km
- c. $186.4 \text{ kg} - 57.83 \text{ kg}$
128.6 kg
- d. $60.08 \text{ s} - 12.2 \text{ s}$
47.9 s

112. You ride your bike for 1.5 h at an average velocity of 10 km/h, then for 30 min at 15 km/h. What is your average velocity? (Chapter 3)

Average velocity is the total displacement divided by the total time.

$$\bar{v} = \frac{d_f - d_i}{t_f - t_i}$$

$$= \frac{v_1 t_1 + v_2 t_2 - d_i}{t_1 + t_2 - t_i}$$

$$d_i = t_i = 0, \text{ so}$$

$$\bar{v} = \frac{v_1 t_1 + v_2 t_2}{t_1 + t_2}$$

$$= \frac{(10 \text{ km/h})(1.5 \text{ h}) + (15 \text{ km/h})(0.5 \text{ h})}{1.5 \text{ h} + 0.5 \text{ h}}$$

$$= 10 \text{ km/h}$$

113. A 45-N force is exerted in the upward direction on a 2.0-kg briefcase. What is the acceleration of the briefcase? (Chapter 4)

$$F_{\text{net}} = F_{\text{applied}} - F_g = F_{\text{applied}} - mg$$

$$= ma$$

$$\text{so } a = \frac{F_{\text{applied}} - mg}{m}$$

$$= \frac{45 \text{ N} - (2.0 \text{ kg})(9.80 \text{ m/s}^2)}{2.0 \text{ kg}}$$

$$= 13 \text{ m/s}^2$$

Challenge Problem

page 132

Find the equilibrant for the following forces.

$$F_1 = 61.0 \text{ N at } 17.0^\circ \text{ north of east}$$

$$F_2 = 38.0 \text{ N at } 64.0^\circ \text{ north of east}$$

$$F_3 = 54.0 \text{ N at } 8.0^\circ \text{ west of north}$$

$$F_4 = 93.0 \text{ N at } 53.0^\circ \text{ west of north}$$

$$F_5 = 65.0 \text{ N at } 21.0^\circ \text{ south of west}$$

$$F_6 = 102.0 \text{ N at } 15.0^\circ \text{ west of south}$$

$$F_7 = 26.0 \text{ N south}$$

$$F_8 = 77.0 \text{ N at } 22.0^\circ \text{ east of south}$$

$$F_9 = 51.0 \text{ N at } 33.0^\circ \text{ east of south}$$

$$F_{10} = 82.0 \text{ N at } 5.0^\circ \text{ south of east}$$

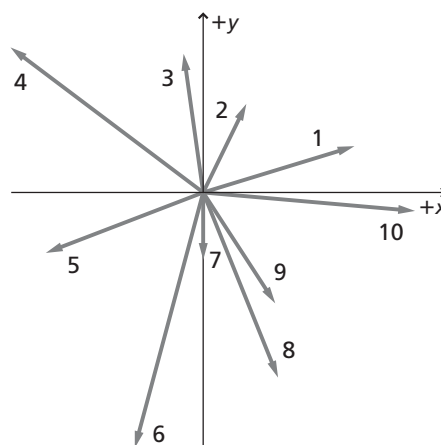

$$F_{1x} = (61.0 \text{ N})(\cos 17.0^\circ) = 58.3 \text{ N}$$

$$F_{1y} = (61.0 \text{ N})(\sin 17.0^\circ) = 17.8 \text{ N}$$

$$F_{2x} = (38.0 \text{ N})(\cos 64.0^\circ) = 16.7 \text{ N}$$

$$F_{2y} = (38.0 \text{ N})(\sin 64.0^\circ) = 34.2 \text{ N}$$

$$F_{3x} = -(54.0 \text{ N})(\sin 8.0^\circ) = -7.52 \text{ N}$$

$$F_{3y} = (54.0 \text{ N})(\cos 8.0^\circ) = 53.5 \text{ N}$$

$$F_{4x} = -(93.0 \text{ N})(\sin 53.0^\circ) = -74.3 \text{ N}$$

$$F_{4y} = (93.0 \text{ N})(\cos 53.0^\circ) = 56.0 \text{ N}$$

$$F_{5x} = -(65.0 \text{ N})(\cos 21.0^\circ) = -60.7 \text{ N}$$

$$F_{5y} = -(65.0 \text{ N})(\sin 21.0^\circ) = -23.3 \text{ N}$$

$$F_{6x} = -(102 \text{ N})(\sin 15.0^\circ) = -26.4 \text{ N}$$

$$F_{6y} = -(102 \text{ N})(\cos 15.0^\circ) = -98.5 \text{ N}$$

Chapter 5 continued

$$F_{7x} = 0.0 \text{ N}$$

$$F_{7y} = -26.0 \text{ N}$$

$$F_{8x} = (77.0 \text{ N})(\sin 22.0^\circ) = 28.8 \text{ N}$$

$$F_{8y} = -(77.0 \text{ N})(\cos 22.0^\circ) = -71.4 \text{ N}$$

$$F_{9x} = (51.0 \text{ N})(\sin 33.0^\circ) = 27.8 \text{ N}$$

$$F_{9y} = -(51.0 \text{ N})(\cos 33.0^\circ) = -42.8 \text{ N}$$

$$F_{10x} = (82.0 \text{ N})(\cos 5.0^\circ) = 81.7 \text{ N}$$

$$F_{10y} = -(82.0 \text{ N})(\sin 5.0^\circ) = -7.15 \text{ N}$$

$$F_x = \sum_{i=1}^{10} F_{ix} = 44.38 \text{ N}$$

$$F_y = \sum_{i=1}^{10} F_{iy} = -107.65 \text{ N}$$

$$F_R = \sqrt{(F_x)^2 + (F_y)^2} = \sqrt{(44.38 \text{ N})^2 + (-107.65 \text{ N})^2} = 116 \text{ N}$$

$$\theta_R = \tan^{-1}\left(\frac{F_y}{F_x}\right) = \tan^{-1}\left(\frac{-107.65 \text{ N}}{44.38 \text{ N}}\right) = -67.6^\circ$$

$$F_{\text{equilibrant}} = 116 \text{ N at } 112.4^\circ = 116 \text{ N at } 22.4^\circ \text{ W of N}$$

Practice Problems

6.1 Projectile Motion
pages 147–152

page 150

1. A stone is thrown horizontally at a speed of 5.0 m/s from the top of a cliff that is 78.4 m high.
- a. How long does it take the stone to reach the bottom of the cliff?

Since $v_y = 0$, $y - v_y t = -\frac{1}{2}gt^2$

becomes $y = -\frac{1}{2}gt^2$

$$\begin{aligned} \text{or } t &= \sqrt{-\frac{2y}{g}} \\ &= \sqrt{\frac{-(2)(-78.4 \text{ m})}{9.80 \text{ m/s}^2}} \\ &= 4.00 \text{ s} \end{aligned}$$

- b. How far from the base of the cliff does the stone hit the ground?

$$\begin{aligned} x &= v_x t \\ &= (5.0 \text{ m/s})(4.00 \text{ s}) \\ &= 2.0 \times 10^1 \text{ m} \end{aligned}$$

- c. What are the horizontal and vertical components of the stone's velocity just before it hits the ground?

$v_x = 5.0 \text{ m/s}$. This is the same as the initial horizontal speed because the acceleration of gravity influences only the vertical motion. For the vertical component, use $v = v_i + gt$ with $v = v_y$ and v_i , the initial vertical component of velocity, zero.

$$\begin{aligned} \text{At } t &= 4.00 \text{ s} \\ v_y &= gt \\ &= (9.80 \text{ m/s}^2)(4.0 \text{ s}) \\ &= 39.2 \text{ m/s} \end{aligned}$$

2. Lucy and her friend are working at an assembly plant making wooden toy giraffes. At the end of the line, the giraffes go horizontally off the edge of the conveyor belt and fall into a box below. If the box is 0.6 m below the level of the conveyor belt and 0.4 m away from it, what must be the horizontal velocity of giraffes as they leave the conveyor belt?

$$x = v_x t = v_x \sqrt{\frac{-2y}{g}}$$

$$\begin{aligned} \text{so } v_x &= \frac{x}{\sqrt{\frac{-2y}{g}}} \\ &= \frac{0.4 \text{ m}}{\sqrt{\frac{(-2)(-0.6 \text{ m})}{9.80 \text{ m/s}^2}}} \\ &= 1 \text{ m/s} \end{aligned}$$

3. You are visiting a friend from elementary school who now lives in a small town. One local amusement is the ice-cream parlor, where Stan, the short-order cook, slides his completed ice-cream sundaes down the counter at a constant speed of 2.0 m/s to the servers. (The counter is kept very well polished for this purpose.) If the servers catch the sundaes 7.0 cm from the edge of the counter, how far do they fall from the edge of the counter to the point at which the servers catch them?

$$x = v_x t;$$

$$t = \frac{x}{v_x}$$

$$\begin{aligned} y &= -\frac{1}{2}gt^2 \\ &= -\frac{1}{2}g\left(\frac{x}{v_x}\right)^2 \\ &= -\frac{1}{2}(9.80 \text{ m/s}^2)\left(\frac{0.070 \text{ m}}{2.0 \text{ m/s}}\right)^2 \\ &= 0.0060 \text{ m or } 0.60 \text{ cm} \end{aligned}$$

Chapter 6 continued

page 152

4. A player kicks a football from ground level with an initial velocity of 27.0 m/s, 30.0° above the horizontal, as shown in **Figure 6-4**. Find each of the following. Assume that air resistance is negligible.

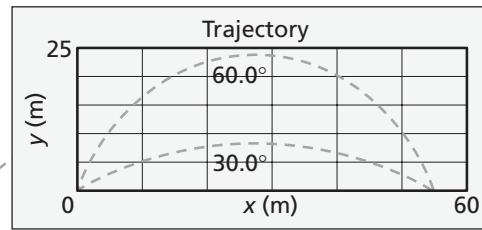

■ Figure 6-4

- a. the ball's hang time

$$v_y = v_i \sin \theta$$

$$\text{When it lands, } y = v_y t - \frac{1}{2} g t^2 = 0.$$

Therefore,

$$t^2 = \frac{2v_y t}{g}$$

$$t = \frac{2v_y}{g}$$

$$= \frac{2v_i \sin \theta}{g}$$

$$= \frac{(2)(27.0 \text{ m/s})(\sin 30.0^\circ)}{9.80 \text{ m/s}^2}$$

$$= 2.76 \text{ s}$$

- b. the ball's maximum height

Maximum height occurs at half the "hang time," or 1.38 s. Thus,

$$y = v_y t - \frac{1}{2} g t^2$$

$$= v_i \sin \theta t - \frac{1}{2} g t^2$$

$$= (27.0 \text{ m/s})(\sin 30.0^\circ)(1.38 \text{ s}) - \frac{1}{2} (+9.80 \text{ m/s}^2)(1.38 \text{ s})^2$$

$$= 9.30 \text{ m}$$

- c. the ball's range

Distance:

$$v_x = v_i \cos \theta$$

$$x = v_x t = (v_i \cos \theta)(t) = (27.0 \text{ m/s})(\cos 30.0^\circ)(2.76 \text{ s}) = 64.5 \text{ m}$$

5. The player in problem 4 then kicks the ball with the same speed, but at 60.0° from the horizontal. What is the ball's hang time, range, and maximum height?

Following the method of Practice Problem 4,

Hangtime:

$$t = \frac{2v_i \sin \theta}{g}$$

$$= \frac{(2)(27.0 \text{ m/s})(\sin 60.0^\circ)}{9.80 \text{ m/s}^2}$$

$$= 4.77 \text{ s}$$

Chapter 6 continued

Distance:

$$\begin{aligned}x &= v_i \cos \theta t \\ &= (27.0 \text{ m/s})(\cos 60.0^\circ)(4.77 \text{ s}) \\ &= 64.4 \text{ m}\end{aligned}$$

Maximum height:

$$\text{at } t = \frac{1}{2}(4.77 \text{ s}) = 2.38 \text{ s}$$

$$\begin{aligned}y &= v_i \sin \theta t - \frac{1}{2}gt^2 \\ &= (27.0 \text{ m/s})(\sin 60.0^\circ)(2.38 \text{ s}) - \frac{1}{2}(+9.80 \text{ m/s}^2)(2.38 \text{ s})^2 \\ &= 27.9 \text{ m}\end{aligned}$$

6. A rock is thrown from a 50.0-m-high cliff with an initial velocity of 7.0 m/s at an angle of 53.0° above the horizontal. Find the velocity vector for when it hits the ground below.

$$v_x = v_i \cos \theta$$

$$v_y = v_i \sin \theta + gt$$

$$= v_i \sin \theta + g\sqrt{\frac{2y}{g}}$$

$$= v_i \sin \theta + \sqrt{2yg}$$

$$v = \sqrt{v_x^2 + v_y^2}$$

$$= \sqrt{(v_i \cos \theta)^2 + (v_i \sin \theta + \sqrt{2yg})^2}$$

$$= \sqrt{((7.0 \text{ m/s}) \cos 53.0^\circ)^2 + \left((7.0 \text{ m/s})(\sin 53.0^\circ) + \sqrt{(2)(50.0 \text{ m})(9.80 \text{ m/s}^2)}\right)^2}$$

$$= 37 \text{ m/s}$$

$$\theta = \tan^{-1}\left(\frac{v_y}{v_x}\right)$$

$$= \tan^{-1}\left(\frac{v_i \sin \theta_i + \sqrt{2yg}}{v_i \cos \theta_i}\right)$$

$$= \tan^{-1}\left(\frac{(7.0 \text{ m/s})(\sin 53.0^\circ) + \sqrt{(2)(50.0 \text{ m})(9.80 \text{ m/s}^2)}}{(7.0 \text{ m/s})(\cos 53.0^\circ)}\right)$$

$$= 83^\circ \text{ from horizontal}$$

Section Review

6.1 Projectile Motion pages 147–152

page 152

7. **Projectile Motion** Two baseballs are pitched horizontally from the same height, but at different speeds. The faster ball crosses home plate within the strike zone, but the slower ball is below the batter's knees. Why does the faster ball not fall as far as the slower one?

Chapter 6 continued

The faster ball is in the air a shorter time, and thus gains a smaller vertical velocity.

8. **Free-Body Diagram** An ice cube slides without friction across a table at a constant velocity. It slides off the table and lands on the floor. Draw free-body and motion diagrams of the ice cube at two points on the table and at two points in the air.

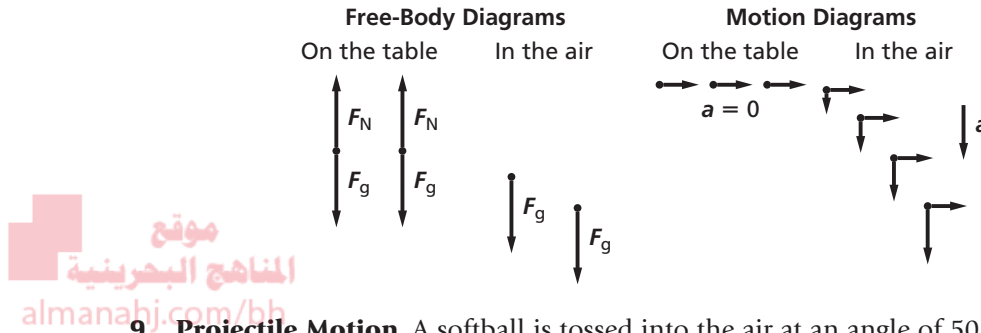

9. **Projectile Motion** A softball is tossed into the air at an angle of 50.0° with the vertical at an initial velocity of 11.0 m/s . What is its maximum height?

$$v_f^2 = v_{iy}^2 + 2a(d_f - d_i); a = -g, d_i = 0$$

At maximum height $v_f = 0$, so

$$\begin{aligned} d_f &= \frac{v_{iy}^2}{2g} \\ &= \frac{(v_i \cos \theta)^2}{2g} \\ &= \frac{((11.0 \text{ m/s})(\cos 50.0^\circ))^2}{(2)(9.80 \text{ m/s}^2)} \\ &= 2.55 \text{ m} \end{aligned}$$

10. **Projectile Motion** A tennis ball is thrown out a window 28 m above the ground at an initial velocity of 15.0 m/s and 20.0° below the horizontal. How far does the ball move horizontally before it hits the ground?

$$x = v_{0x}t, \text{ but need to find } t$$

First, determine v_{yf} :

$$\begin{aligned} v_{yf}^2 &= v_{yi}^2 + 2gy \\ v_{yf} &= \sqrt{v_{yi}^2 + 2gy} \\ &= \sqrt{(v_i \sin \theta)^2 + 2gy} \\ &= \sqrt{((15.0 \text{ m/s})(\sin 20.0^\circ))^2 + (2)(9.80 \text{ m/s}^2)(28 \text{ m})} \\ &= 24.0 \text{ m/s} \end{aligned}$$

Now use $v_{yf} = v_{yi} + gt$ to find t .

$$\begin{aligned} t &= \frac{v_{yf} - v_{yi}}{g} \\ &= \frac{v_{yf} - v_i \sin \theta}{g} \end{aligned}$$

Chapter 6 continued

$$= \frac{2.40 \text{ m/s} - (15.0 \text{ m/s})(\sin 20.0^\circ)}{9.80 \text{ m/s}^2}$$

$$= 1.92 \text{ s}$$

$$x = v_{xi}t$$

$$= (v_i \cos \theta)(t)$$

$$= (15.0 \text{ m/s})(\cos 20.0^\circ)(1.92 \text{ s})$$

$$= 27.1 \text{ m}$$

- 11. Critical Thinking** Suppose that an object is thrown with the same initial velocity and direction on Earth and on the Moon, where g is one-sixth that on Earth. How will the following quantities change?

a. v_x

will not change

b. the object's time of flight

will be larger; $t = \frac{-2v_y}{g}$

c. y_{\max}

will be larger

d. R

will be larger

Practice Problems

6.2 Circular Motion pages 153–156

page 156

- 12.** A runner moving at a speed of 8.8 m/s rounds a bend with a radius of 25 m. What is the centripetal acceleration of the runner, and what agent exerts force on the runner?

$$a_c = \frac{v^2}{r} = \frac{(8.8 \text{ m/s})^2}{25 \text{ m}} = 3.1 \text{ m/s}^2, \text{ the frictional force of the track acting on}$$

the runner's shoes exerts the force on the runner.

- 13.** A car racing on a flat track travels at 22 m/s around a curve with a 56-m radius. Find the car's centripetal acceleration. What minimum coefficient of static friction between the tires and road is necessary for the car to round the curve without slipping?

$$a_c = \frac{v^2}{r} = \frac{(22 \text{ m/s})^2}{56 \text{ m}} = 8.6 \text{ m/s}^2$$

Recall $F_f = \mu F_N$. The friction force must supply the centripetal force so $F_f = ma_c$. The normal force is $F_N = -mg$. The coefficient of friction must be at least

$$\mu = \frac{F_f}{F_N} = \frac{ma_c}{mg} = \frac{a_c}{g} = \frac{8.6 \text{ m/s}^2}{9.80 \text{ m/s}^2} = 0.88$$

Chapter 6 continued

14. An airplane traveling at 201 m/s makes a turn. What is the smallest radius of the circular path (in km) that the pilot can make and keep the centripetal acceleration under 5.0 m/s^2 ?

$$a_c = \frac{v^2}{r}, \text{ so } r = \frac{v^2}{a_c} = \frac{(201 \text{ m/s})^2}{5.0 \text{ m/s}^2} = 8.1 \text{ km}$$

15. A 45-kg merry-go-round worker stands on the ride's platform 6.3 m from the center. If her speed as she goes around the circle is 4.1 m/s, what is the force of friction necessary to keep her from falling off the platform?

$$F_f = F_c = \frac{mv^2}{r} = \frac{(45 \text{ kg})(4.1 \text{ m/s})^2}{6.3 \text{ m}} = 120 \text{ N}$$

Section Review

6.2 Circular Motion pages 153–156

page 156

16. **Uniform Circular Motion** What is the direction of the force that acts on the clothes in the spin cycle of a washing machine? What exerts the force?
The force is toward the center of the tub. The walls of the tub exert the force on the clothes. Of course, the whole point is that some of the water in the clothes goes out through holes in the wall of the tub rather than moving toward the center.
17. **Free-Body Diagram** You are sitting in the backseat of a car going around a curve to the right. Sketch motion and free-body diagrams to answer the following questions.

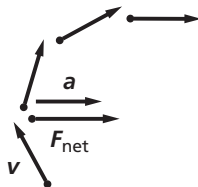

- a. What is the direction of your acceleration?
Your body is accelerated to the right.

- b. What is the direction of the net force that is acting on you?
The net force acting on your body is to the right
- c. What exerts this force?
The force is exerted by the car's seat.

18. **Centripetal Force** If a 40.0-g stone is whirled horizontally on the end of a 0.60-m string at a speed of 2.2 m/s, what is the tension in the string?

$$\begin{aligned} F_T &= ma_c \\ &= \frac{mv^2}{r} \\ &= \frac{(0.0400 \text{ kg})(2.2 \text{ m/s})^2}{0.60 \text{ m}} \\ &= 0.32 \text{ N} \end{aligned}$$

19. **Centripetal Acceleration** A newspaper article states that when turning a corner, a driver must be careful to balance the centripetal and centrifugal forces to keep from skidding. Write a letter to the editor that critiques this article.

The letter should state that there is an acceleration because the direction of the velocity is changing; therefore, there must be a net force in the direction of the center of the circle. The road supplies that force and the friction between the road and the tires allows the force to be exerted on the tires. The car's seat exerts the force on the driver that accelerates him or her toward the center of the circle. The note also should make it clear that centrifugal force is not a real force.

20. **Centripetal Force** A bowling ball has a mass of 7.3 kg. If you move it around a circle with a radius of 0.75 m at a speed of 2.5 m/s, what force would you have to exert on it?

$$\begin{aligned} F_{\text{net}} &= ma_c \\ &= \frac{mv^2}{r} \end{aligned}$$

Chapter 6 continued

$$\begin{aligned} &= \frac{(7.3 \text{ kg})(2.5 \text{ m/s})^2}{0.75 \text{ m}} \\ &= 61 \text{ N} \end{aligned}$$

- 21. Critical Thinking** Because of Earth's daily rotation, you always move with uniform circular motion. What is the agent that supplies the force that accelerates you? How does this motion affect your apparent weight?

Earth's gravity supplies the force that accelerates you in circular motion. Your uniform circular motion decreases your apparent weight.

Practice Problems

6.3 Relative Velocity pages 157–159

page 159

- 22.** You are riding in a bus moving slowly through heavy traffic at 2.0 m/s. You hurry to the front of the bus at 4.0 m/s relative to the bus. What is your speed relative to the street?

$$\begin{aligned} v_{y/g} &= v_{b/g} + v_{y/b} \\ &= 2.0 \text{ m/s} + 4.0 \text{ m/s} \\ &= 6.0 \text{ m/s relative to street} \end{aligned}$$

- 23.** Rafi is pulling a toy wagon through the neighborhood at a speed of 0.75 m/s. A caterpillar in the wagon is crawling toward the rear of the wagon at a rate of 2.0 cm/s. What is the caterpillar's velocity relative to the ground?

$$\begin{aligned} v_{c/g} &= v_{w/g} + v_{c/w} \\ &= 0.75 \text{ m/s} - 0.02 \text{ m/s} \\ &= 0.73 \text{ m/s} \end{aligned}$$

- 24.** A boat is rowed directly upriver at a speed of 2.5 m/s relative to the water. Viewers on the shore see that the boat is moving at only 0.5 m/s relative to the shore. What is the speed of the river? Is it moving with or against the boat?

$$v_{b/g} = v_{b/w} + v_{w/g}$$

$$\begin{aligned} \text{so, } v_{w/g} &= v_{b/g} - v_{b/w} \\ &= 0.5 \text{ m/s} - 2.5 \text{ m/s} \\ &= 2.0 \text{ m/s; against the boat} \end{aligned}$$

- 25.** An airplane flies due north at 150 km/h relative to the air. There is a wind blowing at 75 km/h to the east relative to the ground. What is the plane's speed relative to the ground?

$$\begin{aligned} v &= \sqrt{v_p^2 + v_w^2} \\ &= \sqrt{(150 \text{ km/h})^2 + (75 \text{ km/h})^2} \\ &= 1.7 \times 10^2 \text{ km/h} \end{aligned}$$

Section Review

6.3 Relative Velocity pages 157–159

page 159

- 26. Relative Velocity** A fishing boat with a maximum speed of 3 m/s relative to the water is in a river that is flowing at 2 m/s. What is the maximum speed the boat can obtain relative to the shore? The minimum speed? Give the direction of the boat, relative to the river's current, for the maximum speed and the minimum speed relative to the shore.

The maximum speed relative to the shore is when the boat moves at maximum speed in the same direction as the river's flow:

$$\begin{aligned} v_{b/s} &= v_{b/w} + v_{w/s} \\ &= 3 \text{ m/s} + 2 \text{ m/s} \\ &= 5 \text{ m/s} \end{aligned}$$

The minimum speed relative to the shore is when the boat moves in the opposite direction of the river's flow with the same speed as the river:

$$\begin{aligned} v_{b/s} &= v_{b/w} + v_{w/s} \\ &= 3 \text{ m/s} + (-2 \text{ m/s}) \\ &= 1 \text{ m/s} \end{aligned}$$

Chapter 6 continued

- 27. Relative Velocity of a Boat** A powerboat heads due northwest at 13 m/s relative to the water across a river that flows due north at 5.0 m/s. What is the velocity (both magnitude and direction) of the motorboat relative to the shore?

$$\begin{aligned} v_R &= \sqrt{v_{RN}^2 + v_{RW}^2} \\ &= \sqrt{(v_{bN} + v_{rN})^2 + (v_{bW} + v_{rW})^2} \\ &= \sqrt{(v_b \sin \theta + v_r)^2 + (v_b \cos \theta)^2} \\ &= \sqrt{((13 \text{ m/s})(\sin 45^\circ) + 5.0 \text{ m/s})^2 + ((13 \text{ m/s})(\cos 45^\circ))^2} = 17 \text{ m/s} \end{aligned}$$

$$\begin{aligned} \theta &= \tan^{-1}\left(\frac{v_{RW}}{v_{RN}}\right) \\ &= \tan^{-1}\left(\frac{v_b \cos \theta}{v_b \sin \theta + v_r}\right) \\ &= \tan^{-1}\left(\frac{(13 \text{ m/s})(\cos 45^\circ)}{(3 \text{ m/s})(\sin 45^\circ) + 5.0 \text{ m/s}}\right) \\ &= 33^\circ \end{aligned}$$

$$v_R = 17 \text{ m/s}, 33^\circ \text{ west of north}$$

- 28. Relative Velocity** An airplane flies due south at 175 km/h relative to the air. There is a wind blowing at 85 km/h to the east relative to the ground. What are the plane's speed and direction relative to the ground?

$$v_R = \sqrt{(175 \text{ km/h})^2 + (85 \text{ km/h})^2} = 190 \text{ km/h}$$

$$\theta = \tan^{-1}\left(\frac{175 \text{ km/h}}{85 \text{ km/h}}\right) = 64^\circ$$

$$v_R = 190 \text{ km/h}, 64^\circ \text{ south of east}$$

- 29. A Plane's Relative Velocity** An airplane flies due north at 235 km/h relative to the air. There is a wind blowing at 65 km/h to the northeast relative to the ground. What are the plane's speed and direction relative to the ground?

$$\begin{aligned} v_R &= \sqrt{v_{RE}^2 + v_{RN}^2} \\ &= \sqrt{(v_{pE} + v_{aE})^2 + (v_{pN} + v_{wN})^2} \\ &= \sqrt{(v_w \cos \theta)^2 + (v_p + v_w \sin \theta)^2} \\ &= \sqrt{((65 \text{ km/h})(\cos 45^\circ))^2 + (235 \text{ km/h} + (65 \text{ km/h})(\sin 45^\circ))^2} = 280 \text{ km/h} \end{aligned}$$

$$\begin{aligned} \theta &= \tan^{-1}\left(\frac{v_{RN}}{v_{RE}}\right) \\ &= \tan^{-1}\left(\frac{v_p + v_a \sin \theta}{v_a \cos \theta}\right) \\ &= \tan^{-1}\left(\frac{235 \text{ km/h} + (65 \text{ km/h})(\sin 45^\circ)}{(65 \text{ km/h})(\cos 45^\circ)}\right) \\ &= 72^\circ \text{ north of east} \end{aligned}$$

$$280 \text{ km/h}, 72^\circ \text{ north of east}$$

Chapter 6 continued

- 30. Relative Velocity** An airplane has a speed of 285 km/h relative to the air. There is a wind blowing at 95 km/h at 30.0° north of east relative to Earth. In which direction should the plane head to land at an airport due north of its present location? What is the plane's speed relative to the ground?

To travel north, the east components must be equal and opposite.

$$\cos \theta_p = \frac{v_{pW}}{v_{pR}}, \text{ so}$$

$$\theta_p = \cos^{-1}\left(\frac{v_{pW}}{v_{pR}}\right)$$

$$= \cos^{-1}\left(\frac{v_{wE} \cos \theta_w}{v_{pR}}\right)$$

$$= \cos^{-1}\left(\frac{(95 \text{ km/h})(\cos 30.0^\circ)}{285 \text{ km/h}}\right)$$

$$= 73^\circ \text{ north of west}$$

$$v_{pR} = v_{pN} + v_{wN}$$

$$= v_p \sin \theta_p + v_w \sin \theta_w$$

$$= (285 \text{ km/h})(\sin 107^\circ) + (95 \text{ km/h})(\sin 30.0^\circ)$$

$$= 320 \text{ km/h}$$

- 31. Critical Thinking** You are piloting a boat across a fast-moving river. You want to reach a pier directly opposite your starting point. Describe how you would navigate the boat in terms of the components of your velocity relative to the water.

You should choose the component of your velocity along the direction of the river to be equal and opposite to the velocity of the river.

Chapter Assessment

Concept Mapping

page 164

- 32.** Use the following terms to complete the concept map below: *constant speed*, *horizontal part of projectile motion*, *constant acceleration*, *relative-velocity motion*, *uniform circular motion*.

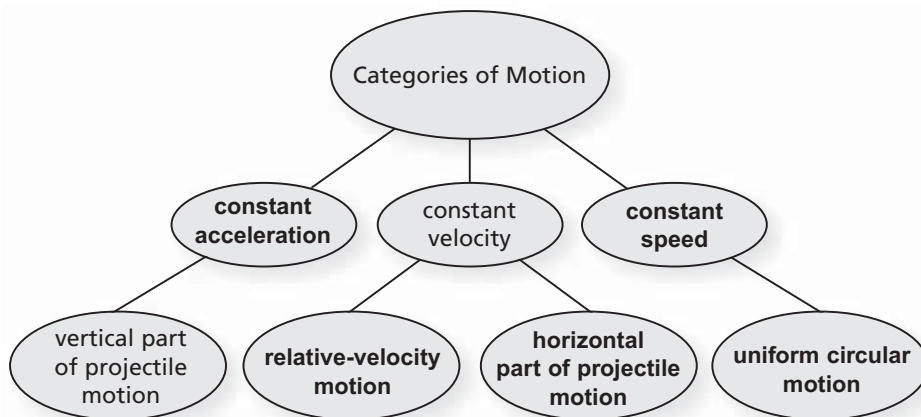

Mastering Concepts

page 164

33. Consider the trajectory of the cannonball shown in **Figure 6-11**. (6.1)

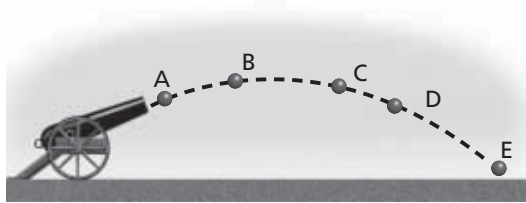

■ Figure 6-11

Up is positive, down is negative.

- a. Where is the magnitude of the vertical-velocity component largest?
The greatest vertical velocity occurs at point A.
- b. Where is the magnitude of the horizontal-velocity component largest?
Neglecting air resistance, the horizontal velocity at all points is the same. Horizontal velocity is constant and independent of vertical velocity.
- c. Where is the vertical-velocity smallest?
The least vertical velocity occurs at point E.
- d. Where is the magnitude of the acceleration smallest?
The magnitude of the acceleration is the same everywhere.
34. A student is playing with a radio-controlled race car on the balcony of a sixth-floor apartment. An accidental turn sends the car through the railing and over the edge of the balcony. Does the time it takes the car to fall depend upon the speed it had when it left the balcony? (6.1)
No, the horizontal component of motion does not affect the vertical component.
35. An airplane pilot flying at constant velocity and altitude drops a heavy crate. Ignoring air resistance, where will the plane be relative to the crate when the crate hits the ground? Draw the path of the crate as seen by an observer on the ground. (6.1)
The plane will be directly over the crate when the crate hits the ground. Both have the same horizontal velocity. The crate will look like it is moving horizontally while falling vertically to an observer on the ground.
36. Can you go around a curve with the following accelerations? Explain.
- a. zero acceleration
No, going around a curve causes a change in direction of velocity. Thus, the acceleration cannot be zero.
- b. constant acceleration (6.2)
No, the magnitude of the acceleration may be constant, but the direction of the acceleration changes.

Chapter 6 continued

37. To obtain uniform circular motion, how must the net force depend on the speed of the moving object? (6.2)

Circular motion results when the direction of the force is constantly perpendicular to the instantaneous velocity of the object.

38. If you whirl a yo-yo about your head in a horizontal circle, in what direction must a force act on the yo-yo? What exerts the force? (6.2)

The force is along the string toward the center of the circle that the yo-yo follows. The string exerts the force.

39. Why is it that a car traveling in the opposite direction as the car in which you are riding on the freeway often looks like it is moving faster than the speed limit? (6.3)

The magnitude of the relative velocity of that car to your car can be found by adding the magnitudes of the two cars' velocities together. Since each car probably is moving at close to the speed limit, the resulting relative velocity will be larger than the posted speed limit.

Applying Concepts

pages 164–165

40. **Projectile Motion** Analyze how horizontal motion can be uniform while vertical motion is accelerated. How will projectile motion be affected when drag due to air resistance is taken into consideration?

The horizontal motion is uniform because there are no forces acting in that direction (ignoring friction). The vertical motion is accelerated due to the force of gravity. The projectile motion equations in this book do not hold when friction is taken into account. Projectile motion in both directions will be impacted when drag due to air resistance is taken into consideration. There will be a friction force opposing the motion.

41. **Baseball** A batter hits a pop-up straight up over home plate at an initial velocity of 20 m/s. The ball is caught by the catcher at the same height that it was hit. At what velocity does the ball land in the catcher's mitt? Neglect air resistance.

–20 m/s, where the negative sign indicates down

42. **Fastball** In baseball, a fastball takes about $\frac{1}{2}$ s to reach the plate. Assuming that such a pitch is thrown horizontally, compare the distance the ball falls in the first $\frac{1}{4}$ s with the distance it falls in the second $\frac{1}{4}$ s.

Because of the acceleration due to gravity, the baseball falls a greater distance during the second $\frac{1}{4}$ s than during the first $\frac{1}{4}$ s.

43. You throw a rock horizontally. In a second horizontal throw, you throw the rock harder and give it even more speed.

- a. How will the time it takes the rock to hit the ground be affected? Ignore air resistance.

The time does not change—the time it takes to hit the ground depends only on vertical velocities and acceleration.

- b. How will the increased speed affect the distance from where the rock left your hand to where the rock hits the ground?

A higher horizontal speed produces a longer horizontal distance.

44. **Field Biology** A zoologist standing on a cliff aims a tranquilizer gun at a monkey hanging from a distant tree branch. The barrel of the gun is horizontal. Just as the zoologist pulls the trigger, the monkey lets go and begins to fall. Will the dart hit the monkey? Ignore air resistance.

Yes, in fact, the monkey would be safe if it did not let go of the branch. The vertical acceleration of the dart is the same as that of the monkey. Therefore, the dart is at the same vertical height when

Chapter 6 continued

it reaches the monkey.

- 45. Football** A quarterback throws a football at 24 m/s at a 45° angle. If it takes the ball 3.0 s to reach the top of its path and the ball is caught at the same height at which it is thrown, how long is it in the air? Ignore air resistance.

6.0 s: 3.0 s up and 3.0 s down

- 46. Track and Field** You are working on improving your performance in the long jump and believe that the information in this chapter can help. Does the height that you reach make any difference to your jump? What influences the length of your jump?

Both speed and angle of launch matter, so height does make a difference. Maximum range is achieved when the resultant velocity has equal vertical and horizontal components—in other words, a launch angle of 45° . For this reason, height and speed affect the range.

- 47.** Imagine that you are sitting in a car tossing a ball straight up into the air.

- a.** If the car is moving at a constant velocity, will the ball land in front of, behind, or in your hand?

The ball will land in your hand because you, the ball, and the car all are moving forward with the same speed.

- b.** If the car rounds a curve at a constant speed, where will the ball land?

The ball will land beside you, toward the outside of the curve. A top view would show the ball moving straight while you and the car moved out from under the ball.

- 48.** You swing one yo-yo around your head in a horizontal circle. Then you swing another yo-yo with twice the mass of the first one, but you don't change the length of the string or the period. How do the tensions in the strings differ?

The tension in the string is doubled since $F_T = ma_c$.

Chapter 6 continued

- 49. Car Racing** The curves on a race track are banked to make it easier for cars to go around the curves at high speeds. Draw a free-body diagram of a car on a banked curve. From the motion diagram, find the direction of the acceleration.

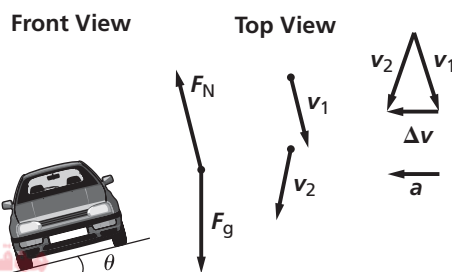

The acceleration is directed toward the center of the track.

- a. What exerts the force in the direction of the acceleration?

The component of the normal force acting toward the center of the curve, and depending on the car's speed, the component of the friction force acting toward the center, both contribute to the net force in the direction of acceleration.

- b. Can you have such a force without friction?

Yes, the centripetal acceleration need only be due to the normal force.

- 50. Driving on the Highway** Explain why it is that when you pass a car going in the same direction as you on the freeway, it takes a longer time than when you pass a car going in the opposite direction.

The relative speed of two cars going in the same direction is less than the relative speed of two cars going in the opposite direction. Passing with the lesser relative speed will take longer.

Mastering Problems

6.1 Projectile Motion

page 165

Level 1

- 51.** You accidentally throw your car keys horizontally at 8.0 m/s from a cliff 64-m high. How far from the base of the cliff

Physics: Principles and Problems

should you look for the keys?

$$y = v_{y0}t - \frac{1}{2}gt^2$$

Since initial vertical velocity is zero,

$$t = \sqrt{\frac{-2y}{g}} = \sqrt{\frac{(-2)(-64 \text{ m})}{9.80 \text{ m/s}^2}}$$

$$= 3.6 \text{ s}$$

$$x = v_x t = (8.0 \text{ m/s})(3.6) = 28.8 \text{ m}$$

$$= 29 \text{ m}$$

- 52.** The toy car in **Figure 6-12** runs off the edge of a table that is 1.225-m high. The car lands 0.400 m from the base of the table.

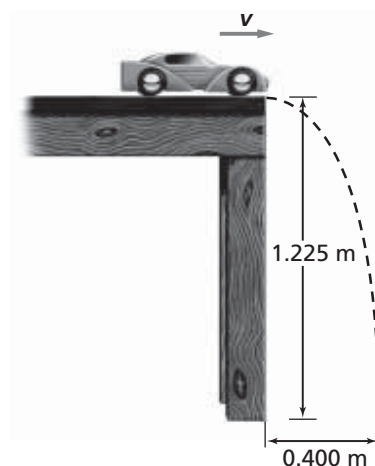

■ **Figure 6-12**

- a. How long did it take the car to fall?

$$y = v_{y0}t - \frac{1}{2}gt^2$$

Since initial vertical velocity is zero,

$$t = \sqrt{\frac{-2y}{g}} = \sqrt{\frac{(-2)(-1.225 \text{ m})}{9.80 \text{ m/s}^2}}$$

$$= 0.500 \text{ s}$$

- b. How fast was the car going on the table?

$$v_x = \frac{x}{t} = \frac{0.400 \text{ m}}{0.500 \text{ s}} = 0.800 \text{ m/s}$$

- 53.** A dart player throws a dart horizontally at 12.4 m/s. The dart hits the board 0.32 m below the height from which it was thrown. How far away is the player from the board?

$$y = v_{y0}t - \frac{1}{2}gt^2$$

and because initial velocity is zero,

$$t = \sqrt{\frac{-2y}{g}}$$

Chapter 6 continued

$$= \sqrt{\frac{(-2)(-0.32 \text{ m})}{9.80 \text{ m/s}^2}}$$

$$= 0.26 \text{ s}$$

Now $x = v_x t$

$$= (12.4 \text{ m/s})(0.26 \text{ s})$$

$$= 3.2 \text{ m}$$

54. The two baseballs in **Figure 6-13** were hit with the same speed, 25 m/s. Draw separate graphs of y versus t and x versus t for each ball.

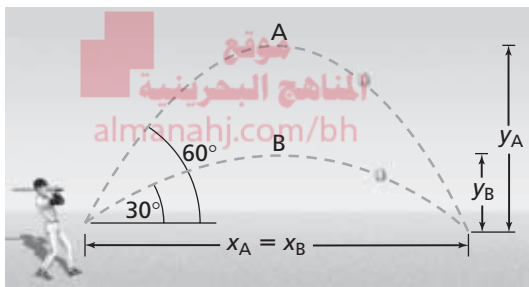

■ Figure 6-13

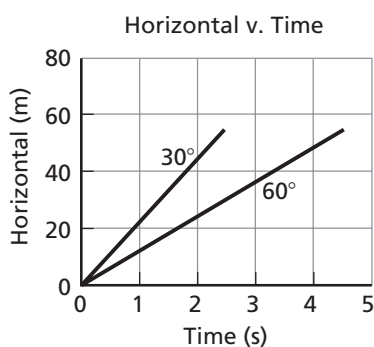
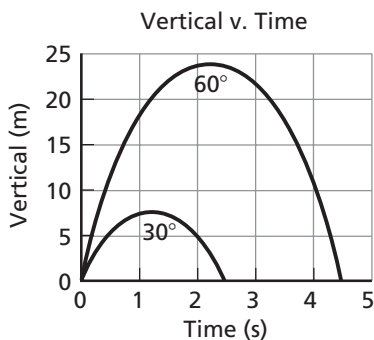

55. **Swimming** You took a running leap off a high-diving platform. You were running at 2.8 m/s and hit the water 2.6 s later. How high was the platform, and how far from the edge of the platform did you hit the water? Ignore air resistance.

$$y = v_{yi}t - \frac{1}{2}gt^2$$

$$= 0(2.6 \text{ s}) - \frac{1}{2}(9.80 \text{ m/s}^2)(2.6 \text{ s})^2$$

$$= -33 \text{ m, so the platform is 33 m high}$$

$$x = v_x t = (2.8 \text{ m/s})(2.6 \text{ s}) = 7.3 \text{ m}$$

Level 2

56. **Archery** An arrow is shot at 30.0° above the horizontal. Its velocity is 49 m/s, and it hits the target.

- a. What is the maximum height the arrow will attain?

$$v_y^2 = v_{yi}^2 - 2gd$$

At the high point $v_y = 0$, so

$$d = \frac{(v_{y0})^2}{2g}$$

$$= \frac{(v_i \sin \theta)^2}{2g}$$

$$= \frac{((49 \text{ m/s})(\sin 30.0^\circ))^2}{(2)(9.80 \text{ m/s}^2)}$$

$$= 31 \text{ m}$$

- b. The target is at the height from which the arrow was shot. How far away is it?

$$y = v_{y0}t - \frac{1}{2}gt^2$$

but the arrow lands at the same height, so

$$y = 0 \text{ and } 0 = v_{yi} - \frac{1}{2}gt$$

so $t = 0$ or

$$t = \frac{2v_{yi}}{g}$$

$$= \frac{2v_i \sin \theta}{g}$$

$$= \frac{(2)(49 \text{ m/s})(\sin 30.0^\circ)}{9.80 \text{ m/s}^2}$$

$$= 5.0 \text{ s}$$

Chapter 6 continued

$$\begin{aligned} \text{and } x &= v_x t \\ &= (v_i \cos \theta)(t) \\ &= (49 \text{ m/s})(\cos 30.0^\circ)(5.0 \text{ s}) \\ &= 2.1 \times 10^2 \text{ m} \end{aligned}$$

- 57. Hitting a Home Run** A pitched ball is hit by a batter at a 45° angle and just clears the outfield fence, 98 m away. If the fence is at the same height as the pitch, find the velocity of the ball when it left the bat. Ignore air resistance.

The components of the initial velocity are $v_x = v_i \cos \theta_i$ and $v_{yi} = v_i \sin \theta_i$

Now $x = v_x t = (v_i \cos \theta_i)t$, so

$$t = \frac{x}{v_i \cos \theta_i}$$

And $y = v_{yi}t - \frac{1}{2}gt^2$, but $y = 0$, so

$$0 = (v_{yi} - \frac{1}{2}gt)t$$

$$\text{so } t = 0 \text{ or } v_{yi} - \frac{1}{2}gt = 0$$

From above

$$v_i \sin \theta_i - \frac{1}{2}g\left(\frac{x}{v_i \cos \theta_i}\right) = 0$$

Multiplying by $v_i \cos \theta_i$ gives

$$v_i^2 \sin \theta_i \cos \theta_i - \frac{1}{2}gx = 0$$

$$\text{so } v_i^2 = \frac{gx}{(2)(\sin \theta_i)(\cos \theta_i)}$$

$$\begin{aligned} \text{thus, } v_i &= \sqrt{\frac{gx}{(2)(\sin \theta_i)(\cos \theta_i)}} \\ &= \sqrt{\frac{(9.80 \text{ m/s}^2)(98 \text{ m})}{(2)(\sin 45^\circ)(\cos 45^\circ)}} \\ &= 31 \text{ m/s at } 45^\circ \end{aligned}$$

Level 3

- 58. At-Sea Rescue** An airplane traveling 1001 m above the ocean at 125 km/h is going to drop a box of supplies to shipwrecked victims below.

- a. How many seconds before the plane is directly overhead should the box be dropped?

$$y = v_{yi}t - \frac{1}{2}gt^2$$

but $v_{yi} = 0$, so

$$\begin{aligned} t &= \sqrt{\frac{-2y}{g}} \\ &= \sqrt{\frac{(-2)(-1001 \text{ m})}{9.80 \text{ m/s}^2}} \\ &= 14.3 \text{ s} \end{aligned}$$

- b. What is the horizontal distance between the plane and the victims when the box is dropped?

$$\begin{aligned} x &= v_x t \\ &= (125 \text{ km/h})\left(\frac{1 \text{ h}}{3600 \text{ s}}\right)\left(\frac{1000 \text{ m}}{1 \text{ km}}\right) \\ &\quad (14.3 \text{ s}) \\ &= 497 \text{ m} \end{aligned}$$

- 59. Diving** Divers in Acapulco dive from a cliff that is 61 m high. If the rocks below the cliff extend outward for 23 m, what is the minimum horizontal velocity a diver must have to clear the rocks?

$$y = v_{yi}t - \frac{1}{2}gt^2$$

and since $v_{yi} = 0$,

$$\begin{aligned} t &= \sqrt{\frac{-2y}{g}} \\ &= \sqrt{\frac{(-2)(-61 \text{ m})}{9.80 \text{ m/s}^2}} \\ &= 3.53 \text{ s} \end{aligned}$$

$$x = v_x t$$

$$\begin{aligned} v_x &= \frac{x}{t} \\ &= \frac{23 \text{ m}}{3.53 \text{ s}} \\ &= 6.5 \text{ m/s} \end{aligned}$$

- 60. Jump Shot** A basketball player is trying to make a half-court jump shot and releases the ball at the height of the basket. Assuming that the ball is launched at 51.0° , 14.0 m from the basket, what speed must the player give the ball?

The components of the initial velocity are $v_{xi} = v_i \cos \theta_i$ and $v_{yi} = v_i \sin \theta_i$

Now $x = v_{xi}t = (v_i \cos \theta_i)t$, so



$$t = \frac{x}{v_i \cos \theta_i}$$

And $y = v_{yi}t - \frac{1}{2}gt^2$, but $y = 0$, so

$$0 = \left(v_{yi} - \frac{1}{2}gt\right)t$$

$$\text{so } t = 0 \text{ or } v_{yi} - \frac{1}{2}gt = 0$$

From above

$$v_0 \sin \theta_i - \frac{1}{2}g\left(\frac{x}{v_i \cos \theta_i}\right) = 0$$

Multiplying by $v_i \cos \theta_i$ gives

$$v_i^2(\sin \theta_i)(\cos \theta_i) - \frac{1}{2}gx = 0$$

$$\begin{aligned} \text{so } v_i &= \sqrt{\frac{gx}{(2)(\sin \theta_i)(\cos \theta_i)}} \\ &= \sqrt{\frac{(9.80 \text{ m/s}^2)(14.0 \text{ m})}{(2)(\sin 51.0^\circ)(\cos 51.0^\circ)}} \\ &= 11.8 \text{ m/s} \end{aligned}$$

6.2 Circular Motion

page 166

Level 1

61. Car Racing A 615-kg racing car completes one lap in 14.3 s around a circular track with a radius of 50.0 m. The car moves at a constant speed.

a. What is the acceleration of the car?

$$\begin{aligned} a_c &= \frac{v^2}{r} \\ &= \frac{4\pi^2 r}{T^2} \\ &= \frac{4\pi^2(50.0 \text{ m})}{(14.3 \text{ s})^2} \\ &= 9.59 \text{ m/s}^2 \end{aligned}$$

b. What force must the track exert on the tires to produce this acceleration?

$$\begin{aligned} F_c &= ma_c = (615 \text{ kg})(9.59 \text{ m/s}^2) \\ &= 5.90 \times 10^3 \text{ N} \end{aligned}$$

Chapter 6 continued

- 62. Hammer Throw** An athlete whirls a 7.00-kg hammer 1.8 m from the axis of rotation in a horizontal circle, as shown in **Figure 6-14**. If the hammer makes one revolution in 1.0 s, what is the centripetal acceleration of the hammer? What is the tension in the chain?



■ Figure 6-14

$$\begin{aligned}
 a_c &= \frac{4\pi^2 r}{T^2} \\
 &= \frac{(4\pi^2)(1.8 \text{ m})}{(1.0 \text{ s})^2} \\
 &= 71 \text{ m/s}^2 \\
 F_c &= ma_c \\
 &= (7.00 \text{ kg})(71 \text{ m/s}^2) \\
 &= 5.0 \times 10^2 \text{ N}
 \end{aligned}$$

Level 2

- 63.** A coin is placed on a vinyl stereo record that is making $33\frac{1}{3}$ revolutions per minute on a turntable.

- a.** In what direction is the acceleration of the coin?

The acceleration is toward the center of the record.

- b.** Find the magnitude of the acceleration when the coin is placed 5.0, 10.0, and 15.0 cm from the center of the record.

$$\begin{aligned}
 T &= \frac{1}{f} = \frac{1}{33\frac{1}{3} \text{ rev/min}} \\
 &= (0.0300 \text{ min}) \left(\frac{60 \text{ s}}{1 \text{ min}} \right) = 1.80 \text{ s}
 \end{aligned}$$

$r = 5.0 \text{ cm:}$

$$a_c = \frac{4\pi^2 r}{T^2}$$

$$= \frac{(4\pi^2)(0.050 \text{ m})}{(1.80 \text{ s})^2} = 0.61 \text{ m/s}^2$$

$r = 10.0 \text{ cm:}$

$$a_c = \frac{4\pi^2 r}{T^2} = \frac{(4\pi^2)(0.100 \text{ m})}{(1.80 \text{ s})^2}$$

$$= 1.22 \text{ m/s}^2$$

$r = 15.0 \text{ cm:}$

$$a_c = \frac{4\pi^2 r}{T^2} = \frac{(4\pi^2)(0.150 \text{ m})}{(1.80 \text{ s})^2}$$

$$= 1.83 \text{ m/s}^2$$

- c.** What force accelerates the coin?
frictional force between coin and record
- d.** At which of the three radii in part **b** would the coin be most likely to fly off the turntable? Why?

15.0 cm, the largest radius; the friction force needed to hold it is the greatest.

- 64.** A rotating rod that is 15.3 cm long is spun with its axis through one end of the rod so that the other end of the rod has a speed of 2010 m/s (4500 mph).

- a.** What is the centripetal acceleration of the end of the rod?

$$\begin{aligned}
 a_c &= \frac{v^2}{r} = \frac{(2010 \text{ m/s})^2}{0.153 \text{ m}} \\
 &= 2.64 \times 10^7 \text{ m/s}^2
 \end{aligned}$$

- b.** If you were to attach a 1.0-g object to the end of the rod, what force would be needed to hold it on the rod?

$$\begin{aligned}
 F_c &= ma_c \\
 &= (0.0010 \text{ kg})(2.64 \times 10^7 \text{ m/s}^2) \\
 &= 2.6 \times 10^4 \text{ N}
 \end{aligned}$$

- 65.** Friction provides the force needed for a car to travel around a flat, circular race track. What is the maximum speed at which a car can safely travel if the radius of the track is 80.0 m and the coefficient of friction is 0.40?

$$F_c = F_f = \mu F_N = \mu mg$$

$$\text{But } F_c = \frac{mv^2}{r}, \text{ thus } \frac{mv^2}{r} = \mu mg.$$

Chapter 6 continued

The mass of the car divides out to give

$$v^2 = \mu gr, \text{ so}$$

$$v = \sqrt{\mu gr}$$

$$= \sqrt{(0.40)(9.80 \text{ m/s}^2)(80.0 \text{ m})}$$

$$= 18 \text{ m/s}$$

Level 3

66. A carnival clown rides a motorcycle down a ramp and around a vertical loop. If the loop has a radius of 18 m, what is the slowest speed the rider can have at the top of the loop to avoid falling? *Hint: At this slowest speed, the track exerts no force on the motorcycle at the top of the loop.*

$$F_c = ma_c = F_g = mg, \text{ so}$$

$$a_c = g$$

$$\frac{v^2}{r} = g, \text{ so}$$

$$v = \sqrt{gr}$$

$$= \sqrt{(9.80 \text{ m/s}^2)(18 \text{ m})}$$

$$= 13 \text{ m/s}$$

67. A 75-kg pilot flies a plane in a loop as shown in **Figure 6-15**. At the top of the loop, when the plane is completely upside-down for an instant, the pilot hangs freely in the seat and does not push against the seat belt. The airspeed indicator reads 120 m/s. What is the radius of the plane's loop?

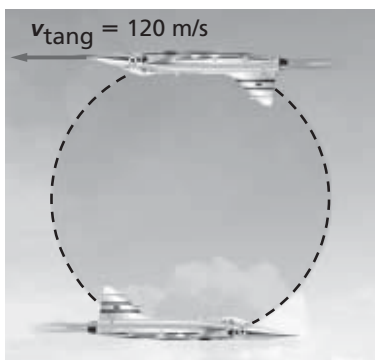

■ Figure 6-15

Because the net force is equal to the weight of the pilot,

$$F_c = ma_c = F_g = mg, \text{ so}$$

$$a_c = g \text{ or } \frac{v^2}{r} = g$$

$$\text{so } r = \frac{v^2}{g}$$

$$= \frac{(120 \text{ m/s})^2}{9.80 \text{ m/s}^2}$$

$$= 1.5 \times 10^3 \text{ m}$$

6.3 Relative Velocity

pages 166–167

Level 1

68. **Navigating an Airplane** An airplane flies at 200.0 km/h relative to the air. What is the velocity of the plane relative to the ground if it flies during the following wind conditions?

- a. a 50.0-km/h tailwind

Tailwind is in the same direction as the airplane

$$200.0 \text{ km/h} + 50.0 \text{ km/h} = 250.0 \text{ km/h}$$

- b. a 50.0-km/h headwind

Head wind is in the opposite direction of the airplane

$$200.0 \text{ km/h} - 50.0 \text{ km/h} = 150.0 \text{ km/h}$$

69. Odina and LaToya are sitting by a river and decide to have a race. Odina will run down the shore to a dock, 1.5 km away, then turn around and run back. LaToya will also race to the dock and back, but she will row a boat in the river, which has a current of 2.0 m/s. If Odina's running speed is equal to LaToya's rowing speed in still water, which is 4.0 m/s, who will win the race? Assume that they both turn instantaneously.

$$x = vt, \text{ so } t = \frac{x}{v}$$

for Odina,

$$t = \frac{3.0 \times 10^3 \text{ m}}{4.0 \text{ m/s}}$$

$$= 7.5 \times 10^2 \text{ s}$$

For LaToya (assume against current on the way to the dock),

$$t = \frac{x_1}{v_1} + \frac{x_2}{v_2}$$

Chapter 6 continued

$$= \frac{1.5 \times 10^3 \text{ m}}{4.0 \text{ m/s} - 2.0 \text{ m/s}} + \frac{1.5 \times 10^3 \text{ m}}{4.0 \text{ m/s} + 2.0 \text{ m/s}}$$

$$= 1.0 \times 10^3 \text{ s}$$

Odina wins.

Level 2

- 70. Crossing a River** You row a boat, such as the one in **Figure 6-16**, perpendicular to the shore of a river that flows at 3.0 m/s. The velocity of your boat is 4.0 m/s relative to the water.



■ **Figure 6-16**

- a. What is the velocity of your boat relative to the shore?

$$v_{b/s} = \sqrt{(v_{b/w})^2 + (v_{w/s})^2}$$

$$= \sqrt{(4.0 \text{ m/s})^2 + (3.0 \text{ m/s})^2}$$

$$= 5.0 \text{ m/s}$$

$$\theta = \tan^{-1}\left(\frac{v_{b/w}}{v_{w/s}}\right)$$

$$= \tan^{-1}\left(\frac{4.0 \text{ m/s}}{3.0 \text{ m/s}}\right)$$

$$= 53^\circ \text{ from shore}$$

- b. What is the component of your velocity parallel to the shore? Perpendicular to it?

3.0 m/s; 4.0 m/s

- 71. Studying the Weather** A weather station releases a balloon to measure cloud conditions that rises at a constant 15 m/s relative to the air, but there is also a wind blowing at 6.5 m/s toward the west. What are the magnitude and direction of the velocity of the balloon?

$$v_b = \sqrt{(v_{b/air})^2 + (v_{air})^2}$$

$$= \sqrt{(15 \text{ m/s})^2 + (6.5 \text{ m/s})^2}$$

$$= 16 \text{ m/s}$$

$$\theta = \tan^{-1}\left(\frac{v_{b/air}}{v_{air}}\right)$$

$$= \tan^{-1}\left(\frac{15 \text{ m/s}}{6.5 \text{ m/s}}\right)$$

= 67° from the horizon toward the west

Level 3

- 72. Boating** You are boating on a river that flows toward the east. Because of your knowledge of physics, you head your boat 53° west of north and have a velocity of 6.0 m/s due north relative to the shore.

- a. What is the velocity of the current?

$$\tan \theta = \left(\frac{v_{w/s}}{v_{b/s}}\right), \text{ so}$$

$$v_{w/s} = (\tan \theta)(v_{b/s})$$

$$= (\tan 53^\circ)(6.0 \text{ m/s})$$

$$= 8.0 \text{ m/s east}$$

- b. What is the speed of your boat relative to the water?

$$\cos \theta = \frac{v_{b/s}}{v_{b/w}}, \text{ so}$$

$$v_{b/w} = \frac{v_{b/s}}{\cos \theta}$$

$$= \frac{6.0 \text{ m/s}}{\cos 53^\circ}$$

$$= 1.0 \times 10^1 \text{ m/s}$$

- 73. Air Travel** You are piloting a small plane, and you want to reach an airport 450 km due south in 3.0 h. A wind is blowing from the west at 50.0 km/h. What heading and airspeed should you choose to reach your destination in time?

$$v_s = \frac{d_s}{t} = \frac{450 \text{ km}}{3.0 \text{ h}} = 150 \text{ km/h}$$

$$v_p = \sqrt{(150 \text{ km/h})^2 + (50.0 \text{ km/h})^2}$$

$$= 1.6 \times 10^2 \text{ km/h}$$

$$\theta = \tan^{-1}\left(\frac{v_{\text{wind}}}{v_s}\right)$$

$$= \tan^{-1}\left(\frac{50.0 \text{ km/h}}{150 \text{ km/h}}\right)$$

$$= 18^\circ \text{ west of south}$$

Mixed Review

Chapter 6 continued

page 167

Level 1

74. Early skeptics of the idea of a rotating Earth said that the fast spin of Earth would throw people at the equator into space. The radius of Earth is about 6.38×10^3 km. Show why this idea is wrong by calculating the following.

a. the speed of a 97-kg person at the equator

$$v = \frac{\Delta d}{\Delta t} = \frac{2\pi r}{T} = \frac{2\pi(6.38 \times 10^6 \text{ m})}{(24 \text{ h})\left(\frac{3600 \text{ s}}{1 \text{ h}}\right)}$$
$$= 464 \text{ m/s}$$

b. the force needed to accelerate the person in the circle

$$F_c = ma_c$$

$$= \frac{mv^2}{r}$$

$$= \frac{(97 \text{ kg})(464 \text{ m/s})^2}{6.38 \times 10^6 \text{ m}}$$

$$= 3.3 \text{ N}$$

c. the weight of the person

$$F_g = mg$$

$$= (97)(9.80 \text{ m/s}^2)$$

$$= 9.5 \times 10^2 \text{ N}$$

d. the normal force of Earth on the person, that is, the person's apparent weight

$$F_N = 9.5 \times 10^2 \text{ N} - 3.3 \text{ N}$$

$$= 9.5 \times 10^2 \text{ N}$$

75. Firing a Missile An airplane, moving at 375 m/s relative to the ground, fires a missile forward at a speed of 782 m/s relative to the plane. What is the speed of the missile relative to the ground?

$$v_{m/g} = v_{p/g} + v_{m/p}$$

$$= 375 \text{ m/s} + 782 \text{ m/s}$$

$$= 1157 \text{ m/s}$$

76. Rocketry A rocket in outer space that is moving at a speed of 1.25 km/s relative to an observer fires its motor. Hot gases are expelled out the back at 2.75 km/s relative to the rocket. What is the speed of the gases relative to the observer?

$$v_{g/o} = v_{r/o} + v_{g/r}$$

$$1.25 \text{ km/s} + (-2.75 \text{ km/s}) = -1.50 \text{ km/s}$$

Level 2

77. Two dogs, initially separated by 500.0 m, are running towards each other, each moving with a constant speed of 2.5 m/s. A dragonfly, moving with a constant speed of 3.0 m/s, flies from the nose of one dog to the other, then turns around

Chapter 6 continued

instantaneously and flies back to the other dog. It continues to fly back and forth until the dogs run into each other. What distance does the dragonfly fly during this time?

The dogs will meet in

$$\frac{500.0 \text{ m}}{5.0 \text{ m/s}} = 1.0 \times 10^2 \text{ s}$$

The dragonfly flies

$$(3.0 \text{ m/s})(1.0 \times 10^2 \text{ s}) = 3.0 \times 10^2 \text{ m.}$$

- 78.** A 1.13-kg ball is swung vertically from a 0.50-m cord in uniform circular motion at a speed of 2.4 m/s. What is the tension in the cord at the bottom of the ball's motion?

$$F_T = F_g + F_c$$

$$= mg + \frac{mv^2}{r}$$

$$= (1.13 \text{ kg})(9.80 \text{ m/s}^2) +$$

$$\frac{(1.13 \text{ kg})(2.4 \text{ m/s})^2}{0.50 \text{ m}}$$

$$= 24 \text{ N}$$

- 79. Banked Roads** Curves on roads often are banked to help prevent cars from slipping off the road. If the posted speed limit for a particular curve of radius 36.0 m is 15.7 m/s (35 mph), at what angle should the road be banked so that cars will stay on a circular path even if there were no friction between the road and the tires? If the speed limit was increased to 20.1 m/s (45 mph), at what angle should the road be banked?

For 35 mph:

$$F_c = F_g$$

$$\frac{mv^2}{r} \cos \theta = mg \sin \theta$$

$$\frac{v^2}{r} = g \left(\frac{\sin \theta}{\cos \theta} \right) = g \tan \theta$$

$$\theta = \tan^{-1} \left(\frac{v^2}{gr} \right)$$

$$= \tan^{-1} \left(\frac{(15.7 \text{ m/s})^2}{(9.80 \text{ m/s}^2)(56.0 \text{ m})} \right)$$

$$= 34.9^\circ$$

For 45 mph:

$$\theta = \tan^{-1} \left(\frac{v^2}{gr} \right)$$

$$= \tan^{-1} \left(\frac{(20.1 \text{ m/s})^2}{(9.80 \text{ m/s}^2)(36.0 \text{ m})} \right)$$

$$= 48.9^\circ$$

Level 3

- 80.** The 1.45-kg ball in **Figure 6-17** is

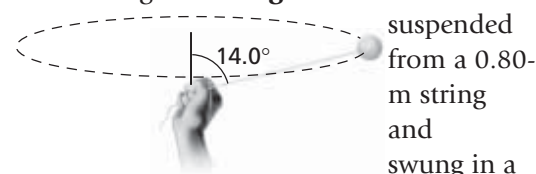

■ **Figure 6-17** horizontal

circle at a constant speed such that the string makes an angle of 14.0° with the vertical.

- a.** What is the tension in the string?

$$F_T \cos \theta = mg$$

$$\text{so } F_T = \frac{mg}{\cos \theta}$$

$$= \frac{(1.45 \text{ m/s})(9.80 \text{ m/s}^2)}{\cos 14.0^\circ}$$

$$= 14.6 \text{ N}$$

- b.** What is the speed of the ball?

$$F_c = F_T \sin \theta = \frac{mv^2}{r} = F_g = F_T \cos \theta$$

$$\theta = mg$$

$$\text{so } \frac{F_T \sin \theta}{F_T \cos \theta} = \frac{mv^2}{rmg}$$

$$\text{or } \tan \theta = \frac{v^2}{rg}$$

Chapter 6 continued

$$\begin{aligned} \text{so } v &= \sqrt{rg \tan \theta} \\ &= \sqrt{(0.80 \text{ m})(9.80 \text{ m/s}^2)(\tan 14.0^\circ)} \\ &= 1.4 \text{ m/s} \end{aligned}$$

- 81.** A baseball is hit directly in line with an outfielder at an angle of 35.0° above the horizontal with an initial velocity of 22.0 m/s. The outfielder starts running as soon as the ball is hit at a constant velocity of 2.5 m/s and barely catches the ball. Assuming that the ball is caught at the same height at which it was hit, what was the initial separation between the hitter and outfielder? *Hint: There are two possible answers.*

$$\Delta x = v_{xi}t \pm v_p t = t(v_{xi} \pm v_p)$$

To get t ,

$$y = v_{yi}t - \frac{1}{2}gt^2, y = 0$$

$$\text{so } v_{yi}t = \frac{1}{2}gt^2, t = 0 \text{ or}$$

$$v_{yi} = \frac{1}{2}gt$$

$$t = \frac{2v_{yi}}{g}$$

$$= \frac{2v_i \sin \theta}{g}$$

$$\begin{aligned} \text{so } \Delta x &= \frac{2v_i \sin \theta}{g}(v_{xi} \pm v_p) \\ &= \frac{2v_i \sin \theta}{g}(v_i \cos \theta \pm v_p) \\ &= \left(\frac{(2)(22.0 \text{ m/s})(\sin 35.0^\circ)}{9.80 \text{ m/s}^2} \right) \\ &\quad ((22.0 \text{ m/s})(\cos 35.0^\circ) \pm \\ &\quad 2.5 \text{ m/s}) \\ &= 53 \text{ m or } 4.0 \times 10^1 \text{ m} \end{aligned}$$

- 82. A Jewel Heist** You are serving as a technical consultant for a locally produced cartoon. In one episode, two criminals, Shifty and Lefty, have stolen some jewels. Lefty has the jewels when the police start to chase him, and he runs to the top of a 60.0-m tall building in his attempt to escape. Meanwhile, Shifty runs to the convenient hot-air balloon 20.0 m from the base of the building and untethers it, so it begins to rise at a constant speed. Lefty tosses the bag of jewels horizontally with a speed of 7.3 m/s just as the balloon

Chapter 6 continued

begins its ascent. What must the velocity of the balloon be for Shifty to easily catch the bag?

$$\Delta x = v_{xi}t, \text{ so } t = \frac{x}{v_{xi}}$$

$$\Delta y_{\text{bag}} = v_{yi}t - \frac{1}{2}gt^2, \text{ but } v_{yi} = 0$$

$$\text{so } \Delta y_{\text{bag}} = -\frac{1}{2}gt^2$$

$$\begin{aligned} v_{\text{balloon}} &= \frac{\Delta y_{\text{balloon}}}{t} \\ &= \frac{60.0 \text{ m} - \Delta y_{\text{bag}}}{t} \\ &= \frac{60.0 \text{ m} + \frac{1}{2}gt^2}{t} \\ &= \frac{60.0 \text{ m}}{t} + \frac{1}{2}gt \\ &= \frac{60.0 \text{ m}}{\frac{x}{v_{xi}}} + \frac{1}{2}g \frac{x}{v_{xi}} \\ &= \frac{(60.0 \text{ m})v_{xi}}{x} + \frac{gx}{2v_{xi}} \\ &= \frac{(60.0 \text{ m})(7.3 \text{ m/s})}{(20.0 \text{ m})} + \\ &\quad \frac{(-9.80 \text{ m/s})(20.0 \text{ m})}{2(7.3 \text{ m/s})} \\ &= 8.5 \text{ m/s} \end{aligned}$$

Thinking Critically

page 168

83. Apply Concepts Consider a roller-coaster loop like the one in **Figure 6-18**. Are the cars traveling through the loop in uniform circular motion? Explain.



■ Figure 6-18

The vertical gravitational force changes the speed of the cars, so the motion is not uniform circular motion.

84. Use Numbers A 3-point jump shot is released 2.2 m above the ground and 6.02 m from the basket. The basket is 3.05 m above the floor. For launch angles of 30.0° and 60.0°, find the speed the ball needs to be thrown to make the basket.

Chapter 6 continued

$$x = v_{ix}t, \text{ so } t = \frac{x}{v_{ix}} = \frac{x}{v_i \cos \theta}$$

$$\begin{aligned} \Delta y &= v_{iy}t - \frac{1}{2}gt^2 \\ &= v_i \sin \theta \left(\frac{x}{v_i \cos \theta} \right) - \frac{1}{2}g \left(\frac{x}{v_i \cos \theta} \right)^2 \\ &= x \tan \theta - \frac{gx^2}{2v_i^2(\cos \theta)^2} \end{aligned}$$

$$\text{so } v_i = \frac{x}{\cos \theta} \sqrt{\frac{g}{2((\tan \theta)x - \Delta y)}}$$

For $\theta = 30.0^\circ$

$$v_i = \frac{6.02}{\cos 30.0^\circ} \sqrt{\frac{9.80 \text{ m/s}^2}{2((\tan 30.0^\circ)(6.02 \text{ m}) - (3.05 \text{ m} - 2.2 \text{ m}))}}$$

= 9.5 m/s

For $\theta = 60.0^\circ$

$$v_i = \frac{6.02}{\cos 60.0^\circ} \sqrt{\frac{-9.80 \text{ m/s}^2}{2((\tan 60.0^\circ)(6.02 \text{ m}) - (3.05 \text{ m} - 2.2 \text{ m}))}}$$

= 8.6 m/s

- 85. Analyze** For which angle in problem 84 is it more important that the player get the speed right? To explore this question, vary the speed at each angle by 5 percent and find the change in the range of the attempted shot.

Varying speed by 5 percent at 30.0° changes R by about 0.90 m in either direction. At 60.0° it changes R by only about 0.65 m. Thus, the high launch angle is less sensitive to speed variations.

- 86. Apply Computers and Calculators** A baseball player hits a belt-high (1.0 m) fastball down the left-field line. The ball is hit with an initial velocity of 42.0 m/s at 26° . The left-field wall is 96.0 m from home plate at the foul pole and is 14-m high. Write the equation for the height of the ball, y , as a function of its distance from home plate, x . Use a computer or graphing calculator to plot the path of the ball. Trace along the path to find how high above the ground the ball is when it is at the wall.

- a. Is the hit a home run?
Yes, the hit is a home run; the ball clears the wall by 2.1 m.
- b. What is the minimum speed at which the ball could be hit and clear the wall?

$$v_i = \frac{x}{\cos \theta} \sqrt{\frac{g}{2((\tan \theta)x - \Delta y)}}$$

$$v_i = \frac{96.0 \text{ m}}{\cos 26^\circ} \sqrt{\frac{9.80 \text{ m/s}^2}{2((\tan 26^\circ)(96.0 \text{ m}) - 13 \text{ m})}}$$

= 41 m/s

- c. If the initial velocity of the ball is 42.0 m/s, for what range of angles will the ball go over the wall?
For the ball to go over the wall, the range of angles needs to be $25^\circ - 70^\circ$.

- 87. Analyze** Albert Einstein showed that the rule you learned for the addition of velocities does not work for objects moving near the speed of light. For example, if a rocket moving at velocity v_A releases a missile that has velocity v_B relative to the rocket, then the velocity of the missile relative to an observer that is at rest is given by $v = (v_A + v_B)/(1 + v_A v_B/c^2)$, where c is the speed of light, 3.00×10^8 m/s. This formula gives the correct values for objects moving at slow speeds as well. Suppose a rocket moving at 11 km/s shoots a laser beam out in front of it. What speed would an unmoving observer find for the laser light? Suppose that a rocket moves at a speed $c/2$, half the speed of light, and shoots a missile forward at a speed of $c/2$ relative to the rocket. How fast would the missile be moving relative to a fixed observer?

$$v_{l/o} = \frac{v_{r/o} + v_{l/r}}{1 + \frac{v_{r/o} v_{l/r}}{c^2}}$$

$$= \frac{1.1 \times 10^4 \text{ m/s} + 3.00 \times 10^8 \text{ m/s}}{1 + \frac{(1.1 \times 10^4 \text{ m/s})(3.00 \times 10^8 \text{ m/s})}{(3.00 \times 10^8 \text{ m/s})^2}}$$

= 3.0×10^8 m/s

$$v_{m/o} = \frac{v_{r/o} + v_{m/r}}{1 + \frac{v_{r/o} v_{m/r}}{c^2}}$$

Chapter 6 continued

$$\begin{aligned} &= \frac{\frac{c}{2} + \frac{c}{2}}{1 + \frac{\left(\frac{c}{2}\right)\left(\frac{c}{2}\right)}{c^2}} \\ &= \frac{4}{5}c \end{aligned}$$

- 88. Analyze and Conclude** A ball on a light string moves in a vertical circle. Analyze and describe the motion of this system. Be sure to consider the effects of gravity and tension. Is this system in uniform circular motion? Explain your answer.

It is not uniform circular motion.

Gravity increases the speed of the ball when it moves downward and reduces the speed when it is moving upward.

Therefore, the centripetal acceleration needed to keep it moving in a circle will be larger at the bottom and smaller at the top of the circle. At the top, tension and gravity are in the same direction, so the tension needed will be even smaller. At the bottom, gravity

is outward while the tension is inward. Thus, the tension exerted by the string must be even larger.

Writing in Physics

page 168

- 89. Roller Coasters** If you take a look at vertical loops on roller coasters, you will notice that most of them are not circular in shape. Research why this is so and explain the physics behind this decision by the coaster engineers.

Answers will vary. Since $F_c = \frac{mv^2}{r}$, as v decreases due to gravity when going uphill, r is reduced to keep the force constant.

- 90.** Many amusement-park rides utilize centripetal acceleration to create thrills for the park's customers. Choose two rides other than roller coasters that involve circular motion and explain how the physics of circular motion creates the sensations for the riders.

Practice Problems

7.1 Planetary Motion and Gravitation
pages 171–178

page 174

1. If Ganymede, one of Jupiter's moons, has a period of 32 days, how many units are there in its orbital radius? Use the information given in Example Problem 1.

$$\left(\frac{T_G}{T_J}\right)^2 = \left(\frac{r_G}{r_J}\right)^3$$

$$r_G = \sqrt[3]{(4.2 \text{ units})^3 \left(\frac{32 \text{ days}}{1.8 \text{ days}}\right)^2}$$

$$= \sqrt[3]{23.4 \times 10^3 \text{ units}^3}$$

$$= 29 \text{ units}$$

2. An asteroid revolves around the Sun with a mean orbital radius twice that of Earth's. Predict the period of the asteroid in Earth years.

$$\left(\frac{T_a}{T_E}\right)^2 = \left(\frac{r_a}{r_E}\right)^3 \text{ with } r_a = 2r_E$$

$$T_a = \sqrt{\left(\frac{r_a}{r_E}\right)^3 T_E^2}$$

$$= \sqrt{\left(\frac{2r_E}{r_E}\right)^3 (1.0 \text{ y})^2}$$

$$= 2.8 \text{ y}$$

3. From Table 7-1, on page 173, you can find that, on average, Mars is 1.52 times as far from the Sun as Earth is. Predict the time required for Mars to orbit the Sun in Earth days.

$$\left(\frac{T_M}{T_E}\right)^2 = \left(\frac{r_M}{r_E}\right)^3 \text{ with } r_M = 1.52r_E$$

$$\text{Thus, } T_M = \sqrt{\left(\frac{r_M}{r_E}\right)^3 T_E^2} = \sqrt{\left(\frac{1.52r_E}{r_E}\right)^3 (365 \text{ days})^2}$$

$$= \sqrt{4.68 \times 10^5 \text{ days}^2}$$

$$= 684 \text{ days}$$

4. The Moon has a period of 27.3 days and a mean distance of 3.90×10^5 km from the center of Earth.

- a. Use Kepler's laws to find the period of a satellite in orbit 6.70×10^3 km from the center of Earth.

$$\left(\frac{T_s}{T_M}\right)^2 = \left(\frac{r_s}{r_M}\right)^3$$

Chapter 7 continued

$$\begin{aligned}
 T_s &= \sqrt{\left(\frac{r_s}{r_M}\right)^3 T_M^2} \\
 &= \sqrt{\left(\frac{6.70 \times 10^3 \text{ km}}{3.90 \times 10^5 \text{ km}}\right)^3 (27.3 \text{ days})^2} \\
 &= \sqrt{3.78 \times 10^{-3} \text{ days}^2} \\
 &= 6.15 \times 10^{-2} \text{ days} = 88.6 \text{ min}
 \end{aligned}$$

- b. How far above Earth's surface is this satellite?

$$\begin{aligned}
 h &= r_s - r_E \\
 &= 6.70 \times 10^6 \text{ m} - 6.38 \times 10^6 \text{ m} \\
 &= 3.2 \times 10^5 \text{ m} \\
 &= 3.2 \times 10^2 \text{ km}
 \end{aligned}$$

موقع
المنهج البحرينية
almanabj.com

5. Using the data in the previous problem for the period and radius of revolution of the Moon, predict what the mean distance from Earth's center would be for an artificial satellite that has a period of exactly 1.00 day.

$$\begin{aligned}
 \left(\frac{T_s}{T_M}\right)^2 &= \left(\frac{r_s}{r_M}\right)^3 \\
 r_s &= \sqrt[3]{r_M^3 \left(\frac{T_s}{T_M}\right)^2} = \sqrt[3]{(3.90 \times 10^5 \text{ km})^3 \left(\frac{1.00 \text{ days}}{27.3 \text{ days}}\right)^2} \\
 &= \sqrt[3]{7.96 \times 10^{13} \text{ km}^3} \\
 &= 4.30 \times 10^4 \text{ km}
 \end{aligned}$$

Section Review

7.1 Planetary Motion and Gravitation pages 171–178

page 178

6. **Neptune's Orbital Period** Neptune orbits the Sun with an orbital radius of 4.495×10^{12} m, which allows gases, such as methane, to condense and form an atmosphere, as shown in **Figure 7-8**. If the mass of the Sun is 1.99×10^{30} kg, calculate the period of Neptune's orbit.

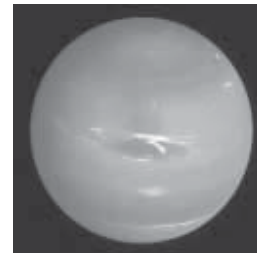

■ Figure 7-8

$$\begin{aligned}
 T &= 2\pi \sqrt{\frac{r^3}{Gm_S}} \\
 &= 2\pi \sqrt{\frac{(4.495 \times 10^{12} \text{ m})^3}{(6.67 \times 10^{-11} \text{ N}\cdot\text{m}^2/\text{kg}^2)(1.99 \times 10^{30} \text{ kg})}} \\
 &= 5.20 \times 10^9 \text{ s} = 6.02 \times 10^5 \text{ days}
 \end{aligned}$$

7. **Gravity** If Earth began to shrink, but its mass remained the same, what would happen to the value of g on Earth's surface?

The value of g would increase.

Chapter 7 continued

8. **Gravitational Force** What is the gravitational force between two 15-kg packages that are 35 cm apart? What fraction is this of the weight of one package?

$$\begin{aligned}F_g &= G \frac{m_E m}{r^2} \\&= \frac{(6.67 \times 10^{-11} \text{ N} \cdot \text{m}^2 / \text{kg}^2)(15 \text{ kg})^2}{(0.35 \text{ m})^2} \\&= 1.2 \times 10^{-7} \text{ N}\end{aligned}$$

Because the weight is $mg = 147 \text{ N}$, the gravitational force is 8.2×10^{-10} or 0.82 parts per billion of the weight.

9. **Universal Gravitational Constant** Cavendish did his experiment using lead spheres. Suppose he had replaced the lead spheres with copper spheres of equal mass. Would his value of G be the same or different? Explain.

It would be the same, because the same value of G has been used successfully to describe the attraction of bodies having diverse chemical compositions: the Sun (a star), the planets, and satellites.

10. **Laws or Theories?** Kepler's three statements and Newton's equation for gravitational attraction are called "laws." Were they ever theories? Will they ever become theories?

No. A scientific law is a statement of what has been observed to happen many times. A theory explains scientific results. None of these statements offers explanations for why the motion of planets are as they are or for why gravitational attraction acts as it does.

11. **Critical Thinking** Picking up a rock requires less effort on the Moon than on Earth.

- a. How will the weaker gravitational force on the Moon's surface affect the path of the rock if it is thrown horizontally?

Horizontal throwing requires the same effort because the inertial character, $F = ma$, of the rock is involved. The mass of the rock depends only on the amount of matter in the rock, not on its location in the universe. The path would still be a parabola, but it could be much wider because the rock would go farther before it hits the ground, given the smaller acceleration rate and longer time of flight.

- b. If the thrower accidentally drops the rock on her toe, will it hurt more or less than it would on Earth? Explain.

Assume the rocks would be dropped from the same height on Earth and on the Moon. It will hurt less because the smaller value of g on the Moon means that the rock strikes the toe with a smaller velocity than on Earth.

Practice Problems

7.2 Using the Law of Universal of Gravitation pages 179–185

page 181

For the following problems, assume a circular orbit for all calculations.

12. Suppose that the satellite in Example Problem 2 is moved to an orbit that is 24 km larger in radius than its previous orbit. What would its speed be? Is this faster or slower than its previous speed?

$$\begin{aligned} r &= (h + 2.40 \times 10^4 \text{ m}) + r_E \\ &= (2.25 \times 10^5 \text{ m} + 2.40 \times 10^4 \text{ m}) + 6.38 \times 10^6 \text{ m} = 6.63 \times 10^6 \text{ m} \end{aligned}$$

$$\begin{aligned} v &= \sqrt{\frac{Gm_E}{r}} \\ &= \sqrt{\frac{(6.67 \times 10^{-11} \text{ N} \cdot \text{m}^2/\text{kg}^2)(5.97 \times 10^{24} \text{ kg})}{6.63 \times 10^6 \text{ m}}} \\ &= 7.75 \times 10^3 \text{ m/s, slower} \end{aligned}$$

13. Use Newton's thought experiment on the motion of satellites to solve the following.
- a. Calculate the speed that a satellite shot from a cannon must have to orbit Earth 150 km above its surface.

$$\begin{aligned} v &= \sqrt{\frac{Gm_E}{r}} = \sqrt{\frac{(6.67 \times 10^{-11} \text{ N} \cdot \text{m}^2/\text{kg}^2)(5.97 \times 10^{24} \text{ kg})}{(6.38 \times 10^6 \text{ m} + 1.5 \times 10^5 \text{ m})}} \\ &= 7.8 \times 10^3 \text{ m/s} \end{aligned}$$

- b. How long, in seconds and minutes, would it take for the satellite to complete one orbit and return to the cannon?

$$\begin{aligned} T &= 2\pi \sqrt{\frac{r^3}{Gm_E}} = 2\pi \sqrt{\frac{(6.38 \times 10^6 \text{ m} + 1.5 \times 10^5 \text{ m})^3}{(6.67 \times 10^{-11} \text{ N} \cdot \text{m}^2/\text{kg}^2)(5.97 \times 10^{24} \text{ kg})}} \\ &= 5.3 \times 10^3 \text{ s} \approx 88 \text{ min} \end{aligned}$$

14. Use the data for Mercury in Table 7-1 on page 173 to find the following.
- a. the speed of a satellite that is in orbit 260 km above Mercury's surface

$$\begin{aligned} v &= \sqrt{\frac{Gm_M}{r}} \\ r &= r_M + 260 \text{ km} \\ &= 2.44 \times 10^6 \text{ m} + 0.26 \times 10^6 \text{ m} \\ &= 2.70 \times 10^6 \text{ m} \\ v &= \sqrt{\frac{(6.67 \times 10^{-11} \text{ N} \cdot \text{m}^2/\text{kg}^2)(3.30 \times 10^{23} \text{ kg})}{2.70 \times 10^6 \text{ m}}} \\ &= 2.86 \times 10^3 \text{ m/s} \end{aligned}$$

- b. the period of the satellite

$$\begin{aligned} T &= 2\pi \sqrt{\frac{r^3}{Gm_M}} = 2\pi \sqrt{\frac{(2.70 \times 10^6 \text{ m})^3}{(6.67 \times 10^{-11} \text{ N} \cdot \text{m}^2/\text{kg}^2)(3.30 \times 10^{23} \text{ kg})}} \\ &= 5.94 \times 10^3 \text{ s} = 1.65 \text{ h} \end{aligned}$$

Section Review

7.2 Using the Law of Universal of Gravitation pages 179–185

page 185

15. Gravitational Fields The Moon is 3.9×10^5 km from Earth's center and 1.5×10^8 km from the Sun's center. The masses of Earth and the Sun are 6.0×10^{24} kg and 2.0×10^{30} kg, respectively.

- a. Find the ratio of the gravitational fields due to Earth and the Sun at the center of the Moon.

$$\text{Gravitational field due to the Sun: } g_S = G \frac{m_S}{r_S^2}$$

$$\text{Gravitational field due to Earth: } g_E = G \frac{m_E}{r_E^2}$$

$$\frac{g_S}{g_E} = \left(\frac{m_S}{m_E} \right) \left(\frac{r_E^2}{r_S^2} \right)$$

$$= \frac{(2.0 \times 10^{30} \text{ kg})(3.9 \times 10^5 \text{ km})^2}{(6.0 \times 10^{24} \text{ kg})(1.5 \times 10^8 \text{ km})^2}$$

$$= 2.3$$

- b. When the Moon is in its third quarter phase, as shown in **Figure 7-17**, its direction from Earth is at right angles to the Sun's direction. What is the net gravitational field due to the Sun and Earth at the center of the Moon?

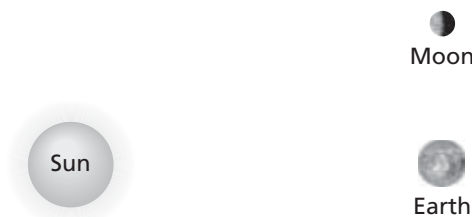

■ Figure 7-17

Because the directions are at right angles, the net field is the square root of the sum of the squares of the two fields.

$$\begin{aligned} g_S &= \frac{Gm_S}{r^2} \\ &= \frac{(6.67 \times 10^{-11} \text{ N}\cdot\text{m}^2/\text{kg}^2)(2.0 \times 10^{30} \text{ kg})}{(1.5 \times 10^{11} \text{ m})^2} \\ &= 5.9 \times 10^{-3} \text{ N/kg} \end{aligned}$$

$$\text{Similarly, } g_E = 2.6 \times 10^{-3} \text{ N/kg}$$

$$\begin{aligned} g_{\text{net}} &= \sqrt{(5.9 \times 10^{-3} \text{ N/kg})^2 + (2.6 \times 10^{-3} \text{ N/kg})^2} \\ &= 6.4 \times 10^{-3} \text{ N/kg} \end{aligned}$$

16. Gravitational Field The mass of the Moon is 7.3×10^{22} kg and its radius is 1785 km. What is the strength of the gravitational field on the surface of the Moon?

$$\begin{aligned} g &= \frac{GM}{r^2} = \frac{(6.67 \times 10^{-11} \text{ N}\cdot\text{m}^2/\text{kg}^2)(7.3 \times 10^{22} \text{ kg})}{(1.785 \times 10^3 \text{ m})^2} \\ &= 1.5 \text{ N/kg, about one-sixth that on Earth} \end{aligned}$$

Chapter 7 continued

- 17. A Satellite's Mass** When the first artificial satellite was launched into orbit by the former Soviet Union in 1957, U.S. president Dwight D. Eisenhower asked his scientific advisors to calculate the mass of the satellite. Would they have been able to make this calculation? Explain.

No. Because the speed and period of the orbit don't depend at all on the mass of the satellite, the scientific advisors would not have been able to calculate the mass of the satellite.

- 18. Orbital Period and Speed** Two satellites are in circular orbits about Earth. One is 150 km above the surface, the other 160 km.

- a. Which satellite has the larger orbital period?

When the orbital radius is large, the period also will be large. Thus, the one at 160 km will have the larger period.

- b. Which one has the greater speed?

The one at 150 km, because the smaller the orbital radius, the greater the speed.

- 19. Theories and Laws** Why is Einstein's description of gravity called a "theory," while Newton's is a "law?"

Newton's law describes how to calculate the force between two massive objects. Einstein's theory explains how an object, such as Earth, attracts the Moon.

- 20. Weightlessness** Chairs in an orbiting spacecraft are weightless. If you were on board such a spacecraft and you were barefoot, would you stub your toe if you kicked a chair? Explain.

Yes. The chairs are weightless but not massless. They still have inertia and can exert contact forces on your toe.

- 21. Critical Thinking** It is easier to launch a satellite from Earth into an orbit that circles eastward than it is to launch one that circles westward. Explain.

Earth rotates toward the east, and its velocity adds to the velocity given to the satellite by the rocket, thereby reducing the velocity that the rocket must supply.

Chapter Assessment

Concept Mapping

page 190

- 22.** Create a concept map using these terms: *planets, stars, Newton's law of universal gravitation, Kepler's first law, Kepler's second law, Kepler's third law, Einstein's general theory of relativity.*

Chapter 7 continued

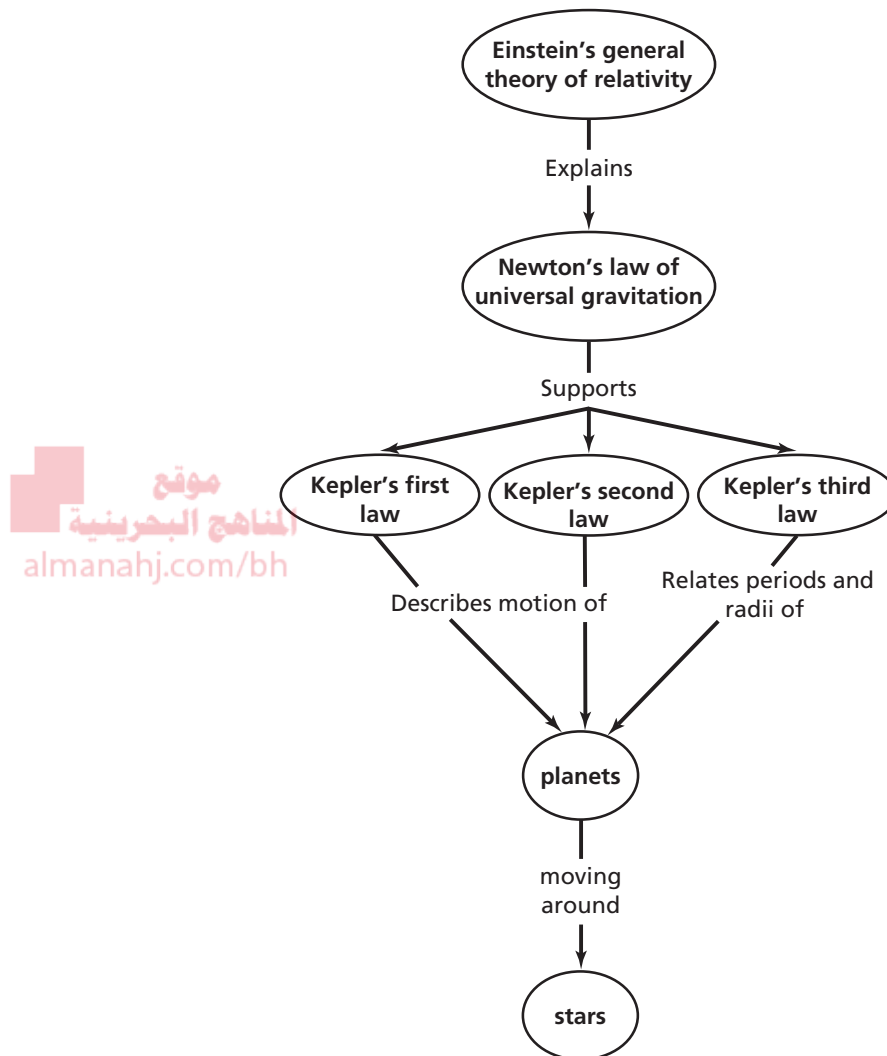

Kepler's first and second laws describe the motion of a single planet. Kepler's third law describes the periods versus the orbital radii of all planets around a star. Newton's law of universal gravitation supports Kepler's laws. Einstein's theory explains Newton's and Kepler's laws.

Mastering Concepts

page 190

- 23.** In 1609, Galileo looked through his telescope at Jupiter and saw four moons. The name of one of the moons that he saw is Io. Restate Kepler's first law for Io and Jupiter. (7.1)

The path of Io is an ellipse, with Jupiter at one focus.

- 24.** Earth moves more slowly in its orbit during summer in the northern hemisphere than it does during winter. Is it closer to the Sun in summer or in winter? (7.1)

Because Earth moves more slowly in its orbit during summer, by Kepler's second law, it must be farther from the Sun. Therefore, Earth is closer to the Sun in the winter months.

Chapter 7 continued

25. Is the area swept out per unit of time by Earth moving around the Sun equal to the area swept out per unit of time by Mars moving around the Sun? (7.1)

No. The equality of the area swept out per unit of time applies to each planet individually.

26. Why did Newton think that a force must act on the Moon? (7.1)

Newton knew that the Moon followed a curved path; therefore, it was accelerated. He also knew that a force is required for acceleration.

27. How did Cavendish demonstrate that a gravitational force of attraction exists between two small objects? (7.1)

He carefully measured the masses, the distance between the masses, and the force of attraction. He then calculated G using Newton's law of universal gravitation.

28. What happens to the gravitational force between two masses when the distance between the masses is doubled? (7.1)

According to Newton, $F \propto 1/r^2$. If the distance is doubled, the force is cut to one-fourth.

29. According to Newton's version of Kepler's third law, how would the ratio T^2/r^3 change if the mass of the Sun were doubled? (7.1)

Because $T^2/r^3 = 4\pi^2/Gm_S$, if the mass of the Sun, m_S , is doubled, the ratio will be halved.

30. How do you answer the question, "What keeps a satellite up?" (7.2)

Its speed; it is falling all the time.

31. A satellite is orbiting Earth. On which of the following does its speed depend? (7.2)

- a. mass of the satellite
- b. distance from Earth
- c. mass of Earth

Speed depends only on b, the distance from the Earth, and c, the mass of Earth.

32. What provides the force that causes the centripetal acceleration of a satellite in orbit? (7.2)

gravitational attraction to the central body

33. During space flight, astronauts often refer to forces as multiples of the force of gravity on Earth's surface. What does a force of $5g$ mean to an astronaut? (7.2)

A force of $5g$ means that an astronaut's weight is five times heavier than it is on Earth. The force exerted on the astronaut is five times the force of Earth's gravitational force.

34. Newton assumed that a gravitational force acts directly between Earth and the Moon. How does Einstein's view of the attractive force between the two bodies differ from Newton's view? (7.2)

Einstein's view is that gravity is an effect of the curvature of space as a result of the presence of mass, whereas Newton's view of gravity is that it is a force acting directly between objects. Thus, according to Einstein, the attraction between Earth and the Moon is the effect of curvature of space caused by their combined masses.

35. Show that the dimensions of g in the equation $g = F/m$ are in m/s^2 . (7.2)

The units of $\frac{F}{m}$ are $\frac{\text{N}}{\text{kg}} = \frac{\text{kg}\cdot\text{m/s}^2}{\text{kg}} = \text{m/s}^2$

36. If Earth were twice as massive but remained the same size, what would happen to the value of g ? (7.2)

The value of g would double.

Applying Concepts

pages 190–191

37. **Golf Ball** The force of gravity acting on an object near Earth's surface is proportional to the mass of the object. **Figure 7-18** shows a tennis ball and golf ball in free fall. Why does a tennis ball not fall faster than a golf ball?

Chapter 7 continued



■ Figure 7-18

$$F = G \frac{m_1 m_2}{r^2}$$

$m_1 =$ Earth's mass

$$a = \frac{F}{m_2}$$

$m_2 =$ object's mass

$$\text{Thus, } a = \frac{Gm_1}{r^2}$$

The acceleration is independent of the object's mass. This is because more massive objects require more force to accelerate at the same rate.

38. What information do you need to find the mass of Jupiter using Newton's version of Kepler's third law?

You must know the period and orbital radius of at least one of its satellites.

39. The mass of Pluto was not known until a satellite of the planet was discovered. Why?

Orbital motion of a planet does not depend on its mass and cannot be used to find the mass. A satellite orbiting the planet is necessary to find the planet's mass.

40. Decide whether each of the orbits shown in Figure 7-19 is a possible orbit for a planet.

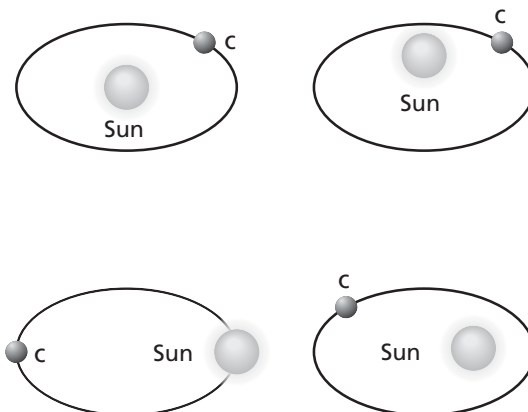

■ Figure 7-19

Only d (lower right) is possible. a (top left) and b (top right) do not have the Sun at a focus, and in c (lower left), the planet is not in orbit around the Sun.

41. The Moon and Earth are attracted to each other by gravitational force. Does the more-massive Earth attract the Moon with a greater force than the Moon attracts Earth? Explain.

No. The forces constitute an action-reaction pair, so under Newton's third law, they are equal and opposite.

42. What would happen to the value of G if Earth were twice as massive, but remained the same size?

Nothing. G is a universal constant, and it is independent of Earth's mass. However, the force of attraction would double.

43. Figure 7-20 shows a satellite orbiting Earth.

Examine the equation $v = \sqrt{\frac{Gm_E}{r}}$, relating the speed of an orbiting satellite and its distance from the center of Earth. Does a satellite with a large or small orbital radius have the greater velocity?

Chapter 7 continued

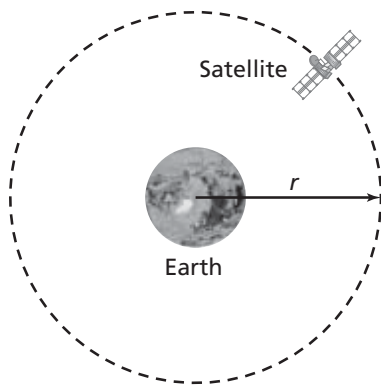

■ Figure 7-20 (Not to scale)

A satellite with a small radius has the greater velocity.

44. **Space Shuttle** If a space shuttle goes into a higher orbit, what happens to the shuttle's period?

Because $T = 2\pi\sqrt{\frac{r^3}{Gm}}$, if the orbital radius increases, so will the period.

45. Mars has about one-ninth the mass of Earth. **Figure 7-21** shows satellite M, which orbits Mars with the same orbital radius as satellite E, which orbits Earth. Which satellite has a smaller period?

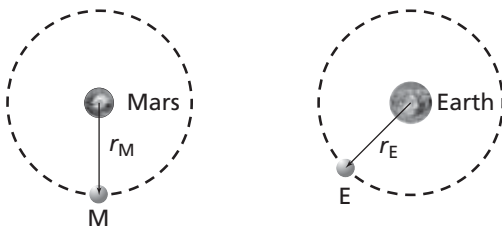

■ Figure 7-21 (Not to scale)

Because $T = 2\pi\sqrt{\frac{r^3}{Gm}}$, as the mass of the planet increases, the period of the satellite decreases. Because Earth has a larger mass than Mars, Earth's satellite will have a smaller period.

46. Jupiter has about 300 times the mass of Earth and about ten times Earth's radius. Estimate the size of g on the surface of Jupiter.

$g \propto \frac{m_E}{r_E^2}$. If Jupiter has 300 times the mass and ten times the radius of Earth,

$g \propto \frac{300}{10^2} = 3$. Thus, g on Jupiter is three times that on Earth.

47. A satellite is one Earth radius above the surface of Earth. How does the acceleration due to gravity at that location compare to acceleration at the surface of Earth?

$$d = r_E + r_E = 2r_E$$

$$\text{so, } a = g\left(\frac{r_E}{2r_E}\right)^2 = \frac{1}{4}g$$

48. If a mass in Earth's gravitational field is doubled, what will happen to the force exerted by the field upon the mass?

It also will double.

49. **Weight** Suppose that yesterday your body had a mass of 50.0 kg. This morning you stepped on a scale and found that you had gained weight.

- a. What happened, if anything, to your mass?

Your mass increased.

- b. What happened, if anything, to the ratio of your weight to your mass?

The ratio remained constant because it is equal to the gravitational field at the location, a constant = g .

50. As an astronaut in an orbiting space shuttle, how would you go about "dropping" an object down to Earth?

To "drop" an object down to Earth, you would have to launch it backward at the same speed at which you are traveling in orbit. With respect to Earth, the object's speed perpendicular to Earth's gravity would be zero, and it could then "drop" down to Earth. However, the object is likely to burn up as a result of friction with Earth's atmosphere on the way down.

51. **Weather Satellites** The weather pictures that you see every day on TV come from a spacecraft in a stationary position relative to

Chapter 7 continued

the surface of Earth, 35,700 km above Earth's equator. Explain how it can stay in exactly the same position day after day. What would happen if it were closer? Farther out? *Hint: Draw a pictorial model.*

The satellite is positioned as close to the equator as possible so it doesn't appear to have much north-south movement. Because it is placed at that distance, the satellite has a period of 24.0 h. If it were positioned any closer, its period would be less than 24.0 h and it would appear to move toward the east. If it were positioned any farther, its period would be longer than 24.0 h.

Mastering Problems

7.1 Planetary Motion and Gravitation

pages 191–192

Level 1

52. Jupiter is 5.2 times farther from the Sun than Earth is. Find Jupiter's orbital period in Earth years.

$$\begin{aligned} \left(\frac{T_J}{T_E}\right)^2 &= \left(\frac{r_J}{r_E}\right)^3 \\ T_J &= \sqrt{\left(\frac{r_J}{r_E}\right)^3 T_E^2} \\ &= \sqrt{\left(\frac{5.2}{1.0}\right)^3 (1.0 \text{ y})^2} \\ &= \sqrt{141 \text{ y}^2} \\ &= 12 \text{ y} \end{aligned}$$

53. **Figure 7-22** shows a Cavendish apparatus like the one used to find G . It has a large lead sphere that is 5.9 kg in mass and a small one with a mass of 0.047 kg. Their centers are separated by 0.055 m. Find the force of attraction between them.

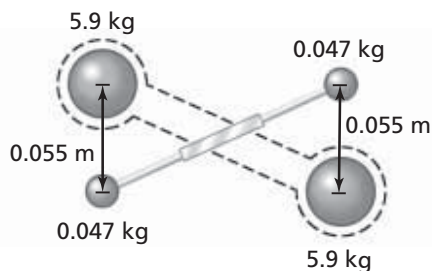

■ **Figure 7-22**

$$\begin{aligned} F &= G \frac{m_S m_J}{r^2} \\ &= (6.67 \times 10^{-11} \text{ N} \cdot \text{m}^2/\text{kg}^2) \\ &\quad \frac{(5.9 \text{ kg})(4.7 \times 10^{-2} \text{ kg})}{(5.5 \times 10^{-2} \text{ m})^2} \\ &= 6.1 \times 10^{-9} \text{ N} \end{aligned}$$

54. Use Table 7-1 on p. 173 to compute the gravitational force that the Sun exerts on Jupiter.

$$\begin{aligned} F &= G \frac{m_1 m_2}{r^2} \\ &= (6.67 \times 10^{-11} \text{ N} \cdot \text{m}^2/\text{kg}^2) \\ &\quad \frac{(1.99 \times 10^{30} \text{ kg})(1.90 \times 10^{27} \text{ kg})}{(7.78 \times 10^{11} \text{ m})^2} \\ &= 4.17 \times 10^{23} \text{ N} \end{aligned}$$

55. Tom has a mass of 70.0 kg and Sally has a mass of 50.0 kg. Tom and Sally are standing 20.0 m apart on the dance floor. Sally looks up and sees Tom. She feels an attraction. If the attraction is gravitational, find its size. Assume that both Tom and Sally can be replaced by spherical masses.

$$\begin{aligned} F &= G \frac{m_T m_S}{r^2} \\ &= (6.67 \times 10^{-11} \text{ N} \cdot \text{m}^2/\text{kg}^2) \\ &\quad \frac{(70.0 \text{ kg})(50.0 \text{ kg})}{(20.0 \text{ m})^2} \\ &= 5.84 \times 10^{-10} \text{ N} \end{aligned}$$

56. Two balls have their centers 2.0 m apart, as shown in **Figure 7-23**. One ball has a mass of 8.0 kg. The other has a mass of 6.0 kg. What is the gravitational force between them?

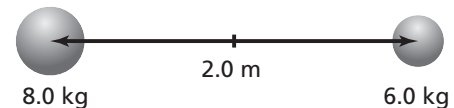

■ **Figure 7-23**

$$\begin{aligned} F &= G \frac{m_1 m_2}{r^2} \\ &= (6.67 \times 10^{-11} \text{ N} \cdot \text{m}^2/\text{kg}^2) \\ &\quad \frac{(8.0 \text{ kg})(6.0 \text{ kg})}{(2.0 \text{ m})^2} \\ &= 8.0 \times 10^{-10} \text{ N} \end{aligned}$$

Chapter 7 continued

57. Two bowling balls each have a mass of 6.8 kg. They are located next to each other with their centers 21.8 cm apart. What gravitational force do they exert on each other?

$$\begin{aligned}
 F &= G \frac{m_1 m_2}{r^2} \\
 &= \frac{(6.67 \times 10^{-11} \text{ N}\cdot\text{m}^2/\text{kg}^2)(6.8 \text{ kg})(6.8 \text{ kg})}{(0.218 \text{ m})^2} \\
 &= 6.5 \times 10^{-8} \text{ N}
 \end{aligned}$$

58. Assume that you have a mass of 50.0 kg. Earth has a mass of 5.97×10^{24} kg and a radius of 6.38×10^6 m.

- a. What is the force of gravitational attraction between you and Earth?

Sample answer:

$$\begin{aligned}
 F &= G \frac{m_S m_E}{r^2} \\
 &= \frac{(6.67 \times 10^{-11} \text{ N}\cdot\text{m}^2/\text{kg}^2)(50.0 \text{ kg})(5.97 \times 10^{24} \text{ kg})}{(6.38 \times 10^6 \text{ m})^2} \\
 &= 489 \text{ N}
 \end{aligned}$$

- b. What is your weight?

Sample answer:

$$\begin{aligned}
 F_g &= mg = (50.0 \text{ kg})(9.80 \text{ m/s}^2) \\
 &= 4.90 \times 10^2 \text{ N}
 \end{aligned}$$

59. The gravitational force between two electrons that are 1.00 m apart is 5.54×10^{-71} N. Find the mass of an electron.

$$F = G \frac{m_1 m_2}{r^2}, \text{ where } m_1 = m_2 = m_e$$

$$\begin{aligned}
 \text{So } m_e &= \sqrt{\frac{Fr^2}{G}} \\
 &= \sqrt{\frac{(5.54 \times 10^{-71} \text{ N})(1.00 \text{ m})^2}{6.67 \times 10^{-11} \text{ N}\cdot\text{m}^2/\text{kg}^2}} \\
 &= 9.11 \times 10^{-31} \text{ kg}
 \end{aligned}$$

60. A 1.0-kg mass weighs 9.8 N on Earth's surface, and the radius of Earth is roughly 6.4×10^6 m.

- a. Calculate the mass of Earth.

$$F = G \frac{m_1 m_2}{r^2}$$

$$\begin{aligned}
 m_E &= \frac{Fr^2}{Gm} \\
 &= \frac{(9.8 \text{ N})(6.4 \times 10^6 \text{ m})^2}{(6.67 \times 10^{-11} \text{ N}\cdot\text{m}^2/\text{kg}^2)(1.0 \text{ kg})} \\
 &= 6.0 \times 10^{24} \text{ kg}
 \end{aligned}$$

- b. Calculate the average density of Earth.

$$\begin{aligned}
 V &= \frac{4}{3} \pi r^3 = \frac{(4\pi)(6.4 \times 10^6 \text{ m})^3}{3} \\
 &= 1.1 \times 10^{21} \text{ m}^3 \\
 D &= \frac{m}{V} = \frac{6.0 \times 10^{24} \text{ kg}}{1.1 \times 10^{21} \text{ m}^3} \\
 &= 5.5 \times 10^3 \text{ kg/m}^3
 \end{aligned}$$

61. **Uranus** Uranus requires 84 years to circle the Sun. Find Uranus's orbital radius as a multiple of Earth's orbital radius.

$$\begin{aligned}
 \left(\frac{T_U}{T_E}\right)^2 &= \left(\frac{r_U}{r_E}\right)^3 \\
 \frac{r_U}{r_E} &= \sqrt[3]{\left(\frac{T_U}{T_E}\right)^2} \\
 &= \sqrt[3]{\left(\frac{84 \text{ y}}{1.0 \text{ y}}\right)^2} \\
 &= 19
 \end{aligned}$$

$$\text{So } r_U = 19r_E$$

62. **Venus** Venus has a period of revolution of 225 Earth days. Find the distance between the Sun and Venus as a multiple of Earth's orbital radius.

$$\begin{aligned}
 \left(\frac{T_V}{T_E}\right)^2 &= \left(\frac{r_V}{r_E}\right)^3 \\
 \frac{r_V}{r_E} &= \sqrt[3]{\left(\frac{T_V}{T_E}\right)^2} \\
 &= \sqrt[3]{\left(\frac{225 \text{ days}}{365 \text{ days}}\right)^2} \\
 &= 0.724
 \end{aligned}$$

$$\text{So } r_V = 0.724r_E$$

Level 2

63. If a small planet, D, were located 8.0 times as far from the Sun as Earth is, how many years would it take the planet to orbit the Sun?

$$\left(\frac{T_D}{T_E}\right)^2 = \left(\frac{r_D}{r_E}\right)^3$$

Chapter 7 continued

$$T_D = \sqrt{\left(\frac{r_D}{r_E}\right)^3 T_E^2} = \sqrt{\left(\frac{8.0}{1.0}\right)^3 (1.0 \text{ y})^2} = 23 \text{ years}$$

64. Two spheres are placed so that their centers are 2.6 m apart. The force between the two spheres is 2.75×10^{-12} N. What is the mass of each sphere if one sphere is twice the mass of the other sphere?

$$F = G \frac{m_1 m_2}{r^2}, \text{ where } m_2 = 2m_1$$

$$F = G \frac{(m_1)(2m_1)}{r^2}$$

$$m_1 = \sqrt{\frac{Fr^2}{2G}}$$

$$= \sqrt{\frac{(2.75 \times 10^{-12} \text{ N})(2.6 \text{ m})^2}{(2)(6.67 \times 10^{-11} \text{ N} \cdot \text{m}^2/\text{kg}^2)}}$$

$$= 0.3733 \text{ kg or } 0.37 \text{ kg to two significant digits}$$

$$m_2 = 2m_1 = (2)(0.3733 \text{ kg}) = 0.7466 \text{ kg or } 0.75 \text{ to two significant digits}$$

65. The Moon is 3.9×10^5 km from Earth's center and 1.5×10^8 km from the Sun's center. If the masses of the Moon, Earth, and the Sun are 7.3×10^{22} kg, 6.0×10^{24} kg, and 2.0×10^{30} kg, respectively, find the ratio of the gravitational forces exerted by Earth and the Sun on the Moon.

$$F = G \frac{m_1 m_2}{r^2}$$

$$\text{Earth on Moon: } F_E = (6.67 \times 10^{-11} \text{ N} \cdot \text{m}^2/\text{kg}^2) \frac{(6.0 \times 10^{24} \text{ kg})(7.3 \times 10^{22} \text{ kg})}{(3.9 \times 10^8 \text{ m})^2}$$

$$= 1.9 \times 10^{20} \text{ N}$$

$$\text{Sun on Moon: } F_S = (6.67 \times 10^{-11} \text{ N} \cdot \text{m}^2/\text{kg}^2) \frac{(2.0 \times 10^{30} \text{ kg})(7.3 \times 10^{22} \text{ kg})}{(1.5 \times 10^{11} \text{ m})^2}$$

$$= 4.3 \times 10^{20} \text{ N}$$

$$\text{Ratio is } \frac{F_E}{F_S} = \frac{1.9 \times 10^{20} \text{ N}}{4.3 \times 10^{20} \text{ N}} = \frac{1.0}{2.3}$$

The Sun pulls more than twice as hard on the Moon as does Earth.

66. **Toy Boat** A force of 40.0 N is required to pull a 10.0-kg wooden toy boat at a constant velocity across a smooth glass surface on Earth. What force would be required to pull the same wooden toy boat across the same glass surface on the planet Jupiter?

$$\mu = \frac{F_f}{F_N} = \frac{F_f}{m_b g}, \text{ where } m_b \text{ is the mass of the toy boat.}$$

On Jupiter, the normal force is equal to the gravitational attraction between the toy boat and Jupiter, or

$$F_N = G \frac{m_b m_J}{r_J^2}$$

$$\text{Now } \mu = \frac{F_f}{F_N}, \text{ so } F_{fJ} = \mu F_N = \mu G \frac{m_b m_J}{r_J^2}$$

Chapter 7 continued

$$\begin{aligned} \text{But } \mu &= \frac{F_f}{m_b g}, \text{ so } F_{fJ} \\ &= F_f G \frac{m_b m_J}{m_b g r_J^2} = F_f G \frac{m_J}{g r_J^2} = \frac{(40.0 \text{ N})(6.67 \times 10^{-11} \text{ N}\cdot\text{m}^2/\text{kg}^2)(1.90 \times 10^{27} \text{ kg})}{(9.80 \text{ m/s}^2)(7.15 \times 10^7 \text{ m})^2} \\ &= 101 \text{ N} \end{aligned}$$

67. Mimas, one of Saturn's moons, has an orbital radius of $1.87 \times 10^8 \text{ m}$ and an orbital period of about 23.0 h. Use Newton's version of Kepler's third law to find Saturn's mass.

$$\begin{aligned} T^2 &= \left(\frac{4\pi^2}{Gm}\right)r^3 \\ m &= \frac{4\pi^2 r^3}{GT^2} \\ &= \frac{4\pi^2(1.87 \times 10^8 \text{ m})^3}{(6.67 \times 10^{-11} \text{ N}\cdot\text{m}^2/\text{kg}^2)(8.28 \times 10^4 \text{ s})^2} \\ &= 5.6 \times 10^{26} \text{ kg} \end{aligned}$$

Level 3

68. The Moon is $3.9 \times 10^8 \text{ m}$ away from Earth and has a period of 27.33 days. Use Newton's version of Kepler's third law to find the mass of Earth. Compare this mass to the mass found in problem 60.

$$\begin{aligned} T^2 &= \left(\frac{4\pi^2}{Gm}\right)r^3 \\ m &= \left(\frac{4\pi^2}{G}\right)\frac{r^3}{T^2} \\ &= \left(\frac{4\pi^2}{(6.67 \times 10^{-11} \text{ N}\cdot\text{m}^2/\text{kg}^2)}\right)\frac{(3.9 \times 10^8 \text{ m})^3}{(2.361 \times 10^6 \text{ s})^2} \\ &= 6.3 \times 10^{24} \text{ kg} \end{aligned}$$

The mass is considerably close to that found in problem 60.

69. **Halley's Comet** Every 74 years, comet Halley is visible from Earth. Find the average distance of the comet from the Sun in astronomical units (AU).

For Earth, $r = 1.0 \text{ AU}$ and $T = 1.0 \text{ y}$

$$\begin{aligned} \left(\frac{r_a}{r_b}\right)^3 &= \left(\frac{T_a}{T_b}\right)^2 \\ r_a &= \sqrt[3]{r_b^3 \left(\frac{T_a}{T_b}\right)^2} = \sqrt[3]{(1.0 \text{ AU})^3 \left(\frac{74 \text{ y}}{1.0 \text{ y}}\right)^2} \\ &= 18 \text{ AU} \end{aligned}$$

70. Area is measured in m^2 , so the rate at which area is swept out by a planet or satellite is measured in m^2/s .

- a. How quickly is an area swept out by Earth in its orbit about the Sun?

$$\begin{aligned} r &= 1.50 \times 10^{11} \text{ m and} \\ T &= 3.156 \times 10^7 \text{ s, in } 365.25 \text{ days} = 1.00 \text{ y} \\ \frac{\pi r^2}{T} &= \frac{\pi(1.50 \times 10^{11} \text{ m})^2}{3.156 \times 10^7 \text{ s}} = 2.24 \times 10^{15} \text{ m}^2/\text{s} \end{aligned}$$

Chapter 7 continued

- b. How quickly is an area swept out by the Moon in its orbit about Earth? Use 3.9×10^8 m as the average distance between Earth and the Moon, and 27.33 days as the period of the Moon.

$$\frac{\pi(3.9 \times 10^8 \text{ m})^2}{2.36 \times 10^6 \text{ s}} = 2.0 \times 10^{11} \text{ m}^2/\text{s}$$

7.2 Using the Law of Universal Gravitation

pages 192–193

Level 1

- 71. Satellite** A geosynchronous satellite is one that appears to remain over one spot on Earth, as shown in **Figure 7-24**. Assume that a geosynchronous satellite has an orbital radius of 4.23×10^7 m.

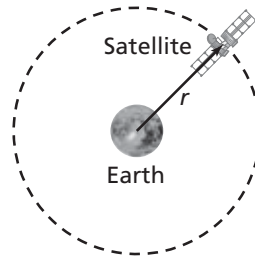

■ **Figure 7-24** (Not to scale)

- a. Calculate its speed in orbit.

$$\begin{aligned} v &= \sqrt{\frac{Gm_E}{r}} \\ &= \sqrt{\frac{(6.67 \times 10^{-11} \text{ N}\cdot\text{m}^2/\text{kg}^2)(5.97 \times 10^{24} \text{ kg})}{4.23 \times 10^7 \text{ m}}} \\ &= 3.07 \times 10^3 \text{ m/s or } 3.07 \text{ km/s} \end{aligned}$$

- b. Calculate its period.

$$\begin{aligned} T &= 2\pi \sqrt{\frac{r^3}{Gm_E}} \\ &= 2\pi \sqrt{\frac{(4.23 \times 10^7 \text{ m})^3}{(6.67 \times 10^{-11} \text{ N}\cdot\text{m}^2/\text{kg}^2)(5.97 \times 10^{24} \text{ kg})}} \\ &= 2\pi \sqrt{1.90 \times 10^8 \text{ s}^2} \\ &= 8.66 \times 10^4 \text{ s or } 24.1 \text{ h} \end{aligned}$$

- 72. Asteroid** The asteroid Ceres has a mass of 7×10^{20} kg and a radius of 500 km.

- a. What is g on the surface of Ceres?

$$\begin{aligned} g &= \frac{Gm}{r^2} \\ &= \frac{(6.67 \times 10^{-11} \text{ N}\cdot\text{m}^2/\text{kg}^2)(7 \times 10^{20} \text{ kg})}{(500 \times 10^3 \text{ m})^2} \\ &= 0.2 \text{ m/s}^2 \end{aligned}$$

- b. How much would a 90-kg astronaut weigh on Ceres?

$$F_g = mg = (90 \text{ kg})(0.2 \text{ m/s}^2) = 20 \text{ N}$$

Chapter 7 continued

- 73. Book** A 1.25-kg book in space has a weight of 8.35 N. What is the value of the gravitational field at that location?

$$g = \frac{F}{m} = \frac{8.35 \text{ N}}{1.25 \text{ kg}} = 6.68 \text{ N/kg}$$

- 74.** The Moon's mass is 7.34×10^{22} kg, and it is 3.8×10^8 m away from Earth. Earth's mass is 5.97×10^{24} kg.

- a.** Calculate the gravitational force of attraction between Earth and the Moon.

$$\begin{aligned} F &= G \frac{m_E m_M}{r^2} \\ &= (6.67 \times 10^{-11} \text{ N}\cdot\text{m}^2/\text{kg}^2) \frac{(5.98 \times 10^{24} \text{ kg})(7.34 \times 10^{22} \text{ kg})}{(3.8 \times 10^8 \text{ m})^2} \\ &= 2.0 \times 10^{20} \text{ N} \end{aligned}$$

- b.** Find Earth's gravitational field at the Moon.

$$g = \frac{F}{m} = \frac{2.03 \times 10^{20} \text{ N}}{7.34 \times 10^{22} \text{ kg}} = 0.0028 \text{ N/kg}$$

Note that 2.03×10^{20} N instead of 2.0×10^{20} N is used to prevent roundoff error.

- 75.** Two 1.00-kg masses have their centers 1.00 m apart. What is the force of attraction between them?

$$\begin{aligned} F_g &= G \frac{m_1 m_2}{r^2} \\ &= \frac{(6.67 \times 10^{-11} \text{ N}\cdot\text{m}^2/\text{kg}^2)(1.00 \text{ kg})(1.00 \text{ kg})}{(1.00 \text{ m})^2} \\ &= 6.67 \times 10^{-11} \text{ N} \end{aligned}$$

Level 2

- 76.** The radius of Earth is about 6.38×10^3 km. A 7.20×10^3 -N spacecraft travels away from Earth. What is the weight of the spacecraft at the following distances from Earth's surface?

- a.** 6.38×10^3 km

$$d = r_E + r_E = 2r_E$$

$$\text{Therefore, } F_g = \frac{1}{4} \text{ original weight} = \left(\frac{1}{4}\right)(7.20 \times 10^3 \text{ N}) = 1.80 \times 10^3 \text{ N}$$

- b.** 1.28×10^4 km

$$d = r_E + 2r_E = 3r_E$$

$$F_g = \left(\frac{1}{9}\right)(7.20 \times 10^3 \text{ N}) = 8.00 \times 10^2 \text{ N}$$

- 77. Rocket** How high does a rocket have to go above Earth's surface before its weight is half of what it is on Earth?

$$F_g \propto \frac{1}{r^2}$$

$$\text{So } r \propto \sqrt{\frac{1}{F_g}}$$

Chapter 7 continued

If the weight is $\frac{1}{2}$, the distance is $\sqrt{2}(r_E)$ or

$$r = \sqrt{2}(6.38 \times 10^6 \text{ m}) = 9.02 \times 10^6 \text{ m}$$

$$9.02 \times 10^6 \text{ m} - 6.38 \times 10^6 \text{ m} = 2.64 \times 10^6 \text{ m} \\ = 2.64 \times 10^3 \text{ km}$$

78. Two satellites of equal mass are put into orbit 30.0 m apart. The gravitational force between them is $2.0 \times 10^{-7} \text{ N}$.

a. What is the mass of each satellite?

$$F = G \frac{m_1 m_2}{r^2}, m_1 = m_2 = m$$

$$m = \sqrt{\frac{Fr^2}{G}} = \sqrt{\frac{(2.0 \times 10^{-7} \text{ N})(30.0 \text{ m})^2}{6.67 \times 10^{-11} \text{ N} \cdot \text{m}^2/\text{kg}^2}}$$

$$= 1.6 \times 10^3 \text{ kg}$$

b. What is the initial acceleration given to each satellite by gravitational force?

$$F_{\text{net}} = ma$$

$$a = \frac{F_{\text{net}}}{m} = \frac{2.0 \times 10^{-7} \text{ N}}{1.6 \times 10^3 \text{ kg}} = 1.3 \times 10^{-10} \text{ m/s}^2$$

79. Two large spheres are suspended close to each other. Their centers are 4.0 m apart, as shown in **Figure 7-25**. One sphere weighs $9.8 \times 10^2 \text{ N}$. The other sphere has a weight of $1.96 \times 10^2 \text{ N}$. What is the gravitational force between them?

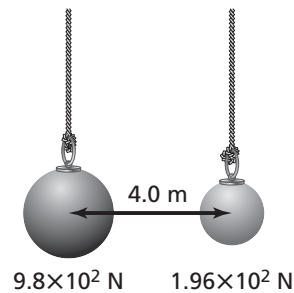

■ Figure 7-25

$$m_1 = \frac{F_g}{g} = \frac{9.8 \times 10^2 \text{ N}}{9.80 \text{ m/s}^2} = 1.0 \times 10^2 \text{ kg}$$

$$m_2 = \frac{F_g}{g} = \frac{1.96 \times 10^2 \text{ N}}{9.80 \text{ m/s}^2} = 2.00 \times 10^1 \text{ kg}$$

$$F = G \frac{m_1 m_2}{r^2}$$

$$= \frac{(6.67 \times 10^{-11} \text{ N} \cdot \text{m}^2/\text{kg}^2)(1.0 \times 10^1 \text{ kg})(2.00 \times 10^1 \text{ kg})}{(4.0 \text{ m})^2}$$

$$= 8.3 \times 10^{-9} \text{ N}$$

Chapter 7 continued

- 80.** Suppose the centers of Earth and the Moon are 3.9×10^8 m apart, and the gravitational force between them is about 1.9×10^{20} N. What is the approximate mass of the Moon?

$$F = G \frac{m_E m_M}{r^2}$$

$$m_M = \frac{Fr^2}{Gm_E}$$

$$= \frac{(1.9 \times 10^{20} \text{ N})(3.9 \times 10^8 \text{ m})^2}{(6.67 \times 10^{-11} \text{ N}\cdot\text{m}^2/\text{kg}^2)(5.97 \times 10^{24} \text{ kg})}$$

$$= 7.3 \times 10^{22} \text{ kg}$$

- 81.** On the surface of the Moon, a 91.0-kg physics teacher weighs only 145.6 N. What is the value of the Moon's gravitational field at its surface?

$$F_g = mg,$$

So $g = \frac{F_g}{m} = \frac{145.6 \text{ N}}{91.0 \text{ kg}} = 1.60 \text{ N/kg}$

Level 3

- 82.** The mass of an electron is 9.1×10^{-31} kg. The mass of a proton is 1.7×10^{-27} kg. An electron and a proton are about 0.59×10^{-10} m apart in a hydrogen atom. What gravitational force exists between the proton and the electron of a hydrogen atom?

$$F = G \frac{m_e m_p}{r^2}$$

$$= \frac{(6.67 \times 10^{-11} \text{ N}\cdot\text{m}^2/\text{kg}^2)(9.1 \times 10^{-31} \text{ kg})(1.7 \times 10^{-27} \text{ kg})}{(1.0 \times 10^{-10} \text{ m})^2}$$

$$= 1.0 \times 10^{-47} \text{ N}$$

- 83.** Consider two spherical 8.0-kg objects that are 5.0 m apart.
- a.** What is the gravitational force between the two objects?

$$F = G \frac{m_1 m_2}{r^2}$$

$$= \frac{(6.67 \times 10^{-11} \text{ N}\cdot\text{m}^2/\text{kg}^2)(8.0 \text{ kg})(8.0 \text{ kg})}{(5.0 \text{ m})^2}$$

$$= 1.7 \times 10^{-10} \text{ N}$$

- b.** What is the gravitational force between them when they are 5.0×10^1 m apart?

$$F = G \frac{m_1 m_2}{r^2}$$

$$= \frac{(6.67 \times 10^{-11} \text{ N}\cdot\text{m}^2/\text{kg}^2)(8.0 \text{ kg})(8.0 \text{ kg})}{(5.0 \times 10^1 \text{ m})^2}$$

$$= 1.7 \times 10^{-12} \text{ N}$$

Chapter 7 continued

- 84.** If you weigh 637 N on Earth's surface, how much would you weigh on the planet Mars? Mars has a mass of 6.42×10^{23} kg and a radius of 3.40×10^6 m.

$$m = \frac{F_g}{g} = \frac{637 \text{ N}}{9.80 \text{ m/s}^2} = 65.0 \text{ kg}$$

$$F = G \frac{m_1 m_2}{r^2}$$

$$= \frac{(6.67 \times 10^{-11} \text{ N}\cdot\text{m}^2/\text{kg}^2)(65.0 \text{ kg})(6.37 \times 10^{23} \text{ kg})}{(3.43 \times 10^6 \text{ m})^2}$$

$$= 235 \text{ N}$$

- 85.** Using Newton's version of Kepler's third law and information from Table 7-1 on page 173, calculate the period of Earth's Moon if the orbital radius were twice the actual value of 3.9×10^8 m.

$$T_M = \sqrt{\left(\frac{4\pi^2}{Gm_E}\right)(r^3)}$$

$$= \sqrt{\left(\frac{4\pi^2}{(6.67 \times 10^{-11} \text{ N}\cdot\text{m}^2/\text{kg}^2)(5.979 \times 10^{24} \text{ kg})}\right)(7.8 \times 10^8 \text{ m})^3}$$

$$= 6.85 \times 10^6 \text{ s or 79 days}$$

- 86.** Find the value of g , acceleration due to gravity, in the following situations.

- a.** Earth's mass is triple its actual value, but its radius remains the same.

$$g = \frac{Gm_E}{(r_E)^2} = 9.80 \text{ m/s}^2$$

$$2m_E \rightarrow 2g = 2(9.80 \text{ m/s}^2) = 19.6 \text{ m/s}^2$$

- b.** Earth's radius is tripled, but its mass remains the same.

$$g = \frac{Gm_E}{(r_E)^2} = 9.80 \text{ m/s}^2$$

$$2r_E \rightarrow \frac{g}{4} = \frac{9.80 \text{ m/s}^2}{4} = 2.45 \text{ m/s}^2$$

- c.** Both the mass and radius of Earth are doubled.

$$g = \frac{Gm_E}{(r_E)^2}$$

$$2m_E \text{ and } 2r_E \rightarrow \frac{2g}{4} = \frac{2(9.80 \text{ m/s}^2)}{4} = 4.90 \text{ m/s}^2$$

- 87. Astronaut** What would be the strength of Earth's gravitational field at a point where an 80.0-kg astronaut would experience a 25.0 percent reduction in weight?

$$F_g = mg = (80.0 \text{ kg})(9.80 \text{ m/s}^2) = 784 \text{ N}$$

$$F_{g, \text{ reduced}} = (784 \text{ N})(0.750) = 588 \text{ N}$$

$$g_{\text{reduced}} = \frac{F_{g, \text{ reduced}}}{m} = \frac{588 \text{ N}}{80.0 \text{ kg}} = 7.35 \text{ m/s}^2$$

Chapter 7 continued

Mixed Review

pages 193–194

Level 1

88. Use the information for Earth in Table 7-1 on page 173 to calculate the mass of the Sun, using Newton's version of Kepler's third law.

$$T^2 = \left(\frac{4\pi^2}{Gm} \right) r^3,$$

$$\text{so } mT^2 = \left(\frac{4\pi^2}{G} \right) r^3 \text{ and}$$

$$m = \left(\frac{4\pi^2}{G} \right) \frac{r^3}{T^2}$$

$$= \left(\frac{4\pi^2}{6.67 \times 10^{-11} \text{ N}\cdot\text{m}^2/\text{kg}^2} \right) \frac{(1.50 \times 10^{11} \text{ m})^3}{(3.156 \times 10^7 \text{ s})^2}$$

$$= 2.01 \times 10^{30} \text{ kg}$$

89. Earth's gravitational field is 7.83 N/kg at the altitude of the space shuttle. At this altitude, what is the size of the force of attraction between a student with a mass of 45.0 kg and Earth?

$$g = \frac{F}{m}$$

$$F = mg = (45.0 \text{ kg})(7.83 \text{ N/kg}) = 352 \text{ N}$$

90. Use the data from Table 7-1 on page 173 to find the speed and period of a satellite that orbits Mars 175 km above its surface.

$$r = r_M + 175 \text{ km} = 3.40 \times 10^6 \text{ m} + 0.175 \times 10^6 \text{ m}$$

$$= 3.58 \times 10^6 \text{ m}$$

$$v = \sqrt{\frac{GM_M}{r}}$$

$$= \sqrt{\frac{(6.67 \times 10^{-11} \text{ N}\cdot\text{m}^2/\text{kg}^2)(6.42 \times 10^{23} \text{ kg})}{3.58 \times 10^6 \text{ m}}}$$

$$= 3.46 \times 10^3 \text{ m/s}$$

$$T = 2\pi \sqrt{\frac{r^3}{GM_M}}$$

$$= 2\pi \sqrt{\frac{(3.58 \times 10^6 \text{ m})^3}{(6.67 \times 10^{-11} \text{ N}\cdot\text{m}^2/\text{kg}^2)(6.42 \times 10^{23} \text{ kg})}}$$

$$= 6.45 \times 10^3 \text{ s or } 1.79 \text{ h}$$

موقع
المنهج البحرينية
almanahj.com/bh

Chapter 7 continued

Level 2

- 91. Satellite** A satellite is placed in orbit, as shown in **Figure 7-26**, with a radius that is half the radius of the Moon's orbit. Find the period of the satellite in units of the period of the Moon.

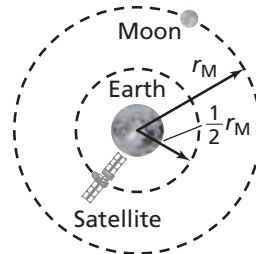

■ Figure 7-26

$$\left(\frac{T_s}{T_M}\right)^2 = \left(\frac{r_s}{r_M}\right)^3$$

$$\begin{aligned} \text{So, } T_s &= \sqrt{\left(\frac{r_s}{r_M}\right)^3 T_M^2} = \sqrt{\left(\frac{0.50r_M}{r_M}\right)^3 T_M^2} \\ &= \sqrt{0.125T_M^2} \\ &= 0.35T_M \end{aligned}$$

- 92. Cannonball** The Moon's mass is 7.3×10^{22} kg and its radius is 1785 km. If Newton's thought experiment of firing a cannonball from a high mountain were attempted on the Moon, how fast would the cannonball have to be fired? How long would it take the cannonball to return to the cannon?

$$\begin{aligned} v &= \sqrt{\frac{Gm}{r}} \\ &= \sqrt{\frac{(6.67 \times 10^{-11} \text{ N}\cdot\text{m}^2/\text{kg}^2)(7.3 \times 10^{22} \text{ kg})}{1.785 \times 10^6 \text{ m}}} \\ &= 1.7 \times 10^3 \text{ m/s} \end{aligned}$$

$$\begin{aligned} T &= 2\pi \sqrt{\frac{r^3}{Gm}} \\ &= 2\pi \sqrt{\frac{(1.785 \times 10^6 \text{ m})^3}{(6.67 \times 10^{-11} \text{ N}\cdot\text{m}^2/\text{kg}^2)(7.3 \times 10^{22} \text{ kg})}} \\ &= 6.8 \times 10^3 \text{ s} \end{aligned}$$

- 93.** The period of the Moon is one month. Answer the following questions assuming that the mass of Earth is doubled.

- a.** What would the period of the Moon be? Express your results in months.

$$T = 2\pi \sqrt{\frac{r^3}{Gm}}$$

So, if Earth's mass were doubled, but the radius remained the same, then the period would be reduced by a factor of $\frac{1}{\sqrt{2}}$, or 0.707 months.

Chapter 7 continued

- b. Where would a satellite with an orbital period of one month be located?

$$\left(\frac{T}{2\pi}\right)^2 = \frac{r^3}{Gm}$$

$$r^3 = \left(\frac{T}{2\pi}\right)^2 (Gm)$$

Thus, r^3 would be doubled, or r would be increased by $2^{\frac{1}{3}} = 1.26$ times the present radius of the Moon.

- c. How would the length of a year on Earth be affected?

The length of a year on Earth would not be affected. It does not depend on Earth's mass.

Level 3

94. How fast would a planet of Earth's mass and size have to spin so that an object at the equator would be weightless? Give the period of rotation of the planet in minutes.

The centripetal acceleration must equal the acceleration due to gravity so that the surface of the planet would not have to supply any force (otherwise known as weight).

$$\frac{mv^2}{r} = G \frac{m_E m}{r^2}$$

$$v = \sqrt{\frac{Gm_E}{r}}$$

$$\text{But, } v = \frac{2\pi r}{T}, \text{ so } T = \frac{2\pi r}{v} = \frac{2\pi r}{\sqrt{\frac{Gm_E}{r}}}$$

$$= 2\pi \sqrt{\frac{r^3}{Gm_E}}$$

$$= 2\pi \sqrt{\frac{(6.38 \times 10^6 \text{ m})^3}{(6.67 \times 10^{-11} \text{ N}\cdot\text{m}^2/\text{kg}^2)(5.97 \times 10^{24} \text{ kg})}}$$

$$= 5.07 \times 10^3 \text{ s} = 84.5 \text{ min}$$

95. **Car Races** Suppose that a Martian base has been established and car races are being considered. A flat, circular race track has been built for the race. If a car can achieve speeds of up to 12 m/s, what is the smallest radius of a track for which the coefficient of friction is 0.50?

The force that causes the centripetal acceleration is the static friction force:

$$F_{\text{static}} \leq \mu_s mg$$

$$\text{The centripetal acceleration is } a_c = \frac{v^2}{r}$$

$$\text{So, } \frac{mv^2}{r} \leq \mu_s mg$$

$$\text{Thus, } r \geq \frac{v^2}{\mu_s g}$$

$$\text{Note that } g = \frac{Gm}{(r_{\text{planet}})^2}$$

Chapter 7 continued

To find g on Mars, the following calculation is used.

$$m_{\text{Mars}} = 6.37 \times 10^{23} \text{ kg, and } R_{\text{Mars}} = 3.43 \times 10^6 \text{ m}$$

$$\text{So, } g_{\text{Mars}} = 3.61 \text{ m/s}^2$$

$$\text{Therefore, } R \geq \frac{(12 \text{ m/s})^2}{(0.50)(3.61 \text{ m/s}^2)}$$

$$R \geq 8.0 \times 10^1 \text{ m}$$

96. **Apollo 11** On July 19, 1969, *Apollo 11*'s revolution around the Moon was adjusted to an average orbit of 111 km. The radius of the Moon is 1785 km, and the mass of the Moon is 7.3×10^{22} kg.

- a. How many minutes did *Apollo 11* take to orbit the Moon once?

$$r_{\text{orbit}} = 1785 \times 10^3 \text{ m} + 111 \times 10^3 \text{ m}$$

$$T = 2\pi \sqrt{\frac{r^3}{Gm}}$$

$$= 2\pi \sqrt{\frac{(1896 \times 10^3 \text{ m})^3}{(6.67 \times 10^{-11} \text{ N}\cdot\text{m}^2/\text{kg}^2)(7.3 \times 10^{22} \text{ kg})}}$$

$$= 7.4 \times 10^3 \text{ s}$$

$$= 1.2 \times 10^2 \text{ min}$$

- b. At what velocity did *Apollo 11* orbit the Moon?

$$v = \sqrt{\frac{Gm}{r_{\text{orbit}}}}$$

$$= \sqrt{\frac{(6.67 \times 10^{-11} \text{ N}\cdot\text{m}^2/\text{kg}^2)(7.3 \times 10^{22} \text{ kg})}{1896 \times 10^3 \text{ m}}}$$

$$= 1.6 \times 10^3 \text{ m/s}$$

Thinking Critically

page 194

97. **Analyze and Conclude** Some people say that the tides on Earth are caused by the pull of the Moon. Is this statement true?

- a. Determine the forces that the Moon and the Sun exert on a mass, m , of water on Earth. Your answer will be in terms of m with units of N.

$$F_{S, m} = 6.67 \times 10^{-11} \text{ N}\cdot\text{m}^2/\text{kg}^2 \left(\frac{(1.99 \times 10^{30} \text{ kg})(m)}{(1.50 \times 10^{11} \text{ m})^2} \right)$$

$$= (5.90 \times 10^{-3} \text{ N})m$$

$$F_{M, m} = 6.67 \times 10^{-11} \text{ N}\cdot\text{m}^2/\text{kg}^2 \left(\frac{(7.36 \times 10^{22} \text{ kg})(m)}{(3.80 \times 10^8 \text{ m})^2} \right)$$

$$= (3.40 \times 10^{-5} \text{ N})m$$

- b. Which celestial body, the Sun or the Moon, has a greater pull on the waters of Earth?

The Sun pulls approximately 100 times stronger on the waters of Earth.

Chapter 7 continued

- c. Determine the difference in force exerted by the Moon on the water at the near surface and the water at the far surface (on the opposite side) of Earth, as illustrated in **Figure 7-27**. Again, your answer will be in terms of m with units of N.

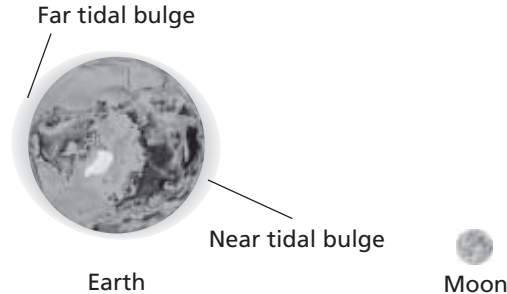

■ **Figure 7-27** (Not to scale)

موقع
المنهج البحرينية
almanahj.com/

$$F_{m, mA} - F_{m, mB} = (6.67 \times 10^{-11} \text{ N} \cdot \text{m}^2/\text{kg}^2)(7.36 \times 10^{22} \text{ kg})(m) \left(\frac{1}{(3.80 \times 10^8 \text{ m} - 6.37 \times 10^6 \text{ m})^2} - \frac{1}{(3.80 \times 10^8 \text{ m} + 6.37 \times 10^6 \text{ m})^2} \right)$$

$$= (2.28 \times 10^{-6} \text{ N})m$$

- d. Determine the difference in force exerted by the Sun on water at the near surface and on water at the far surface (on the opposite side) of Earth.

$$F_{S, mA} - F_{S, mB} = (6.67 \times 10^{-11} \text{ N} \cdot \text{m}^2/\text{kg}^2)(1.99 \times 10^{30} \text{ kg})(m) \left(\frac{1}{(1.50 \times 10^{11} \text{ m} - 6.37 \times 10^6 \text{ m})^2} - \frac{1}{(1.50 \times 10^{11} \text{ m} + 6.37 \times 10^6 \text{ m})^2} \right)$$

$$= (1.00 \times 10^{-6} \text{ N})m$$

- e. Which celestial body has a greater difference in pull from one side of Earth to the other?

the Moon

- f. Why is the statement that the tides result from the pull of the Moon misleading? Make a correct statement to explain how the Moon causes tides on Earth.

The tides are primarily due to the difference between the pull of the Moon on Earth's near side and Earth's far side.

- 98. Make and Use Graphs** Use Newton's law of universal gravitation to find an equation where x is equal to an object's distance from Earth's center, and γ is its acceleration due to gravity. Use a graphing calculator to graph this equation, using 6400–6600 km as the range for x and 9–10 m/s² as the range for γ . The equation should be of the form $\gamma = c(1/x^2)$. Trace along this graph and find γ for the following locations.

- a. at sea level, 6400 km

$$c = (Gm_E)(10^6 \text{ m}^2/\text{km}^2) = 4.0 \times 10^8 \text{ units}$$

$$\text{acc} = 9.77 \text{ m/s}^2$$

- b. on top of Mt. Everest, 6410 km

$$9.74 \text{ m/s}^2$$

Chapter 7 continued

- c. in a typical satellite orbit, 6500 km
 9.47 m/s^2
- d. in a much higher orbit, 6600 km
 9.18 m/s^2

Writing in Physics

page 194

99. Research and describe the historical development of the measurement of the distance between the Sun and Earth.

One of the earliest crude measurements was made by James Bradley in 1732. The answers also should discuss measurements of the transits of Venus done in the 1690s.

100. Explore the discovery of planets around other stars. What methods did the astronomers use? What measurements did they take? How did they use Kepler's third law?

Astronomers measure the star's tiny velocity due to the gravitational force exerted on it by a massive planet. The velocity is calculated by measuring the Doppler shift of the star's light that results from that motion. The velocity oscillates back and forth as the planets orbit the star, allowing calculation of the planet's period. From the size of the velocity they can estimate the planet's distance and mass. By comparing the distances and periods of planets in solar systems with multiple planets and using Kepler's third law, astronomers can better separate the distances and masses of stars and planets.

Cumulative Review

page 194

101. **Airplanes** A jet airplane took off from Pittsburgh at 2:20 P.M. and landed in Washington, DC, at 3:15 P.M. on the same day. If the jet's average speed while in the air was 441.0 km/h, what is the distance between the cities? (Chapter 2)

$$\Delta t = 55 \text{ min} = 0.917 \text{ h}$$

$$\bar{v} = \frac{\Delta d}{\Delta t}$$

$$\begin{aligned}\Delta d &= \bar{v}\Delta t \\ &= (441.0 \text{ km/h})(0.917 \text{ h}) \\ &= 404 \text{ km}\end{aligned}$$

102. Carolyn wants to know how much her brother Jared weighs. He agrees to stand on a scale for her, but only if they are riding in an elevator. If he steps on the scale while the elevator is accelerating upward at 1.75 m/s^2 and the scale reads 716 N, what is Jared's usual weight on Earth? (Chapter 4)

Identify Jared as the system and upward as positive.

$$\begin{aligned}F_{\text{net}} &= F_{\text{scale on Jared}} - F_{\text{Earth's mass on Jared}} \\ &= ma\end{aligned}$$

Chapter 7 continued

$$F_{\text{scale on Jared}} = F_{\text{Earth's mass on Jared}} + \left(\frac{F_{\text{Earth's mass on Jared}}}{g} \right) a$$

$$= F_{\text{Earth's mass on Jared}} \left(1 + \frac{a}{g} \right)$$

$$F_{\text{Earth's mass on Jared}} = \frac{F_{\text{scale on Jared}}}{\left(1 + \frac{a}{g} \right)}$$

$$= \frac{716 \text{ N}}{\left(1 + \frac{1.75 \text{ m/s}^2}{9.80 \text{ m/s}^2} \right)}$$

$$= 608 \text{ N}$$

103. Potato Bug A 1.0-g potato bug is walking around the outer rim of an upside-down flying disk. If the disk has a diameter of 17.2 cm and the bug moves at a rate of 0.63 cm/s, what is the centripetal force acting on the bug? What agent provides this force? (Chapter 6)

$$F_c = \frac{mv^2}{r} = \frac{(0.0010 \text{ kg})(0.0063 \text{ cm})^2}{0.086 \text{ m}} = 5.0 \times 10^{-7} \text{ N,}$$

provided by the frictional force between the bug and the flying disk

Challenge Problem

page 176

Astronomers have detected three planets that orbit the star Upsilon Andromedae. Planet B has an average orbital radius of 0.059 AU and a period of 4.6170 days. Planet C has an average orbital radius of 0.829 AU and a period of 241.5 days. Planet D has an average orbital radius of 2.53 AU and a period of 1284 days. (Distances are given in astronomical units (AU)—Earth's average distance from the Sun. The distance from Earth to the Sun is 1.00 AU.)

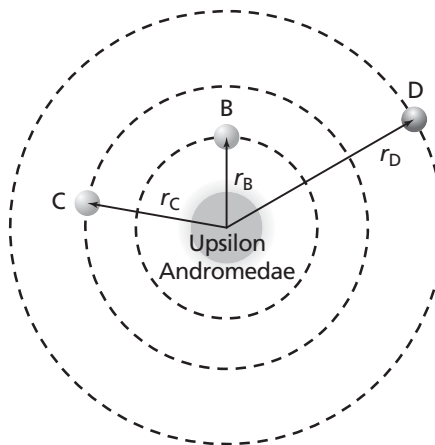

- Do these planets obey Kepler's third law?

Test by calculating the following ratio $\frac{r^3}{T^2}$.

$$\text{For planet B, } \frac{r_B^3}{T_B^2} = \frac{(0.059 \text{ AU})^3}{(4.6170 \text{ days})^2} = 9.6 \times 10^{-6} \text{ AU}^3/\text{days}^2$$

Chapter 7 continued

$$\text{For planet C, } \frac{r_C^3}{T_C^2} = \frac{(0.829 \text{ AU})^3}{(241.5 \text{ days})^2} = 9.77 \times 10^{-6} \text{ AU}^3/\text{days}^2$$

$$\text{For planet D, } \frac{r_D^3}{T_D^2} = \frac{(2.53 \text{ AU})^3}{(1284 \text{ days})^2} = 9.82 \times 10^{-6} \text{ AU}^3/\text{days}^2$$

These values are quite close, so Kepler's third law is obeyed.

2. Find the mass of the star Upsilon Andromedae in units of the Sun's mass.

$$\frac{r^3}{T^2} = \frac{Gm_{\text{central body}}}{4\pi^2}$$

$$\text{For the Earth-Sun system, } \frac{r^3}{T^2} = \frac{(1.000 \text{ AU})^3}{(1.000 \text{ y})^2} = 1.000 \text{ AU}^3/\text{y}^2$$

For the planet C-Upsilon system,

$$\frac{r^3}{T^2} = 9.77 \times 10^{-6} \text{ AU}^3/\text{days}^2$$

$$= (9.77 \times 10^{-6} \text{ AU}^3/\text{days}^2)(365 \text{ days/y})^2 = 1.30 \text{ AU}^3/\text{y}^2$$

$$= \frac{Gm_{\text{star}}}{4\pi^2}$$

The ratio of the two shows the star's slightly heavier mass to be 1.30 that of the Sun.

Practice Problems

8.1 Describing Rotational Motion

pages 197–200

page 200

1. What is the angular displacement of each of the following hands of a clock in 1 h? State your answer in three significant digits.

a. the second hand

$$\Delta\theta = (60)(-2\pi \text{ rad})$$

$$= -120\pi \text{ rad or } -377 \text{ rad}$$

b. the minute hand

$$\Delta\theta = -2\pi \text{ rad or } -6.28 \text{ rad}$$

c. the hour hand

$$\Delta\theta = \left(\frac{1}{12}\right)(-2\pi \text{ rad})$$

$$= \frac{-\pi}{6} \text{ rad or } 0.524 \text{ rad}$$

2. If a truck has a linear acceleration of 1.85 m/s^2 and the wheels have an angular acceleration of 5.23 rad/s^2 , what is the diameter of the truck's wheels?

$$r = \frac{a}{\alpha}$$

$$= \frac{1.85 \text{ m/s}^2}{5.23 \text{ rad/s}^2}$$

$$= 0.354 \text{ m}$$

Thus, the diameter is **0.707 m**.

3. The truck in the previous problem is towing a trailer with wheels that have a diameter of 48 cm.

a. How does the linear acceleration of the trailer compare with that of the truck?

The changes in velocity are the same, so the linear accelerations are the same.

b. How do the angular accelerations of the wheels of the trailer and the wheels of the truck compare?

Because the radius of the wheel is reduced from 35.4 cm to 24 cm, the angular acceleration will be increased.

$$\alpha_1 = 5.23 \text{ rad/s}^2$$

$$\alpha_2 = \frac{a_2}{r} = \frac{1.85 \text{ m/s}^2}{0.24 \text{ m}}$$

$$= 7.7 \text{ rad/s}^2$$

4. You want to replace the tires on your car with tires that have a larger diameter. After you change the tires, for trips at the same speed and over the same distance, how will the angular velocity and number of revolutions change?

Because $\omega = \frac{v}{r}$, if r is increased, ω will decrease. The number of revolutions will also decrease.

Section Review

8.1 Describing Rotational Motion

pages 197–200

page 200

5. **Angular Displacement** A movie lasts 2 h. During that time, what is the angular displacement of each of the following?

a. the hour hand

$$\Delta\theta = \left(\frac{1}{6}\right)(-2\pi \text{ rad}) = \frac{-\pi}{3} \text{ rad}$$

b. the minute hand

$$\Delta\theta = (2)(-2\pi \text{ rad}) = -4\pi \text{ rad}$$

6. **Angular Velocity** The Moon rotates once on its axis in 27.3 days. Its radius is $1.74 \times 10^6 \text{ m}$.

Chapter 8 continued

- a. What is the period of the Moon's rotation in seconds?

$$\begin{aligned}\text{period} &= (27.3 \text{ day})(24 \text{ h/day}) \\ &\quad (3600 \text{ s/h}) \\ &= 2.36 \times 10^6 \text{ s}\end{aligned}$$

- b. What is the frequency of the Moon's rotation in rad/s?

$$\begin{aligned}\omega &= \frac{1}{\text{period}} \\ &= \frac{1}{2.36 \times 10^6} \text{ rev/s, or} \\ &\quad 2.66 \times 10^{-6} \text{ rad/s}\end{aligned}$$

- c. What is the linear speed of a rock on the Moon's equator due only to the Moon's rotation

$$\begin{aligned}v &= r\omega \\ &= (1.74 \times 10^6 \text{ m})(2.66 \times 10^{-6} \text{ rad/s}) \\ &= 4.63 \text{ m/s}\end{aligned}$$

- d. Compare this speed with the speed of a person on Earth's equator due to Earth's rotation.

The speed on Earth's equator is 464 m/s, or about 100 times faster.

7. **Angular Displacement** The ball in a computer mouse is 2.0 cm in diameter. If you move the mouse 12 cm, what is the angular displacement of the ball?

$$d = r\theta$$

$$\text{so } \theta = \frac{d}{r} = \frac{12 \text{ cm}}{1.0 \text{ cm}} = 12 \text{ rad}$$

8. **Angular Displacement** Do all parts of the minute hand on a watch have the same angular displacement? Do they move the same linear distance? Explain.

angular displacement—yes; linear distance—no, because linear distance is a function of the radius

9. **Angular Acceleration** In the spin cycle of a clothes washer, the drum turns at 635 rev/min. If the lid of the washer is opened, the motor is turned off. If the drum requires 8.0 s to slow to a stop, what is the angular acceleration of the drum?

$$\omega_i = 635 \text{ rpm} = 66.53 \text{ rad/s}$$

$$\omega_f = 0.0, \text{ so } \Delta\omega = -66.5 \text{ rad/s}$$

$$\text{and } \alpha = \frac{\Delta\omega}{\Delta t} = \frac{-66.5 \text{ rad/s}}{8.0 \text{ s}} = -8.3 \text{ rad/s}^2$$

10. **Critical Thinking** A CD-ROM has a spiral track that starts 2.7 cm from the center of the disk and ends 5.5 cm from the center. The disk drive must turn the disk so that the linear velocity of the track is a constant 1.4 m/s. Find the following.

- a. the angular velocity of the disk (in rad/s and rev/min) for the start of the track

$$\begin{aligned}\omega &= \frac{v}{r} \\ &= \frac{1.4 \text{ m/s}}{0.027 \text{ m}} \\ &= 52 \text{ rad/s or } 5.0 \times 10^2 \text{ rev/min}\end{aligned}$$

- b. the disk's angular velocity at the end of the track

$$\begin{aligned}\omega &= \frac{v}{r} \\ &= \frac{1.4 \text{ m/s}}{0.055 \text{ m}} \\ &= 25 \text{ rad/s or } 2.4 \times 10^2 \text{ rev/min}\end{aligned}$$

- c. the disk's angular acceleration if the disk is played for 76 min

$$\begin{aligned}\alpha &= \frac{\Delta\omega}{\Delta t} = \frac{\omega_f - \omega_i}{\Delta t} \\ &= \frac{-25 \text{ rad/s} - 52 \text{ rad/s}}{(76 \text{ min})(60 \text{ s/min})} \\ &= -5.9 \times 10^{-3} \text{ rad/s}^2\end{aligned}$$

Practice Problems

8.2 Rotational Dynamics pages 201–210

page 203

11. Consider the wrench in Example Problem 1. What force is needed if it is applied to the wrench at a point perpendicular to the wrench?

$$\tau = Fr \sin \theta$$

$$\text{so } F = \frac{\tau}{r \sin \theta}$$

$$= \frac{35 \text{ N}\cdot\text{m}}{(0.25 \text{ m})(\sin 90.0^\circ)}$$

$$= 1.4 \times 10^2 \text{ N}$$

12. If a torque of 55.0 N·m is required and the largest force that can be exerted by you is 135 N, what is the length of the lever arm that must be used?

For the shortest possible lever arm, $\theta = 90.0^\circ$.

$$\tau = Fr \sin \theta$$

$$\text{so } r = \frac{\tau}{F \sin \theta}$$

$$= \frac{55.0 \text{ N}\cdot\text{m}}{(135 \text{ N})(\sin 90.0^\circ)}$$

$$= 0.407 \text{ m}$$

13. You have a 0.234-m-long wrench. A job requires a torque of 32.4 N·m, and you can exert a force of 232 N. What is the smallest angle, with respect to the vertical, at which the force can be exerted?

$$\tau = Fr \sin \theta$$

$$\text{so } \theta = \sin^{-1}\left(\frac{\tau}{Fr}\right)$$

$$= \sin^{-1}\left(\frac{32.4 \text{ N}\cdot\text{m}}{(232 \text{ N})(0.234 \text{ m})}\right)$$

$$= 36.6^\circ$$

14. You stand on the pedal of a bicycle. If you have a mass of 65 kg, the pedal makes an angle of 35° above the horizontal, and the pedal is 18 cm from the center of the chain ring, how much torque would you exert?

The angle between the force and the radius is $90^\circ - 35^\circ = 55^\circ$.

$$\tau = Fr \sin \theta$$

$$= mgr \sin \theta$$

$$= (65 \text{ kg})(9.80 \text{ m/s}^2)(0.18 \text{ m})(\sin 55^\circ)$$

$$= 94 \text{ N}\cdot\text{m}$$

15. If the pedal in problem 14 is horizontal, how much torque would you exert? How much torque would you exert when the pedal is vertical?

Horizontal $\theta = 90.0^\circ$

$$\text{so } \tau = Fr \sin \theta$$

$$= mgr \sin \theta$$

$$= (65 \text{ kg})(9.80 \text{ m/s}^2)(0.18 \text{ m})(\sin 90.0^\circ)$$

$$= 1.1 \times 10^2 \text{ N}\cdot\text{m}$$

Vertical $\theta = 0.0^\circ$

$$\text{So } \tau = Fr \sin \theta$$

$$= mgr \sin \theta$$

$$= (65 \text{ kg})(9.80 \text{ m/s}^2)(0.18 \text{ m})(\sin 0.0^\circ)$$

$$= 0.0 \text{ N}\cdot\text{m}$$

page 205

16. Ashok, whose mass is 43 kg, sits 1.8 m from the center of a seesaw. Steve, whose mass is 52 kg, wants to balance Ashok. How far from the center of the seesaw should Steve sit?

$$F_A r_A = F_S r_S$$

$$\text{so } r_S = \frac{F_A r_A}{F_S}$$

$$= \frac{m_A g r_A}{m_S g}$$

$$= \frac{m_A r_A}{m_S}$$

$$= \frac{(43 \text{ kg})(1.8 \text{ m})}{52 \text{ kg}}$$

$$= 1.5 \text{ m}$$

17. A bicycle-chain wheel has a radius of 7.70 cm. If the chain exerts a 35.0-N force on the wheel in the clockwise direction, what torque is needed to keep the wheel from turning?

Chapter 8 continued

$$\begin{aligned}\tau_{\text{chain}} &= F_g r \\ &= (-35.0 \text{ N})(0.0770 \text{ m}) \\ &= -2.70 \text{ N}\cdot\text{m}\end{aligned}$$

Thus, a torque of +2.70 N·m must be exerted to balance this torque.

18. Two baskets of fruit hang from strings going around pulleys of different diameters, as shown in **Figure 8-6**. What is the mass of basket A?

$$\tau_1 = \tau_2$$

$$F_1 r_1 = F_2 r_2$$

$$m_1 g r_1 = m_2 g r_2$$

$$m_1 = \frac{m_2 r_2}{r_1}$$

$$= \frac{(0.23 \text{ kg})(1.1 \text{ cm})}{4.5 \text{ cm}}$$

$$= 0.056 \text{ kg}$$

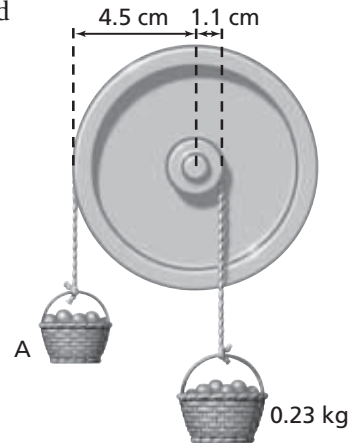

■ Figure 8-6

19. Suppose the radius of the larger pulley in problem 18 was increased to 6.0 cm. What is the mass of basket A now?

$$m_1 = \frac{m_2 r_2}{r_1}$$

$$= \frac{(0.23 \text{ kg})(1.1 \text{ cm})}{6.0 \text{ cm}}$$

$$= 0.042 \text{ kg}$$

20. A bicyclist, of mass 65.0 kg, stands on the pedal of a bicycle. The crank, which is 0.170 m long, makes a 45.0° angle with the vertical, as shown in **Figure 8-7**. The crank is attached to the chain wheel, which has a radius of 9.70 cm. What force must the chain exert to keep the wheel from turning?

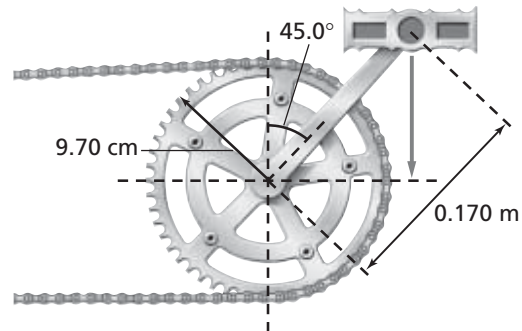

■ Figure 8-7

$$\tau_{\text{cr}} = -\tau_{\text{ch}}$$

$$F_{\text{cr}} r_{\text{cr}} \sin \theta = -F_{\text{ch}} r_{\text{ch}}$$

$$\text{so } F_{\text{ch}} = \frac{-F_{\text{cr}} r_{\text{cr}} \sin \theta}{r_{\text{ch}}}$$

$$= \frac{-m g r_{\text{cr}} \sin \theta}{r_{\text{ch}}}$$

$$= \frac{-(65.0 \text{ kg})(9.80 \text{ m/s}^2)(0.170 \text{ m})(\sin 45.0^\circ)}{0.097 \text{ m}}$$

$$= 789 \text{ N}$$

Chapter 8 continued

page 208

21. Two children of equal masses sit 0.3 m from the center of a seesaw. Assuming that their masses are much greater than that of the seesaw, by how much is the moment of inertia increased when they sit 0.6 m from the center?

For the mass of the two children, $I = mr^2 + mr^2 = 2mr^2$.

When r is doubled, I is multiplied by a factor of 4.

22. Suppose there are two balls with equal diameters and masses. One is solid, and the other is hollow, with all its mass distributed at its surface. Are the moments of inertia of the balls equal? If not, which is greater?

The more of the mass that is located far from the center, the greater the moment of inertia. Thus, the hollow ball has a greater value of I .

23. Figure 8-9 shows three massive spheres on a rod of very small mass. Consider the moment of inertia of the system, first when it is rotated about sphere A, and then when it is rotated about sphere C. Are the moments of inertia the same or different? Explain. If the moments of inertia are different, in which case is the moment of inertia greater?

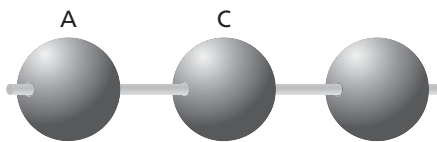

■ Figure 8-9

The moments of inertia are different. If the spacing between spheres is r and each sphere has mass m , then rotation about sphere A is

$$I = mr^2 + m(2r)^2 = 5mr^2.$$

Rotation about sphere C is

$$I = mr^2 + mr^2 = 2mr^2.$$

The moment of inertia is greater when rotating around sphere A.

24. Each sphere in the previous problem has a mass of 0.10 kg. The distance between spheres A and C is 0.20 m. Find the moment of inertia in the following instances: rotation about sphere A, rotation about sphere C.

About sphere A:

$$\begin{aligned} I &= mr^2 + m(2r)^2 \\ &= 5mr^2 \\ &= (5)(0.10 \text{ kg})(0.20 \text{ m})^2 \\ &= 0.020 \text{ kg}\cdot\text{m}^2 \end{aligned}$$

About sphere C:

$$\begin{aligned} I &= mr^2 + mr^2 \\ &= 2mr^2 \\ &= (2)(0.10 \text{ kg})(0.20 \text{ m})^2 \\ &= 0.0080 \text{ kg}\cdot\text{m}^2 \end{aligned}$$

page 210

25. Consider the wheel in Example Problem 4. If the force on the strap were twice as great, what would be the speed of rotation of the wheel after 15 s?

Torque is now twice as great. The angular acceleration is also twice as great, so the change in angular velocity is twice as great. Thus, the final angular velocity is 32π rad/s, or 16 rev/s.

26. A solid wheel accelerates at 3.25 rad/s^2 when a force of 4.5 N exerts a torque on it. If the wheel is replaced by a wheel with all of its mass on the rim, the moment of inertia is given by $I = mr^2$. If the same angular velocity were desired, what force would have to be exerted on the strap?

The angular acceleration has not changed, but the moment of inertia is twice as great. Therefore, the torque must be twice as great. The radius of the wheel is the same, so the force must be twice as great, or 9.0 N.

Chapter 8 continued

27. A bicycle wheel can be accelerated either by pulling on the chain that is on the gear or by pulling on a string wrapped around the tire. The wheel's radius is 0.38 m, while the radius of the gear is 0.14 m. If you obtained the needed acceleration with a force of 15 N on the chain, what force would you need to exert on the string?

The torque on the wheel comes from either the chain or the string.

$$\tau_{\text{chain}} = I_{\text{wheel}}\alpha_{\text{wheel}}$$

$$\tau_{\text{wheel}} = I_{\text{wheel}}\alpha_{\text{wheel}}$$

Thus, $\tau_{\text{chain}} = \tau_{\text{wheel}}$

$$F_{\text{chain}}r_{\text{gear}} = F_{\text{string}}r_{\text{wheel}}$$

$$F_{\text{string}} = \frac{F_{\text{chain}}r_{\text{gear}}}{r_{\text{wheel}}}$$

$$= \frac{(15 \text{ N})(0.14 \text{ m})}{0.38 \text{ m}}$$

$$= 5.5 \text{ N}$$

28. The bicycle wheel in problem 27 is used with a smaller gear whose radius is 0.11 m. The wheel can be accelerated either by pulling on the chain that is on the gear or by pulling string that is wrapped around the tire. If you obtained the needed acceleration with a force of 15 N on the chain, what force would you need to exert on the string?

$$F_{\text{string}} = \frac{F_{\text{chain}}r_{\text{gear}}}{r_{\text{wheel}}}$$

$$= \frac{(15 \text{ N})(0.11 \text{ m})}{0.38 \text{ m}}$$

$$= 4.3 \text{ N}$$

29. A disk with a moment of inertia of $0.26 \text{ kg}\cdot\text{m}^2$ is attached to a smaller disk mounted on the same axle. The smaller disk has a diameter of 0.180 m and a mass of 2.5 kg. A strap is wrapped around the smaller disk, as shown in **Figure 8-10**. Find the force needed to give this system an angular acceleration of 2.57 rad/s^2 .

$$\alpha = \frac{\tau}{I} = \frac{Fr}{I}$$

so $F = \frac{I\alpha}{r}$

$$= \frac{(I_{\text{small}} + I_{\text{large}})\alpha}{r}$$

$$= \frac{\left(\frac{1}{2}m_{\text{small}}r_{\text{small}}^2 + I_{\text{large}}\right)\alpha}{r}$$

$$= \frac{\left(\left(\frac{1}{2}\right)(2.5 \text{ kg})(0.090 \text{ m})^2 + 0.26 \text{ kg}\cdot\text{m}^2\right)(2.57 \text{ rad/s}^2)}{0.090 \text{ m}}$$

$$= 7.7 \text{ N}$$



■ Figure 8-10

Section Review

8.2 Rotational Dynamics
pages 201–210

page 210

- 30. Torque** Vijesh enters a revolving door that is not moving. Explain where and how Vijesh should push to produce a torque with the least amount of force.

To produce a torque with the least force, you should push as close to the edge as possible and at right angles to the door.

- 31. Lever Arm** You try to open a door, but you are unable to push at a right angle to the door. So, you push the door at an angle of 55° from the perpendicular. How much harder would you have to push to open the door just as fast as if you were to push it at 90° ?

The angle between the force and the radius is 35° . Torque is $\tau = Fr \sin \theta$. Because $\sin 90^\circ = 1$, and $\sin 35^\circ = 0.57$, you would have to increase the force by a ratio of $\frac{1}{0.57} = 1.75$ to obtain the same torque.

- 32. Net Torque** Two people are pulling on ropes wrapped around the edge of a large wheel. The wheel has a mass of 12 kg and a diameter of 2.4 m. One person pulls in a clockwise direction with a 43-N force, while the other pulls in a counterclockwise direction with a 67-N force. What is the net torque on the wheel?

$$\begin{aligned}\tau_{\text{net}} &= \tau_1 + \tau_2 \\ &= F_1 r + F_2 r \\ &= (F_1 + F_2) \left(\frac{1}{2} d \right) \\ &= (-43 \text{ N} + 67 \text{ N}) \left(\frac{1}{2} \right) (2.4 \text{ m}) \\ &= 29 \text{ N}\cdot\text{m}\end{aligned}$$

- 33. Moment of Inertia** Refer to Table 8-2 on page 206 and rank the moments of inertia from least to greatest of the following objects: a sphere, a wheel with almost all of its mass at the rim, and a solid disk. All have equal masses and diameters. Explain the advantage of using the one with the least moment of inertia.

from least to greatest: sphere $\left(\frac{2}{5} mr^2\right)$,

solid disk $\left(\frac{1}{2} mr^2\right)$, wheel (mr^2)

The less the moment of inertia, the less torque needed to give an object the same angular acceleration.

- 34. Newton's Second Law for Rotational Motion** A rope is wrapped around a pulley and pulled with a force of 13.0 N. The pulley's radius is 0.150 m. The pulley's rotational speed goes from 0.0 to 14.0 rev/min in 4.50 s. What is the moment of inertia of the pulley?

$$\begin{aligned}I &= \frac{\tau}{\alpha} \\ &= \frac{Fr}{\frac{\Delta\omega}{\Delta t}} \\ &= \frac{Fr\Delta t}{\omega_f - \omega_i} \\ &= \frac{(13.0 \text{ N})(0.150 \text{ m})(4.50 \text{ s})}{\left(14.0 \frac{\text{rev}}{\text{min}} - 0.0 \frac{\text{rev}}{\text{min}}\right) \left(\frac{2\pi \text{ rad}}{\text{rev}}\right) \left(\frac{\text{min}}{60 \text{ s}}\right)} \\ &= 5.99 \text{ kg}\cdot\text{m}^2\end{aligned}$$

- 35. Critical Thinking** A ball on an extremely low-friction, tilted surface, will slide downhill without rotating. If the surface is rough, however, the ball will roll. Explain why, using a free-body diagram.

Chapter 8 continued

Torque: $\tau = Fr \sin \theta$. The force is due to friction, and the torque causes the ball to rotate clockwise. If the surface is friction-free, then there is no force parallel to the surface, no torque, and thus no rotation. Remember, forces acting on the pivot point (the center of the ball) are ignored.

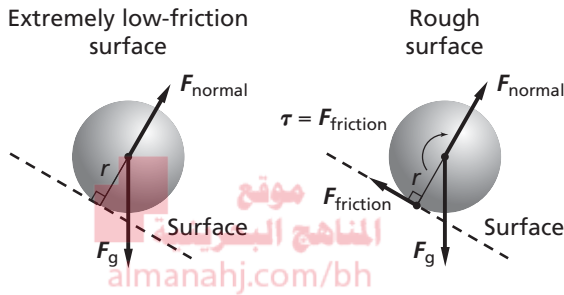

Practice Problems

8.3 Equilibrium pages 211–217

page 215

36. What would be the forces exerted by the two sawhorses if the ladder in Example Problem 5 had a mass of 11.4 kg?

Because no distances have changed, the equations are still valid:

$$F_B = \frac{r_g mg}{r_B}$$

$$F_B = \frac{(0.30 \text{ m})(11.4 \text{ kg})(9.80 \text{ m/s}^2)}{1.05 \text{ m}} = 32 \text{ N}$$

$$F_A = mg \left(1 - \frac{r_g}{r_B}\right)$$

$$= (11.4 \text{ kg})(9.80 \text{ m/s}^2) \left(1 - \frac{0.30 \text{ m}}{1.05 \text{ m}}\right)$$

$$= 8.0 \times 10^1 \text{ N}$$

37. A 7.3-kg ladder, 1.92 m long, rests on two sawhorses, as shown in **Figure 8-15**. Sawhorse A, on the left, is located 0.30 m from the end, and sawhorse B, on the right, is located 0.45 m from the other end. Choose the axis of rotation to be the center of mass of the ladder.

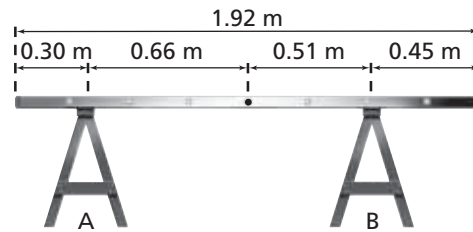

■ Figure 8-15

- a. What are the torques acting on the ladder?

$$\begin{aligned} \text{clockwise: } \tau_A &= F_A r_A \\ &= -F_A(0.96 \text{ m} - 0.30 \text{ m}) \\ &= -(0.66 \text{ m})F_A \end{aligned}$$

counterclockwise:

$$\begin{aligned} \tau_B &= F_B r_B \\ &= F_B(0.96 \text{ m} - 0.45 \text{ m}) \\ &= (0.51 \text{ m})F_B \end{aligned}$$

- b. Write the equation for rotational equilibrium.

$$\tau_{\text{net}} = \tau_A + \tau_B = 0$$

$$\text{so } \tau_B = -\tau_A$$

$$(0.51 \text{ m})F_B = -(-0.66 \text{ m})F_A$$

$$(0.51 \text{ m})F_B = (0.66 \text{ m})F_A$$

- c. Solve the equation for F_A in terms of F_B .

$$F_g = F_A + F_B$$

$$\text{thus, } F_A = F_g - F_B$$

$$= F_g - \frac{(0.66 \text{ m})F_A}{0.51 \text{ m}}$$

$$\text{or } F_A = \frac{F_g}{1 + \frac{0.66 \text{ m}}{0.51 \text{ m}}}$$

$$= \frac{ma}{1 + \frac{0.66 \text{ m}}{0.51 \text{ m}}}$$

$$= \frac{(7.3 \text{ kg})(9.80 \text{ m/s}^2)}{1 + \frac{0.66 \text{ m}}{0.51 \text{ m}}}$$

$$= 31 \text{ N}$$

- d. How would the forces exerted by the two sawhorses change if A were moved very close to, but not directly under, the center of mass?

Chapter 8 continued

F_A would become greater, and F_B would be less.

38. A 4.5-m-long wooden plank with a 24-kg mass is supported in two places. One support is directly under the center of the board, and the other is at one end. What are the forces exerted by the two supports?

Pick the center of mass of the board as the pivot. The unsupported end exerts no torque, so the supported end does not have to exert any torque. Therefore, all the force is exerted by the center support. That force is equal to the weight of the board:

$$F_{\text{center}} = F_g = (24 \text{ kg})(9.80 \text{ m/s}^2) = 2.4 \times 10^2 \text{ N}$$

$$F_{\text{end}} = 0 \text{ N}$$

39. A 85-kg diver walks to the end of a diving board. The board, which is 3.5 m long with a mass of 14 kg, is supported at the center of mass of the board and at one end. What are the forces on the two supports?

Choose the center of mass of the board as the pivot. The force of Earth's gravity on the board is exerted totally on the support under the center of mass.

$$\tau_{\text{end}} = -\tau_{\text{diver}}$$

$$F_{\text{end}}r_{\text{end}} = -F_{\text{diver}}r_{\text{diver}}$$

$$\begin{aligned} \text{Thus, } F_{\text{end}} &= \frac{-F_{\text{diver}}r_{\text{diver}}}{r_{\text{end}}} \\ &= \frac{-m_{\text{diver}}gr_{\text{diver}}}{r_{\text{end}}} \\ &= \frac{-(85 \text{ kg})(9.80 \text{ m/s}^2)(1.75 \text{ m})}{1.75 \text{ m}} \\ &= -8.3 \times 10^2 \text{ N} \end{aligned}$$

To find the force on the center support, notice that because the board is not moving,

$$F_{\text{end}} + F_{\text{center}} = F_{\text{diver}} + F_g$$

$$\begin{aligned} \text{Thus, } F_{\text{center}} &= F_{\text{diver}} + F_g - F_{\text{end}} \\ &= 2F_{\text{diver}} + F_g \\ &= 2m_{\text{diver}}g + m_{\text{board}}g \end{aligned}$$

$$\begin{aligned} &= g(2m_{\text{diver}} + m_{\text{board}}) \\ &= (9.80 \text{ m/s}^2) \\ &\quad (2(85 \text{ kg}) + 14 \text{ kg}) \\ &= 1.8 \times 10^3 \text{ N} \end{aligned}$$

Section Review

8.3 Equilibrium pages 211–217

page 217

40. **Center of Mass** Can the center of mass of an object be located in an area where the object has no mass? Explain.

Yes, an object moves as if all its mass is concentrated at the center of mass. There is nothing in the definition that requires any or all of the object's mass to be at that location.

41. **Stability of an Object** Why is a modified vehicle with its body raised high on risers less stable than a similar vehicle with its body at normal height?

The center of mass of the vehicle will be raised, but the size of its base will not be increased. Therefore, it needs to be tipped at a smaller angle to get the center of mass outside the base of the vehicle.

42. **Conditions for Equilibrium** Give an example of an object for each of the following conditions.

a. rotational equilibrium, but not translational equilibrium

a book that is dropped so it falls without rotating

b. translational equilibrium, but not rotational equilibrium

a seesaw that is not balanced and rotates until one person's feet hit the ground

43. **Center of Mass** Where is the center of mass of a roll of masking tape?

It is in the middle of the roll, in the open space.

Chapter 8 continued

- 44. Locating the Center of Mass** Describe how you would find the center of mass of this textbook.

Obtain a piece of string and attach a small weight to it. Suspend the string and the weight from one corner of the book. Draw a line along the string. Suspend the two from another corner of the book. Again, draw a line along the string. The point where the lines cross is the center of mass.

- 45. Rotating Frames of Reference** A penny is placed on a rotating, old-fashioned record turntable. At the highest speed, the penny starts sliding outward. What are the forces acting on the penny?

Earth's mass exerts a downward force. The turntable's surface exerts both an upward force to balance gravity and an inward force due to friction that gives the penny its centripetal acceleration. There is no outward force. If it were not for friction, the penny would move in a straight line.

- 46. Critical Thinking** You have learned why the winds around a low-pressure area move in a counterclockwise direction. Would the winds move in the same or opposite direction in the southern hemisphere? Explain.
They would move in the opposite direction. Winds from the north move from the equator, where the linear speed due to rotation is highest, to mid-latitudes, where it is lower. Thus, the winds bend to the east. Winds from the south blow from regions where the linear speed is low to regions where it is higher; thus, they bend to the west. These two factors result in a clockwise rotation around a low-pressure area.

Chapter Assessment Concept Mapping

page 222

- 47.** Complete the following concept map using the following terms: *angular acceleration*, *radius*, *tangential acceleration*, *centripetal acceleration*.

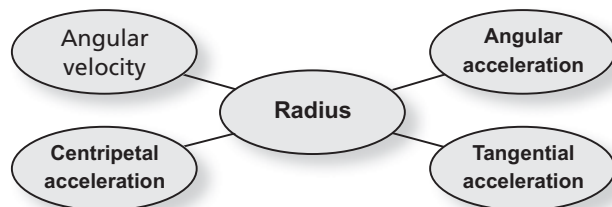

Mastering Concepts

page 222

- 48.** A bicycle wheel rotates at a constant 25 rev/min. Is its angular velocity decreasing, increasing, or constant? (8.1)
It is constant.
- 49.** A toy rotates at a constant 5 rev/min. Is its angular acceleration positive, negative, or zero? (8.1)
It is zero.
- 50.** Do all parts of Earth rotate at the same rate? Explain. (8.1)
Yes, because all parts of a rigid body rotate at the same rate.
- 51.** A unicycle wheel rotates at a constant 14 rev/min. Is the total acceleration of a point on the tire inward, outward, tangential, or zero? (8.1)
It is inward (centripetal).
- 52.** Think about some possible rotations of your textbook. Are the moments of inertia about these three axes the same or different? Explain. (8.2)
They are all different. The one with the most mass, farthest from the axis, has the greatest moment of inertia.

Chapter 8 continued

- 53.** Torque is important when tightening bolts. Why is force not important? (8.2)

An angular acceleration must be produced to tighten a bolt. Different torques can be exerted with wrenches of different lengths.

- 54.** Rank the torques on the five doors shown in **Figure 8-18** from least to greatest. Note that the magnitude of all the forces is the same. (8.2)

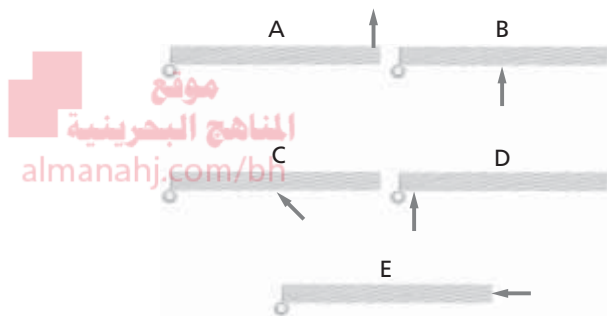

■ **Figure 8-18**

$$0 = E < D < C < B < A$$

- 55.** Explain how you can change an object's angular frequency. (8.2)
- Change the amount of torque applied to the object or change the moment of inertia.**

- 56.** To balance a car's wheel, it is placed on a vertical shaft and weights are added to make the wheel horizontal. Why is this equivalent to moving the center of mass until it is at the center of the wheel? (8.3)

When the wheel is balanced so it does not tilt (rotate) in any direction, then there is no net torque on it. This means that the center of mass is at the pivot point.

- 57.** A stunt driver maneuvers a monster truck so that it is traveling on only two wheels. Where is the center of mass of the truck? (8.3)

It is directly above the line between the points where the two wheels are touching the ground. There is no net torque on the truck, so it is momentarily stable.

- 58.** Suppose you stand flat-footed, then you rise and balance on tiptoe. If you stand with your toes touching a wall, you cannot balance on tiptoe. Explain. (8.3)

Your center of mass must be above the point of support. But your center of mass is roughly in the center of your body. Thus, while you are on your toes, about half of your body must be in front of your toes, and half must be behind. If your toes are against the wall, no part of your body can be in front of your toes.

- 59.** Why does a gymnast appear to be floating on air when she raises her arms above her head in a leap? (8.3)

She moves her center of mass closer to her head.

- 60.** Why is a vehicle with wheels that have a large diameter more likely to roll over than a vehicle with wheels that have a smaller diameter? (8.3)

The center of mass of the vehicle with the larger wheels is located at a higher point. Thus it does not have to be tilted very far before it rolls over.

Applying Concepts

pages 222–223

- 61.** Two gears are in contact and rotating. One is larger than the other, as shown in **Figure 8-19**. Compare their angular velocities. Also compare the linear velocities of two teeth that are in contact.



■ **Figure 8-19**

Chapter 8 continued

The teeth have identical linear velocities. Because the radii are different and $\omega = \frac{v}{r}$, the angular velocities are different.

62. **Videotape** When a videotape is rewound, why does it wind up fastest towards the end?

The machine turns the spool at a constant angular velocity. Towards the end, the spool has the greatest radius. Because $v = r\omega$, the velocity of the tape is fastest when the radius is greatest.

63. **Spin Cycle** What does a spin cycle of a washing machine do? Explain in terms of the forces on the clothes and water.

In the spin cycle, the water and clothes undergo great centripetal accelerations. The drum can exert forces on the clothes, but when the water reaches the holes in the drum, no inward force can be exerted on it and it therefore moves in a straight line, out of the drum.

64. How can you experimentally find the moment of inertia of an object?

You can apply a known torque and measure the resulting angular acceleration.

65. **Bicycle Wheels** Three bicycle wheels have masses that are distributed in three different ways: mostly at the rim, uniformly, and mostly at the hub. The wheels all have the same mass. If equal torques are applied to them, which one will have the greatest angular acceleration? Which one will have the least?

The more mass there is far from the axis, the greater the moment of inertia. If torque is fixed, the greater the moment of inertia, the less the angular acceleration. Thus, the wheel with mass mostly at the hub has the least moment of inertia and the greatest angular acceleration. The wheel with mass mostly near the rim has the greatest moment of inertia and the least angular acceleration.

66. **Bowling Ball** When a bowling ball leaves a bowler's hand, it does not spin. After it has gone about half the length of the lane, however, it does spin. Explain how its rotation rate increased and why it does not continue to increase.

Its rotation rate can be increased only if a torque is applied to it. The frictional force of the alley on the ball provides this force. Once the ball is rolling so that there is no velocity difference between the surface of the ball and the alley, then there is no more frictional force and thus no more torque.

67. **Flat Tire** Suppose your car has a flat tire. You get out your tools and find a lug wrench to remove the nuts off the bolt studs. You find it impossible to turn the nuts. Your friend suggests ways you might produce enough torque to turn them. What three ways might your friend suggest?

Put an extension pipe on the end of the wrench to increase the lever arm, exert your force at right angles to the wrench, or exert a greater force, perhaps by standing on the end of the wrench.

68. **Tightrope Walkers** Tightrope walkers often carry long poles that sag so that the ends are lower than the center as shown in **Figure 8-20**. How does such a pole increase the tightrope walker's stability? *Hint: Consider both center of mass and moment of inertia.*



■ Figure 8-20

Chapter 8 continued

The pole increases moment of inertia because of its mass and length. The drooping ends of the pole bring the center of mass closer to the wire, thus reducing the torque on the walker. The increased moment of inertia and decreased torque both reduce the angular acceleration if the walker becomes unbalanced. The walker can also use the pole to easily shift the center of mass over the wire to compensate for instability.

- 69. Merry-Go-Round** While riding a merry-go-round, you toss a key to a friend standing on the ground. For your friend to be able to catch the key, should you toss it a second or two before you reach the spot where your friend is standing or wait until your friend is directly behind you? Explain.

You have forward tangential velocity, so the key will leave your hand with that velocity. Therefore, you should toss it early.

- 70.** Why can you ignore forces that act on the axis of rotation of an object in static equilibrium when determining the net torque?

The torque caused by these forces is zero because the lever arm is zero.

- 71.** In solving problems about static equilibrium, why is the axis of rotation often placed at a point where one or more forces are acting on the object?

That makes the torque caused by that force equal to zero, reducing the number of torques that must be calculated.

Mastering Problems

8.1 Describing Rotational Motion

pages 223–224

Level 1

- 72.** A wheel is rotated so that a point on the edge moves through 1.50 m. The radius of the wheel is 2.50 m, as shown in **Figure 8-21**. Through what angle (in radians) is the wheel rotated?

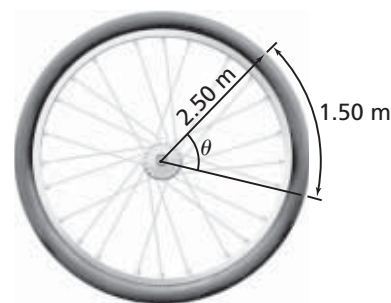

■ Figure 8-21

$$d = r\theta$$

$$\text{so } \theta = \frac{d}{r}$$

$$= \frac{1.50 \text{ m}}{2.50 \text{ m}}$$

$$= 0.600 \text{ rad}$$

- 73.** The outer edge of a truck tire that has a radius of 45 cm has a velocity of 23 m/s. What is the angular velocity of the tire in rad/s?

$$v = r\omega,$$

$$\omega = \frac{v}{r}$$

$$= \frac{23 \text{ m/s}}{0.45 \text{ m}} = 51 \text{ rad/s}$$

- 74.** A steering wheel is rotated through 128° , as shown in **Figure 8-22**. Its radius is 22 cm. How far would a point on the steering wheel's edge move?

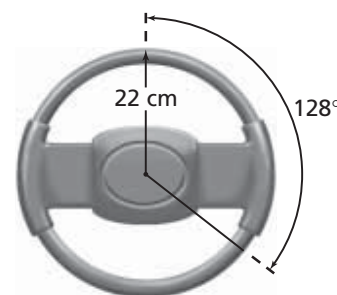

■ Figure 8-22

Chapter 8 continued

$$d = r\theta$$

$$= (0.22 \text{ m})(128^\circ)\left(\frac{2\pi \text{ rad}}{360^\circ}\right) = 0.49 \text{ m}$$

75. **Propeller** A propeller spins at 1880 rev/min.

a. What is its angular velocity in rad/s?

$$\omega = \left(1880 \frac{\text{rev}}{\text{min}}\right)\left(\frac{2\pi \text{ rad}}{\text{rev}}\right)\left(\frac{\text{min}}{60 \text{ s}}\right)$$

$$= 197 \text{ rad/s}$$

b. What is the angular displacement of the propeller in 2.50 s?

$$\theta = \omega t$$

$$= (197 \text{ rad/s})(2.50 \text{ s})$$

$$= 492 \text{ rad}$$

76. The propeller in the previous problem slows from 475 rev/min to 187 rev/min in 4.00 s. What is its angular acceleration?

$$\alpha = \frac{\Delta\omega}{\Delta t}$$

$$= \frac{\omega_f - \omega_i}{\Delta t}$$

$$= \frac{(187 \text{ rev/min} - 475 \text{ rev/min})\left(\frac{2\pi \text{ rad}}{\text{rev}}\right)}{4.00 \text{ s}}$$

$$\left(\frac{1 \text{ min}}{60 \text{ s}}\right)$$

$$= -7.54 \text{ rad/s}^2$$

77. An automobile wheel with a 9.00 cm radius, as shown in **Figure 8-23**, rotates at 2.50 rad/s. How fast does a point 7.00 cm from the center travel?



■ Figure 8-23

$$v = r\omega$$

$$= (7.00 \text{ cm})(2.50 \text{ rad/s})$$

$$= 17.5 \text{ cm/s}$$

Level 2

78. **Washing Machine** A washing machine's two spin cycles are 328 rev/min and 542 rev/min. The diameter of the drum is 0.43 m.

a. What is the ratio of the centripetal accelerations for the fast and slow spin cycles?

Recall that $a_c = \frac{v^2}{r}$ and $v = r\omega$.

$$\frac{a_{\text{fast}}}{a_{\text{slow}}} = \frac{r\omega_{\text{fast}}^2}{r\omega_{\text{slow}}^2}$$

$$= \frac{(542 \text{ rev/min})^2}{(328 \text{ rev/min})^2}$$

$$= 2.73$$

b. What is the ratio of the linear velocity of an object at the surface of the drum for the fast and slow spin cycles?

$$\frac{v_{\text{fast}}}{v_{\text{slow}}} = \frac{\omega_{\text{fast}}r}{\omega_{\text{slow}}r}$$

$$= \frac{\omega_{\text{fast}}}{\omega_{\text{slow}}}$$

$$= \frac{542 \text{ rev/min}}{328 \text{ rev/min}}$$

$$= 1.65$$

79. Find the maximum centripetal acceleration in terms of g for the washing machine in problem 78.

$$a_c = \omega^2 r \left(\frac{1 g}{9.80 \text{ m/s}^2}\right)$$

$$= \left(542 \text{ rev/min}\left(\frac{2\pi \text{ rad}}{\text{rev}}\right)\left(\frac{1 \text{ min}}{60 \text{ s}}\right)\right)^2$$

$$\left(\frac{0.43 \text{ m}}{2}\right)\left(\frac{1 g}{9.80 \text{ m/s}^2}\right)$$

$$= 71g$$

Level 3

80. A laboratory ultracentrifuge is designed to produce a centripetal acceleration of $0.35 \times 10^6 g$ at a distance of 2.50 cm from the axis. What angular velocity in rev/min is required?

Chapter 8 continued

$$a_c = \omega^2 r$$

$$\text{so } \omega = \sqrt{\frac{a_c}{r}}$$

$$= \sqrt{\frac{(0.35 \times 10^6)(9.80 \text{ m/s}^2)}{0.025 \text{ m}}} \left(\frac{\text{rev}}{2\pi \text{ rad}} \right)$$

$$\left(\frac{60 \text{ s}}{1 \text{ min}} \right)$$

$$= 1.1 \times 10^5 \text{ rev/min}$$

8.2 Rotational Dynamics

page 224

Level 1

81. **Wrench** A bolt is to be tightened with a torque of 8.0 N·m. If you have a wrench that is 0.35 m long, what is the least amount of force you must exert?

$$\tau = Fr \sin \theta$$

$$\text{so } F = \frac{\tau}{r \sin \theta}$$

For the least possible force, the angle is 90.0°, then

$$F = \frac{8.0 \text{ N}\cdot\text{m}}{(0.35 \text{ m})(\sin 90.0^\circ)}$$

$$= 23 \text{ N}$$

82. What is the torque on a bolt produced by a 15-N force exerted perpendicular to a wrench that is 25 cm long, as shown in Figure 8-24?

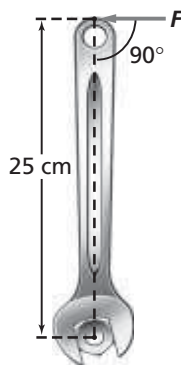

■ Figure 8-24

$$\tau = Fr \sin \theta$$

$$= (15 \text{ N})(0.25 \text{ m})(\sin 90.0^\circ)$$

$$= 3.8 \text{ N}\cdot\text{m}$$

83. A toy consisting of two balls, each 0.45 kg, at the ends of a 0.46-m-long, thin, light-weight rod is shown in Figure 8-25. Find the moment of inertia of the toy. The moment of inertia is to be found about the center of the rod.

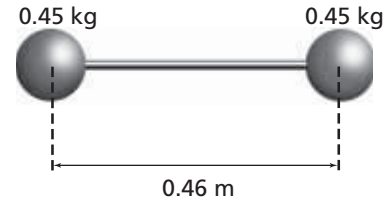

■ Figure 8-25

$$I = mr^2$$

$$= (0.45 \text{ kg})(0.23 \text{ m})^2 + (0.45 \text{ kg})(0.23 \text{ m})^2$$

$$= 0.048 \text{ kg}\cdot\text{m}^2$$

Level 2

84. A bicycle wheel with a radius of 38 cm is given an angular acceleration of 2.67 rad/s² by applying a force of 0.35 N on the edge of the wheel. What is the wheel's moment of inertia?

$$\alpha = \frac{\tau}{I}$$

$$I = \frac{\tau}{\alpha}$$

$$= \frac{Fr \sin \theta}{\alpha}$$

$$= \frac{(0.35 \text{ N})(0.38 \text{ m})(\sin 90.0^\circ)}{2.67 \text{ rad/s}^2}$$

$$= 0.050 \text{ kg}\cdot\text{m}^2$$

Level 3

85. **Toy Top** A toy top consists of a rod with a diameter of 8.0-mm and a disk of mass 0.0125 kg and a diameter of 3.5 cm. The moment of inertia of the rod can be neglected. The top is spun by wrapping a string around the rod and pulling it with a velocity that increases from zero to 3.0 m/s over 0.50 s.

Chapter 8 continued

- a. What is the resulting angular velocity of the top?

$$\begin{aligned}\omega_f &= \frac{v_f}{r_{\text{rod}}} \\ &= \frac{3.0 \text{ m/s}}{\left(\frac{1}{2}\right)(0.0080 \text{ m})} \\ &= 7.5 \times 10^2 \text{ rad/s}\end{aligned}$$

- b. What force was exerted on the string?

$$\tau = Fr_{\text{rod}} \sin \theta \text{ and } \tau = \alpha l$$

$$\text{Thus, } Fr_{\text{rod}} \sin \theta = \alpha l$$

$$F = \frac{\alpha l}{r_{\text{rod}} \sin \theta}$$

$$= \frac{\left(\frac{\Delta\omega}{\Delta t}\right)\left(\frac{1}{2}\right)mr_{\text{disk}}^2}{r_{\text{rod}} \sin \theta}$$

$$= \frac{\Delta\omega mr_{\text{disk}}^2}{2\Delta t r_{\text{rod}} \sin \theta}$$

$$= \frac{(\omega_f - \omega_i)mr_{\text{disk}}^2}{2\Delta t r_{\text{rod}} \sin \theta}$$

$$= \frac{(7.5 \times 10^2 \text{ rad/s} - 0.0 \text{ rad/s})(0.0125 \text{ kg})\left(\frac{0.035 \text{ m}}{2}\right)^2}{(2)(0.50 \text{ s})\left(\frac{0.0080 \text{ m}}{2}\right)(\sin 90.0^\circ)}$$

$$= 0.72 \text{ N}$$

8.3 Equilibrium

page 224

Level 1

86. A 12.5-kg board, 4.00 m long, is being held up on one end by Ahmed. He calls for help, and Judi responds.

- a. What is the least force that Judi could exert to lift the board to the horizontal position? What part of the board should she lift to exert this force?

At the opposite end, she will only lift half the mass.

$$\begin{aligned}F_{\text{least}} &= mg \\ &= \left(\frac{1}{2}\right)(12.5 \text{ kg})(9.80 \text{ m/s}^2) \\ &= 61.2 \text{ N}\end{aligned}$$

- b. What is the greatest force that Judi could exert to lift the board to the horizontal position? What part of the board should she lift to exert this force?

At the board's center of mass (middle), she will lift the entire mass.

$$\begin{aligned}F_{\text{greatest}} &= mg \\ &= (12.5 \text{ kg})(9.80 \text{ m/s}^2) \\ &= 122 \text{ N}\end{aligned}$$

Chapter 8 continued

Level 2

- 87.** Two people are holding up the ends of a 4.25-kg wooden board that is 1.75 m long. A 6.00-kg box sits on the board, 0.50 m from one end, as shown in **Figure 8-26**. What forces do the two people exert?

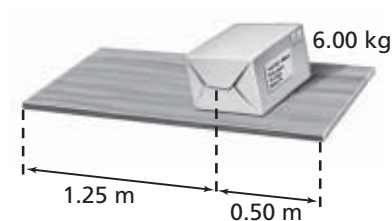

■ Figure 8-26

$$F_{\text{left}} + F_{\text{right}} + F_{\text{board}} + F_{\text{box}} = 0$$

$$\tau_{\text{left}} + \tau_{\text{right}} + \tau_{\text{board}} + \tau_{\text{box}} = 0$$

We can choose the axis of rotation at the location of one of the unknown forces (F_{left}) so that torque is eliminated, thus simplifying the calculations.

$$F_{\text{left}}r_{\text{left}} + F_{\text{right}}r_{\text{right}} + F_{\text{board}}r_{\text{board}} + F_{\text{box}}r_{\text{box}} = 0$$

$$F_{\text{left}}r_{\text{left}} + F_{\text{right}}r_{\text{right}} + m_{\text{board}}gr_{\text{board}} + m_{\text{box}}gr_{\text{box}} = 0$$

$$F_{\text{left}}(0) + F_{\text{right}}(1.25 \text{ m} + 0.50 \text{ m}) + (4.25 \text{ kg})(-9.80 \text{ m/s}^2)\left(\frac{1.25 \text{ m} + 0.50 \text{ m}}{2}\right) + (6.00 \text{ kg})(-9.80 \text{ m/s}^2)(1.25 \text{ m}) = 0$$

$$F_{\text{right}} = 63 \text{ N}$$

Substituting this into the force equation,

$$F_{\text{left}} + F_{\text{right}} + F_{\text{board}} + F_{\text{box}} = 0$$

$$F_{\text{left}} = -F_{\text{right}} - F_{\text{board}} - F_{\text{box}}$$

$$= -F_{\text{right}} - m_{\text{board}}g - m_{\text{box}}g$$

$$= -(63 \text{ N}) - (4.25 \text{ kg})(-9.80 \text{ m/s}^2)$$

$$- (6.00 \text{ kg})(-9.80 \text{ m/s}^2)$$

$$= 37 \text{ N}$$

Level 3

- 88.** A car's specifications state that its weight distribution is 53 percent on the front tires and 47 percent on the rear tires. The wheel base is 2.46 m. Where is the car's center of mass?

Let the center of mass be x from the front of the car. Let the weight of the car be F_g .

$$\tau_{\text{front}} = \tau_{\text{rear}}$$

$$F_{\text{front}}r_{\text{front}} = F_{\text{rear}}r_{\text{rear}}$$

$$(0.53 F_g)x = (0.47 F_g)(2.46 \text{ m} - x)$$

$$x = 1.16 \text{ m}$$

Mixed Review

pages 224–225

Level 1

- 89.** A wooden door of mass, m , and length, l , is held horizontally by Dan and Ajit. Dan suddenly drops his end.

Chapter 8 continued

- a. What is the angular acceleration of the door just after Dan lets go?

The torque is due to the gravitational force. The force at the center of mass is mg .

$$\begin{aligned} \text{Thus, } \alpha &= \frac{\tau}{I} \\ &= \frac{Fr \sin \theta}{\left(\frac{1}{3}\right)ml^2} \\ &= \frac{mg\left(\frac{1}{2}l\right)(\sin 90.0^\circ)}{\left(\frac{1}{3}\right)ml^2} \\ &= \frac{3}{2}gl \end{aligned}$$

- b. Is the acceleration constant? Explain.

No; the angle between the door and the weight is changing, and therefore the torque is also changing. Thus, the acceleration changes.

90. **Topsoil** Ten bags of topsoil, each weighing 175 N, are placed on a 2.43-m-long sheet of wood. They are stacked 0.50 m from one end of the sheet of wood, as shown in Figure 8-27. Two people lift the sheet of wood, one at each end. Ignoring the weight of the wood, how much force must each person exert?

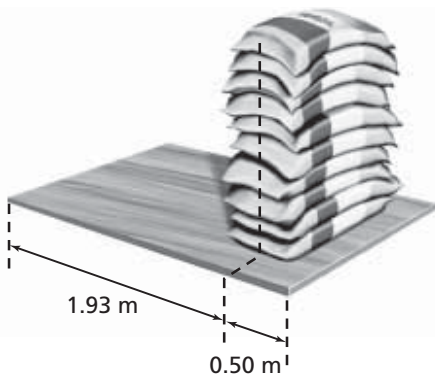

Figure 8-27

In equilibrium, the sum of the forces is zero and the sum of the torques is zero.

$$F_{\text{left}} + F_{\text{right}} + F_{\text{bags}} = 0$$

$$\tau_{\text{left}} + \tau_{\text{right}} + \tau_{\text{bags}} = 0$$

Choose the location of F_{right} as the axis of rotation to make that torque zero.

Then,

$$\tau_{\text{left}} = -\tau_{\text{bags}}$$

$$F_{\text{left}}r_{\text{left}} = -F_{\text{bags}}r_{\text{bags}}$$

$$\begin{aligned} F_{\text{left}} &= \frac{-F_{\text{bags}}r_{\text{bags}}}{r_{\text{left}}} \\ &= \frac{-(10)(-175 \text{ N})(0.50 \text{ m})}{2.43 \text{ m}} \\ &= 3.6 \times 10^2 \text{ N} \end{aligned}$$

Substitute this into the force equation.

$$F_{\text{left}} + F_{\text{right}} + F_{\text{bags}} = 0$$

$$\begin{aligned} F_{\text{right}} &= -F_{\text{left}} - F_{\text{bags}} \\ &= -3.6 \times 10^2 \text{ N} - 10(-175 \text{ N}) \\ &= 1.4 \times 10^2 \text{ N} \end{aligned}$$

91. **Basketball** A basketball is rolled down the court. A regulation basketball has a diameter of 24.1 cm, a mass of 0.60 kg, and a moment of inertia of $5.8 \times 10^{-3} \text{ kg}\cdot\text{m}^2$. The basketball's initial velocity is 2.5 m/s.

- a. What is its initial angular velocity?

$$\begin{aligned} \omega &= \frac{v}{r} \\ &= \frac{2.5 \text{ m/s}}{\frac{1}{2}(0.241 \text{ m})} \\ &= 21 \text{ rad/s} \end{aligned}$$

- b. The ball rolls a total of 12 m. How many revolutions does it make?

$$\begin{aligned} d &= r\theta \\ \text{so } \theta &= \frac{d}{r} \\ &= \frac{12 \text{ m}}{\left(\frac{1}{2}\right)(0.241 \text{ m})} \left(\frac{\text{rev}}{2\pi \text{ rad}}\right) \\ &= 16 \text{ rev} \end{aligned}$$

- c. What is its total angular displacement?

$$\begin{aligned} d &= r\theta \\ \text{so } \theta &= \frac{d}{r} \\ &= \frac{12 \text{ m}}{\left(\frac{1}{2}\right)(0.241 \text{ m})} \\ &= 1.0 \times 10^2 \text{ rad} \end{aligned}$$

Chapter 8 continued

92. The basketball in the previous problem stops rolling after traveling 12 m.

- a. If its acceleration was constant, what was its angular acceleration?

$$v_f^2 = v_i^2 + 2ad$$

$$\text{so } a = \frac{-v_i^2}{2d}$$

$$\begin{aligned} \text{Thus, } \alpha &= \frac{a}{r} = \frac{-v_i^2}{2rd} \\ &= \frac{-(2.5 \text{ m/s})^2}{2\left(\frac{1}{2}\right)(0.241 \text{ m})(12 \text{ m})} \\ &= -2.2 \text{ rad/s}^2 \end{aligned}$$

- b. What torque was acting on it as it was slowing down?

$$\begin{aligned} \tau &= I\alpha \\ &= (5.8 \times 10^{-3} \text{ kg}\cdot\text{m}^2)(-2.2 \text{ rad/s}^2) \\ &= -1.3 \times 10^{-2} \text{ N}\cdot\text{m} \end{aligned}$$

93. A cylinder with a 50 m diameter, as shown in **Figure 8-28**, is at rest on a surface. A rope is wrapped around the cylinder and pulled. The cylinder rolls without slipping.

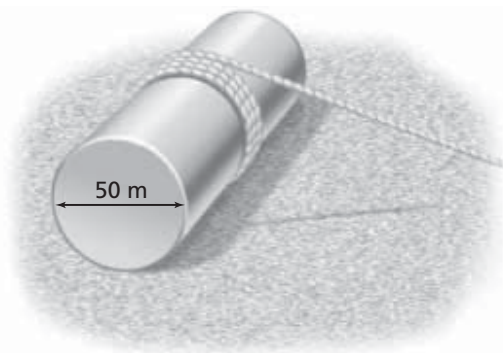

■ **Figure 8-28**

- a. After the rope has been pulled a distance of 2.50 m at a constant speed, how far has the center of mass of the cylinder moved?

The center of mass is always over the point of contact with the surface for a uniform cylinder. Therefore the center of mass has moved 2.50 m.

- b. If the rope was pulled a distance of 2.50 m in 1.25 s, how fast was the center of mass of the cylinder moving?

$$\begin{aligned} v &= \frac{d}{t} \\ &= \frac{(2.50 \text{ m})}{(1.25 \text{ s})} \\ &= 2.00 \text{ m/s} \end{aligned}$$

- c. What is the angular velocity of the cylinder?

$$\begin{aligned} \omega &= \frac{v}{r} \\ &= \frac{2.00 \text{ m/s}}{\left(\frac{1}{2}\right)(50 \text{ m})} \\ &= 8 \times 10^{-2} \text{ rad/s} \end{aligned}$$

94. Hard Drive A hard drive on a modern computer spins at 7200 rpm (revolutions per minute). If the drive is designed to start from rest and reach operating speed in 1.5 s, what is the angular acceleration of the disk?

$$\begin{aligned} \alpha &= \frac{\Delta\omega}{\Delta t} = \frac{\omega_f - \omega_i}{\Delta t} \\ &= \frac{(7200 \text{ rpm} - 0 \text{ rpm})}{1.5 \text{ s}} \left(\frac{2\pi \text{ rad}}{\text{rev}} \right) \left(\frac{1 \text{ min}}{60 \text{ s}} \right) \\ &= 5.0 \times 10^2 \text{ rad/s}^2 \end{aligned}$$

95. Speedometers Most speedometers in automobiles measure the angular velocity of the transmission and convert it to speed. How will increasing the diameter of the tires affect the reading of the speedometer?

Because increasing the diameter decreases the angular velocity, it will also decrease the reading of the speedometer.

96. A box is dragged across the floor using a rope that is a distance h above the floor. The coefficient of friction is 0.35. The box is 0.50 m high and 0.25 m wide. Find the force that just tips the box.

Let M equal the mass of the box. The center of mass of the box is 0.25 m above the floor. The box just tips when the torques on it are equal.

$$\tau_{\text{rope}} = \tau_{\text{friction}}$$

$$F_{\text{rope}}r_{\text{rope}} = F_{\text{friction}}r_{\text{friction}}$$

Chapter 8 continued

$$\begin{aligned}
 F_{\text{rope}} &= \frac{F_{\text{friction}} r_{\text{friction}}}{r_{\text{rope}}} \\
 &= \frac{\mu M g r_{\text{friction}}}{r_{\text{rope}}} \\
 &= \frac{(0.35)M(9.80 \text{ m/s}^2)(0.25 \text{ m})}{h - 0.25 \text{ m}} \\
 &= \frac{(0.86 \text{ m}^2/\text{s}^2)M}{h - 0.25 \text{ m}}
 \end{aligned}$$

Note that when you pull the box at the height of its center of mass, the denominator becomes zero. That is, you can pull with any amount of force and not tip the box.

97. The second hand on a watch is 12 mm long. What is the velocity of its tip?

$$\begin{aligned}
 v &= r\omega \\
 &= (0.012 \text{ m})(-2\pi \text{ rad/min})\left(\frac{\text{min}}{60 \text{ s}}\right) \\
 &= -1.3 \times 10^{-3} \text{ m/s}
 \end{aligned}$$

Level 2

98. **Lumber** You buy a 2.44-m-long piece of 10 cm × 10 cm lumber. Your friend buys a piece of the same size and cuts it into two lengths, each 1.22 m long, as shown in Figure 8-29. You each carry your lumber on your shoulders.

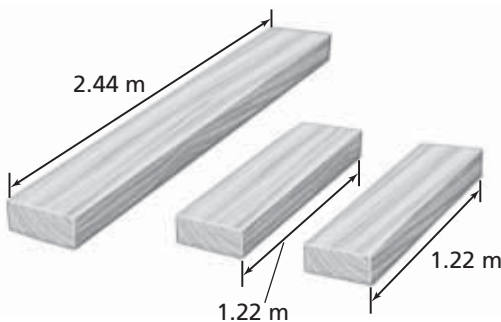

Figure 8-29

- a. Which load is easier to lift? Why?
The masses are the same, so the weights are the same. Thus, the same upward force is required to lift each load.
- b. Both you and your friend apply a torque with your hands to keep the lumber from rotating. Which load is easier to keep from rotating? Why?

The longer piece of lumber would be easier to keep from rotating because it has a greater moment of inertia.

99. **Surfboard** Harris and Paul carry a surfboard that is 2.43 m long and weighs 143 N. Paul lifts one end with a force of 57 N.

- a. What force must Harris exert?

$$\begin{aligned}
 F_H &= F_g - F_P \\
 &= 143 \text{ N} - 57 \text{ N} \\
 &= 86 \text{ N}
 \end{aligned}$$

- b. What part of the board should Harris lift?

Choose the point of rotation at the end where Paul lifts.

$$\begin{aligned}
 \tau_H &= \tau_g \\
 F_H r_H &= F_g r_g \\
 r_H &= \frac{F_g r_g}{F_H} \\
 &= \frac{(143 \text{ N})\left(\frac{2.43 \text{ m}}{2}\right)}{86 \text{ N}} \\
 &= 2.0 \text{ m}
 \end{aligned}$$

Thus, Harris has to lift 2.0 m from Paul's end of the board.

100. A steel beam that is 6.50 m long weighs 325 N. It rests on two supports, 3.00 m apart, with equal amounts of the beam extending from each end. Suki, who weighs 575 N, stands on the beam in the center and then walks toward one end. How close to the end can she come before the beam begins to tip?

Each support is 1.75 m from the end of the beam. Choose the point of rotation to be the support at the end closer to Suki. The center of mass of the beam is 1.50 m from that support. The beam will just begin to tip when Suki's torque (τ_S) equals the torque of the beam's center of mass (τ_{cm}) and the entire weight is on the support closest to Suki.

$$\begin{aligned}
 \tau_S &= \tau_{\text{cm}} \\
 F_S r_S &= F_{\text{cm}} r_{\text{cm}}
 \end{aligned}$$

Chapter 8 continued

$$r_S = \frac{F_{cm} r_{cm}}{F_S}$$

$$= \frac{(325 \text{ N})\left(\frac{3.00 \text{ m}}{2}\right)}{575 \text{ N}}$$

$$= 0.848 \text{ m}$$

That is Suki can move **0.848 m** from the support or $1.75 - 0.848 = 0.90 \text{ m}$ from the end.

Thinking Critically

pages 225–226

101. Apply Concepts Consider a point on the edge of a rotating wheel.

a. Under what conditions can the centripetal acceleration be zero?

when $\omega = 0.0$

b. Under what conditions can the tangential (linear) acceleration be zero?

when $\alpha = 0.0$

c. Can the tangential acceleration be nonzero while the centripetal acceleration is zero? Explain.

When $\omega = 0.0$ instantaneously, but α is not zero, ω will keep changing.

d. Can the centripetal acceleration be nonzero while the tangential acceleration is zero? Explain.

Yes, as long as ω is constant but not zero.

102. Apply Concepts When you apply the brakes in a car, the front end dips. Why?

The road exerts a force on the tires that brings the car to rest. The center of mass is above the road. Therefore, there is a net torque on the car, causing it to rotate in the direction that forces the front down.

103. Analyze and Conclude A banner is suspended from a horizontal, pivoted pole, as shown in **Figure 8-30**. The pole is 2.10 m long and weighs 175 N. The banner, which weighs 105 N, is suspended 1.80 m from the pivot point or axis of rotation. What is the tension in the cable supporting the pole?

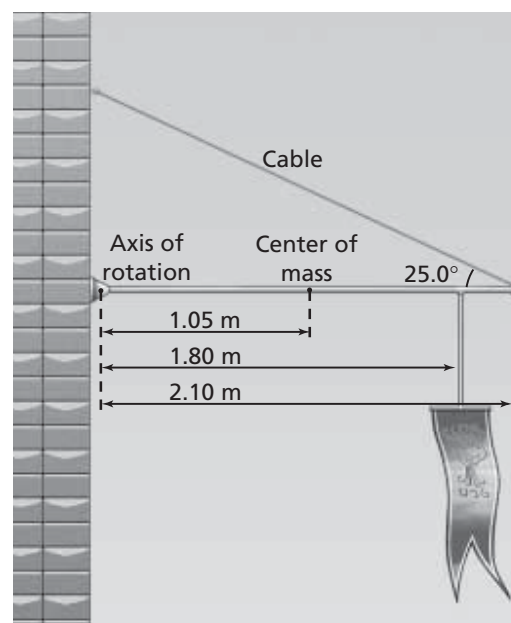

■ Figure 8-30

We can use torques to find the vertical component (F_{Ty}) of the tension. The counterclockwise torques are in equilibrium with the clockwise torques.

$$\tau_{ccw} = \tau_{cw}$$

$$\tau_{cable} = \tau_{pole} + \tau_{banner}$$

$$F_{Ty} r_{cable} = F_{pole} r_{pole} + F_{banner} r_{banner}$$

$$F_{Ty} = \frac{F_{pole} r_{pole} + F_{banner} r_{banner}}{r_{cable}}$$

The total tension, then, is

$$F_T = \frac{F_{Ty}}{\sin 25^\circ} = \frac{F_{pole} r_{pole} + F_{banner} r_{banner}}{r_{cable} \sin 25^\circ}$$

$$= \frac{(175 \text{ N})(1.05 \text{ m}) + (105 \text{ N})(1.80 \text{ m})}{(2.10 \text{ m}) \sin 25^\circ}$$

$$= 420 \text{ N}$$

Chapter 8 continued

104. Analyze and Conclude A pivoted lamp pole is shown in **Figure 8-31**. The pole weighs 27 N, and the lamp weighs 64 N.

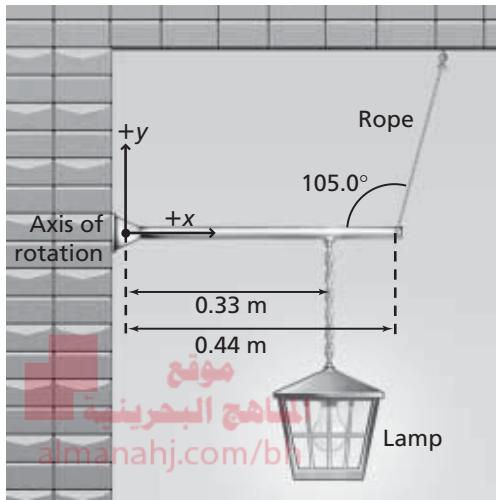

■ **Figure 8-31**

a. What is the torque caused by each force?

$$\begin{aligned} \tau_g &= F_g r \sin \theta \\ &= (27 \text{ N})(0.22 \text{ m})(\sin 90.0^\circ) \\ &= 5.9 \text{ N}\cdot\text{m} \end{aligned}$$

$$\begin{aligned} \tau_{\text{lamp}} &= F_{\text{lamp}} r \sin \theta \\ &= (64 \text{ N})(0.33 \text{ m})(\sin 90.0^\circ) \\ &= 21 \text{ N}\cdot\text{m} \end{aligned}$$

b. Determine the tension in the rope supporting the lamp pole.

Use the torques to find the vertical component (F_{Ty}) of the tension. The counterclockwise torques are in equilibrium with the clockwise torques.

$$\tau_{\text{ccw}} = \tau_{\text{cw}}$$

$$\tau_{\text{rope}} = \tau_{\text{pole}} + \tau_{\text{lamp}}$$

$$F_{Ty} r_{\text{rope}} = F_{\text{pole}} r_{\text{pole}} + F_{\text{lamp}} r_{\text{lamp}}$$

$$F_{Ty} = \frac{F_{\text{pole}} r_{\text{pole}} + F_{\text{lamp}} r_{\text{lamp}}}{r_{\text{rope}}}$$

The total tension, then, is

$$\begin{aligned} F_T &= \frac{F_{Ty}}{\sin 105^\circ} \\ &= \frac{F_{\text{pole}} r_{\text{pole}} + F_{\text{lamp}} r_{\text{lamp}}}{r_{\text{rope}} \sin 105^\circ} \\ &= \frac{(27 \text{ N})\left(\frac{0.44 \text{ m}}{2}\right) + (64 \text{ N})(0.33 \text{ m})}{(0.44 \text{ m})(\sin 105^\circ)} \\ &= 64 \text{ N} \end{aligned}$$

105. Analyze and Conclude Gerald and Evelyn carry the following objects up a flight of stairs: a large mirror, a dresser, and a television. Evelyn is at the front end, and Gerald is at the bottom end. Assume that both Evelyn and Gerald exert only upward forces.

a. Draw a free-body diagram showing Gerald and Evelyn exerting the same force on the mirror.

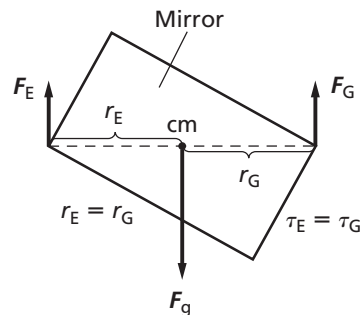

b. Draw a free-body diagram showing Gerald exerting more force on the bottom of the dresser.

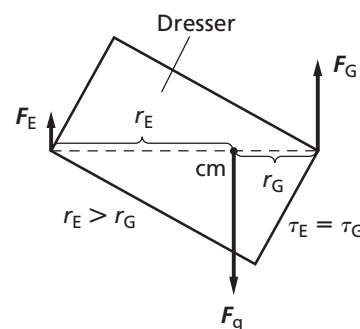

Chapter 8 continued

- c. Where would the center of mass of the television have to be so that Gerald carries all the weight?

directly above where Gerald is lifting

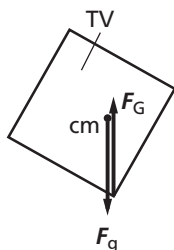

Writing in Physics

page 226

106. Astronomers know that if a satellite is too close to a planet, it will be torn apart by tidal forces. That is, the difference in the gravitational force on the part of the satellite nearest the planet and the part farthest from the planet is stronger than the forces holding the satellite together. Do research on the Roche limit and determine how close the Moon would have to orbit Earth to be at the Roche limit.

For a planet and a moon with identical densities, the Roche limit is 2.446 times the radius of the planet. Earth's Roche limit is 18,470 km.

107. Automobile engines are rated by the torque that they produce. Research and explain why torque is an important quantity to measure.

The force exerted by the ground on the tire accelerates the car. This force is produced by the engine. It creates the force by rotating the axle. The torque is equal to the force on the edge of the tire multiplied by the radius of the tire. Gears in the transmission may cause the force to change, but they do not change the torque. Therefore, the amount of torque created by the engine is delivered to the wheels.

Cumulative Review

page 226

108. Two blocks, one of mass 2.0 kg and the other of mass 3.0 kg, are tied together with a massless rope. This rope is strung over a massless, resistance-free pulley. The blocks are released from rest. Find the following. (Chapter 4)

- a. the tension in the rope

The tension on the rope is

$$T - m_2g = m_2a$$

$$T - m_3g = m_3a$$

Thus,

$$a = \left(\frac{m_3 - m_2}{m_3 + m_2} \right) g$$

Substitute into the first equation.

$$\begin{aligned} T &= \left(\frac{2m_2m_3}{m_2 + m_3} \right) g \\ &= \frac{2(2 \text{ kg})(3 \text{ kg})}{2 \text{ kg} + 3 \text{ kg}} (9.80 \text{ m/s}^2) \\ &= 24 \text{ N} \end{aligned}$$

- b. the acceleration of the blocks.

Substitute into the equation for a.

$$\begin{aligned} a &= \left(\frac{m_3 - m_2}{m_3 + m_2} \right) g \\ &= \left(\frac{3 \text{ kg} - 2 \text{ kg}}{3 \text{ kg} + 2 \text{ kg}} \right) (9.80 \text{ m/s}^2) \\ &= 1.96 \text{ m/s}^2 \end{aligned}$$

109. Eric sits on a see-saw. At what angle, relative to the vertical, will the component of his weight parallel to the plane be equal to one-third the perpendicular component of his weight? (Chapter 5)

$$F_{g, \text{ parallel}} = F_g \sin \theta$$

$$F_{g, \text{ perpendicular}} = F_g \cos \theta$$

$$F_{g, \text{ perpendicular}} = 3F_{g, \text{ parallel}}$$

$$3 = \frac{F_{g, \text{ perpendicular}}}{F_{g, \text{ parallel}}}$$

$$3 = \frac{F_g \cos \theta}{F_g \sin \theta} = \frac{1}{\tan \theta}$$

$$\theta = \tan^{-1}(3) = 71.6^\circ$$

Chapter 8 continued

- 110.** The pilot of a plane wants to reach an airport 325 km due north in 2.75 hours. A wind is blowing from the west at 30.0 km/h. What heading and airspeed should be chosen to reach the destination on time? (Chapter 6)

Let g be the distance north to the airport, x be the westward deflection, and h be the actual distance traveled. First, find the heading as the angle θ traveled eastward from the northward path.

$$\tan \theta = \frac{v_x}{v_y}$$

$$\theta = \tan^{-1}\left(\frac{v_x}{v_y}\right)$$

$$= \tan^{-1}\left(\frac{v_x t_y}{d_y}\right)$$

$$= \tan^{-1}\left(\frac{(30.0 \text{ km/h})(2.75 \text{ h})}{325 \text{ km}}\right)$$

$$= 14.3^\circ \text{ west of north}$$

The airspeed, then, should be

$$v_h^2 = v_x^2 + v_y^2$$

$$v_h = (v_x^2 + v_y^2)^{\frac{1}{2}}$$

$$= \left(v_x^2 + \frac{d_y^2}{t_y^2}\right)^{\frac{1}{2}}$$

$$= \left((30.0 \text{ km/h})^2 + \frac{(325 \text{ km})^2}{(2.75 \text{ h})^2}\right)^{\frac{1}{2}}$$

$$= 122 \text{ km/h}$$

- 111.** A 60.0-kg speed skater with a velocity of 18.0 m/s comes into a curve of 20.0-m radius. How much friction must be exerted between the skates and ice to negotiate the curve? (Chapter 6)

$$F_f = F_{\text{net}} = \frac{mv^2}{r}$$

$$= \frac{(60.0 \text{ kg})(18.0 \text{ m/s})^2}{20.0 \text{ m}} = 972 \text{ N}$$

Challenge Problem

page 208

Rank the objects shown in the diagram according to their moments of inertia about the indicated axes. All spheres have equal masses and all separations are the same.

$b > c > d > a$

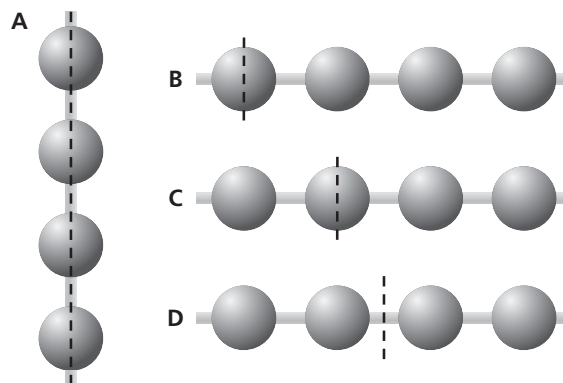

CHAPTER
9

Momentum and Its Conservation

Practice Problems

9.1 Impulse and Momentum pages 229–235

page 233

1. A compact car, with mass 725 kg, is moving at 115 km/h toward the east. Sketch the moving car.
 - a. Find the magnitude and direction of its momentum. Draw an arrow on your sketch showing the momentum.

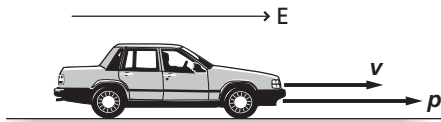

$$\begin{aligned}
 p &= mv \\
 &= (725 \text{ kg})(115 \text{ km/h}) \\
 &\quad \left(\frac{1000 \text{ m}}{1 \text{ km}} \right) \left(\frac{1 \text{ h}}{3600 \text{ s}} \right) \\
 &= 2.32 \times 10^4 \text{ kg}\cdot\text{m/s eastward}
 \end{aligned}$$

- b. A second car, with a mass of 2175 kg, has the same momentum. What is its velocity?

$$\begin{aligned}
 v &= \frac{p}{m} \\
 &= \frac{(2.32 \times 10^4 \text{ kg}\cdot\text{m/s}) \left(\frac{3600 \text{ s}}{1 \text{ h}} \right) \left(\frac{1 \text{ km}}{1000 \text{ m}} \right)}{2175 \text{ kg}} \\
 &= 38.4 \text{ km/h eastward}
 \end{aligned}$$

2. The driver of the compact car in the previous problem suddenly applies the brakes hard for 2.0 s. As a result, an average force of $5.0 \times 10^3 \text{ N}$ is exerted on the car to slow it down.

$$\Delta t = 2.0 \text{ s}$$

$$F = -5.0 \times 10^3 \text{ N}$$

- a. What is the change in momentum; that is, the magnitude and direction of the impulse, on the car?

$$\begin{aligned}
 \text{impulse} &= F\Delta t \\
 &= (-5.0 \times 10^3 \text{ N})(2.0 \text{ s}) \\
 &= -1.0 \times 10^4 \text{ N}\cdot\text{s}
 \end{aligned}$$

The impulse is directed westward and has a magnitude of $1.0 \times 10^4 \text{ N}\cdot\text{s}$.

- b. Complete the “before” and “after” sketches, and determine the momentum and the velocity of the car now.

Before

After

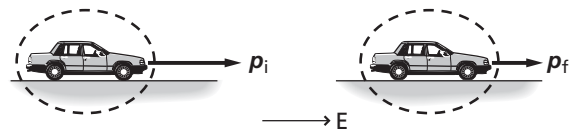

$$p_i = 2.32 \times 10^4 \text{ kg}\cdot\text{m/s eastward}$$

$$F\Delta t = \Delta p = p_f - p_i$$

$$\begin{aligned}
 p_f &= F\Delta t + p_i \\
 &= -1.0 \times 10^4 \text{ kg}\cdot\text{m/s} + \\
 &\quad 2.32 \times 10^4 \text{ kg}\cdot\text{m/s}
 \end{aligned}$$

$$= 1.3 \times 10^4 \text{ kg}\cdot\text{m/s eastward}$$

$$p_f = mv_f$$

$$v_f = \frac{p_f}{m} = \frac{1.3 \times 10^4 \text{ kg}\cdot\text{m/s}}{725 \text{ kg}}$$

$$= 18 \text{ m/s}$$

$$= 65 \text{ km/h eastward}$$

3. A 7.0-kg bowling ball is rolling down the alley with a velocity of 2.0 m/s. For each impulse, shown in **Figures 9-3a** and **9-3b**, find the resulting speed and direction of motion of the bowling ball.

a.

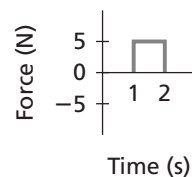

b.

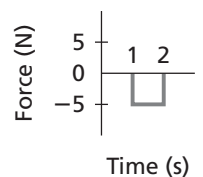

■ Figure 9-3

Chapter 9 continued

a. $F\Delta t = p_f - p_i = mv_f - mv_i$

$$v_f = \frac{F\Delta t - mv_i}{m}$$

$$= \frac{(5.0 \text{ N})(1.0 \text{ s}) + (7.0 \text{ kg})(2.0 \text{ m/s})}{7.0 \text{ kg}}$$

= 2.7 m/s in the same direction as the original velocity

b. $v_f = \frac{F\Delta t - mv_i}{m}$

$$= \frac{(-5.0 \text{ N})(1.0 \text{ s}) + (7.0 \text{ kg})(2.0 \text{ m/s})}{7.0 \text{ kg}}$$

= 1.3 m/s in the same direction as the original velocity

4. The driver accelerates a 240.0-kg snowmobile, which results in a force being exerted that speeds up the snowmobile from 6.00 m/s to 28.0 m/s over a time interval of 60.0 s.

- a. Sketch the event, showing the initial and final situations.

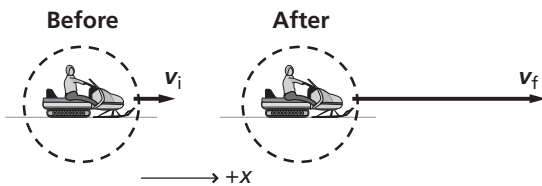

- b. What is the snowmobile's change in momentum? What is the impulse on the snowmobile?
- $$\Delta p = F\Delta t$$
- $$= m(v_f - v_i)$$
- $$= (240.0 \text{ kg})(28.0 \text{ m/s} - 6.00 \text{ m/s})$$
- $$= 5.28 \times 10^3 \text{ kg}\cdot\text{m/s}$$
- c. What is the magnitude of the average force that is exerted on the snowmobile?

$$F = \frac{\Delta p}{\Delta t} = \frac{5.28 \times 10^3 \text{ kg}\cdot\text{m/s}}{60.0 \text{ s}}$$

$$= 88.0 \text{ N}$$

5. Suppose a 60.0-kg person was in the vehicle that hit the concrete wall in Example Problem 1. The velocity of the person equals that of the car both before and after the crash, and the velocity changes in 0.20 s. Sketch the problem.

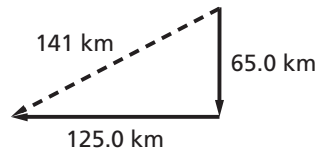

- a. What is the average force exerted on the person?

$$F\Delta t = \Delta p = p_f - p_i$$

$$F = \frac{p_f - p_i}{\Delta t}$$

$$F = \frac{p_f - mv_i}{\Delta t}$$

$$= \frac{(0.0 \text{ kg}\cdot\text{m/s}) - (60.0 \text{ kg})(94 \text{ km/h})}{0.20 \text{ s}}$$

$$\left(\frac{1000 \text{ m}}{1 \text{ km}}\right)\left(\frac{1 \text{ h}}{3600 \text{ s}}\right)$$

$$= 7.8 \times 10^3 \text{ N opposite to the direction of motion}$$

- b. Some people think that they can stop their bodies from lurching forward in a vehicle that is suddenly braking by putting their hands on the dashboard. Find the mass of an object that has a weight equal to the force you just calculated. Could you lift such a mass? Are you strong enough to stop your body with your arms?

$$F_g = mg$$

$$m = \frac{F_g}{g} = \frac{7.8 \times 10^3 \text{ N}}{9.80 \text{ m/s}^2} = 8.0 \times 10^2 \text{ kg}$$

Such a mass is too heavy to lift. You cannot safely stop yourself with your arms.

Section Review

9.1 Impulse and Momentum pages 229–235

page 235

6. **Momentum** Is the momentum of a car traveling south different from that of the same car when it travels north at the same speed? Draw the momentum vectors to support your answer.

Yes, momentum is a vector quantity, and the momenta of the two cars are in opposite directions.

Chapter 9 continued

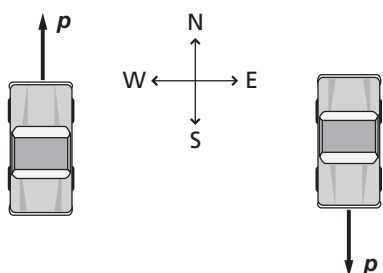

7. Impulse and Momentum When you jump from a height to the ground, you let your legs bend at the knees as your feet hit the floor. Explain why you do this in terms of the physics concepts introduced in this chapter.

You reduce the force by increasing the length of time it takes to stop the motion of your body.

8. Momentum Which has more momentum, a supertanker tied to a dock or a falling raindrop?

The raindrop has more momentum, because a supertanker at rest has zero momentum.

9. Impulse and Momentum A 0.174-kg softball is pitched horizontally at 26.0 m/s. The ball moves in the opposite direction at 38.0 m/s after it is hit by the bat.

a. Draw arrows showing the ball's momentum before and after the bat hits it.

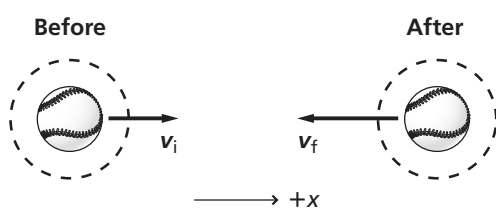

b. What is the change in momentum of the ball?

$$\begin{aligned} \Delta p &= m(v_f - v_i) \\ &= (0.174 \text{ kg}) \\ &\quad (38.0 \text{ m/s} - (-26.0 \text{ m/s})) \\ &= 11.1 \text{ kg}\cdot\text{m/s} \end{aligned}$$

c. What is the impulse delivered by the bat?

$$\begin{aligned} F\Delta t &= p_f - p_i \\ &= \Delta p \end{aligned}$$

$$\begin{aligned} &= 11.1 \text{ kg}\cdot\text{m/s} \\ &= 11.1 \text{ N}\cdot\text{s} \end{aligned}$$

d. If the bat and softball are in contact for 0.80 ms, what is the average force that the bat exerts on the ball?

$$\begin{aligned} F\Delta t &= m(v_f - v_i) \\ F &= \frac{m(v_f - v_i)}{\Delta t} \\ &= \frac{(0.174 \text{ kg})(38.0 \text{ m/s} - (-26.0 \text{ m/s}))}{(0.80 \text{ ms})\left(\frac{1 \text{ s}}{1000 \text{ ms}}\right)} \\ &= 1.4 \times 10^4 \text{ N} \end{aligned}$$

10. Momentum The speed of a basketball as it is dribbled is the same when the ball is going toward the floor as it is when the ball rises from the floor. Is the basketball's change in momentum equal to zero when it hits the floor? If not, in which direction is the change in momentum? Draw the basketball's momentum vectors before and after it hits the floor.

No, the change in momentum is upward. Before the ball hits the floor, its momentum vector is downward. After the ball hits the floor, its momentum vector is upward.

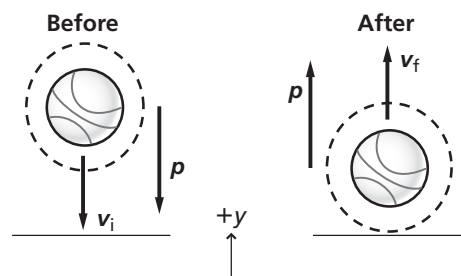

11. Angular Momentum An ice-skater spins with his arms outstretched. When he pulls his arms in and raises them above his head, he spins much faster than before. Did a torque act on the ice-skater? If not, how could his angular velocity have increased?

No torque acted on him. By drawing his arms in and keeping them close to the axis of rotation, he decreased his moment of inertia. Because the angular momentum did not change, the skater's angular velocity increased.

Chapter 9 continued

- 12. Critical Thinking** An archer shoots arrows at a target. Some of the arrows stick in the target, while others bounce off. Assuming that the masses of the arrows and the velocities of the arrows are the same, which arrows produce a bigger impulse on the target? *Hint: Draw a diagram to show the momentum of the arrows before and after hitting the target for the two instances.*

The ones that bounce off give more impulse because they end up with some momentum in the reverse direction, meaning they have a larger change in momentum.

Practice Problems

9.2 Conservation of Momentum pages 236–245

page 238

- 13.** Two freight cars, each with a mass of 3.0×10^5 kg, collide and stick together. One was initially moving at 2.2 m/s, and the other was at rest. What is their final speed?

$$p_i = p_f$$

$$mv_{Ai} + mv_{Bi} = 2mv_f$$

$$\begin{aligned} v_f &= \frac{v_{Ai} + v_{Bi}}{2} \\ &= \frac{2.2 \text{ m/s} + 0.0 \text{ m/s}}{2} \\ &= 1.1 \text{ m/s} \end{aligned}$$

- 14.** A 0.105-kg hockey puck moving at 24 m/s is caught and held by a 75-kg goalie at rest. With what speed does the goalie slide on the ice?

$$p_{Pi} + p_{Gi} = p_{Pf} + p_{Gf}$$

$$m_P v_{Pi} + m_G v_{Gi} = m_P v_{Pf} + m_G v_{Gf}$$

Because $v_{Gi} = 0.0$ kg·m/s,

$$m_P v_{Pi} = (m_P + m_G) v_f$$

where $v_f = v_{Pf} = v_{Gf}$ is the common final speed of the goalie and the puck.

$$\begin{aligned} v_f &= \frac{m_P v_{Pi}}{(m_P + m_G)} \\ &= \frac{(0.105 \text{ kg})(24 \text{ m/s})}{(0.105 \text{ kg} + 75 \text{ kg})} = 0.034 \text{ m/s} \end{aligned}$$

- 15.** A 35.0-g bullet strikes a 5.0-kg stationary piece of lumber and embeds itself in the wood. The piece of lumber and bullet fly off together at 8.6 m/s. What was the original speed of the bullet?

$$m_b v_{bi} + m_w v_{wi} = (m_b + m_w) v_f$$

where v_f is the common final speed of the bullet and piece of lumber.

Because $v_{wi} = 0.0$ m/s,

$$\begin{aligned} v_{bi} &= \frac{(m_b + m_w) v_f}{m_b} \\ &= \frac{(0.0350 \text{ kg} + 5.0 \text{ kg})(8.6 \text{ m/s})}{0.0350 \text{ kg}} \\ &= 1.2 \times 10^3 \text{ m/s} \end{aligned}$$

- 16.** A 35.0-g bullet moving at 475 m/s strikes a 2.5-kg bag of flour that is on ice, at rest. The bullet passes through the bag, as shown in **Figure 9-7**, and exits it at 275 m/s. How fast is the bag moving when the bullet exits?



■ Figure 9-7

$$m_B v_{Bi} + m_F v_{Fi} = m_B v_{Bf} + m_F v_{Ff}$$

where $v_{Fi} = 0.0$ m/s

$$v_{Ff} = \frac{(m_B v_{Bi} - m_B v_{Bf})}{m_F}$$

$$v_{Ff} = \frac{m_B (v_{Bi} - v_{Bf})}{m_F}$$

Chapter 9 continued

$$= \frac{(0.0350 \text{ kg})(475 \text{ m/s} - 275 \text{ m/s})}{2.5 \text{ kg}}$$

$$= 2.8 \text{ m/s}$$

17. The bullet in the previous problem strikes a 2.5-kg steel ball that is at rest. The bullet bounces backward after its collision at a speed of 5.0 m/s. How fast is the ball moving when the bullet bounces backward?

The system is the bullet and the ball.

$$m_{\text{bullet}}v_{\text{bullet}, i} + m_{\text{ball}}v_{\text{ball}, i} = m_{\text{bullet}}v_{\text{bullet}, f} + m_{\text{ball}}v_{\text{ball}, f}$$

$$v_{\text{ball}, i} = 0.0 \text{ m/s and } v_{\text{bullet}, f} = -5.0 \text{ m/s}$$

$$\text{so } v_{\text{ball}, f} = \frac{m_{\text{bullet}}(v_{\text{bullet}, i} - v_{\text{bullet}, f})}{m_{\text{ball}}} = \frac{(0.0350 \text{ kg})(475 \text{ m/s} - (-5.0 \text{ m/s}))}{2.5 \text{ kg}}$$

$$= 6.7 \text{ m/s}$$

18. A 0.50-kg ball that is traveling at 6.0 m/s collides head-on with a 1.00-kg ball moving in the opposite direction at a speed of 12.0 m/s. The 0.50-kg ball bounces backward at 14 m/s after the collision. Find the speed of the second ball after the collision.

Say that the first ball (ball C) is initially moving in the positive (forward) direction.

$$m_{\text{C}}v_{\text{Ci}} + m_{\text{D}}v_{\text{Di}} = m_{\text{C}}v_{\text{Cf}} + m_{\text{D}}v_{\text{Df}}$$

$$\text{so } v_{\text{Df}} = \frac{m_{\text{C}}v_{\text{Ci}} + m_{\text{D}}v_{\text{Di}} - m_{\text{C}}v_{\text{Cf}}}{m_{\text{D}}}$$

$$= \frac{(0.50 \text{ kg})(6.0 \text{ m/s}) + (1.00 \text{ kg})(-12.0 \text{ m/s}) - (0.50 \text{ kg})(-14 \text{ m/s})}{1.00 \text{ kg}}$$

$$= -2.0 \text{ m/s, or } 2.0 \text{ m/s in the opposite direction}$$

page 240

19. A 4.00-kg model rocket is launched, expelling 50.0 g of burned fuel from its exhaust at a speed of 625 m/s. What is the velocity of the rocket after the fuel has burned? *Hint: Ignore the external forces of gravity and air resistance.*

$$p_{\text{ri}} + p_{\text{fuel}, i} = p_{\text{rf}} + p_{\text{fuel}, f}$$

$$\text{where } p_{\text{rf}} + p_{\text{fuel}, f} = 0.0 \text{ kg}\cdot\text{m/s}$$

If the initial mass of the rocket (including fuel) is $m_r = 4.00 \text{ kg}$, then the final mass of the rocket is

$$m_{\text{rf}} = 4.00 \text{ kg} - 0.0500 \text{ kg} = 3.95 \text{ kg}$$

$$0.0 \text{ kg}\cdot\text{m/s} = m_{\text{rf}}v_{\text{rf}} + m_{\text{fuel}}v_{\text{fuel}, f}$$

$$v_{\text{rf}} = \frac{-m_{\text{fuel}}v_{\text{fuel}, f}}{m_{\text{rf}}}$$

$$= \frac{-(0.0500 \text{ kg})(-625 \text{ m/s})}{3.95 \text{ kg}}$$

$$= 7.91 \text{ m/s}$$

Chapter 9 continued

- 20.** A thread holds a 1.5-kg cart and a 4.5-kg cart together. After the thread is burned, a compressed spring pushes the carts apart, giving the 1.5-kg cart a speed of 27 cm/s to the left. What is the velocity of the 4.5-kg cart?

Let the 1.5-kg cart be represented by “C” and the 4.5-kg cart be represented by “D”.

$$p_{Ci} + p_{Di} = p_{Cf} + p_{Df}$$

where $p_{Ci} = p_{Di} = 0.0 \text{ kg}\cdot\text{m/s}$

$$m_D v_{Df} = -m_C v_{Cf}$$

$$\begin{aligned} \text{so } v_{Df} &= \frac{-m_C v_{Cf}}{m_D} \\ &= \frac{-(1.5 \text{ kg})(-27 \text{ cm/s})}{4.5 \text{ kg}} \\ &= 9.0 \text{ cm/s to the right} \end{aligned}$$

- 21.** Carmen and Judi dock a canoe. 80.0-kg Carmen moves forward at 4.0 m/s as she leaves the canoe. At what speed and in what direction do the canoe and Judi move if their combined mass is 115 kg?

$$p_{Ci} + p_{Ji} = p_{Cf} + p_{Jf}$$

where $p_{Ci} = p_{Ji} = 0.0 \text{ kg}\cdot\text{m/s}$

$$m_C v_{Cf} = -m_J v_{Jf}$$

$$\begin{aligned} \text{so } v_{Jf} &= \frac{-m_C v_{Cf}}{m_J} \\ &= \frac{-(80.0 \text{ kg})(4.0 \text{ m/s})}{115 \text{ kg}} \\ &= 2.8 \text{ m/s in the opposite direction} \end{aligned}$$

page 243

- 22.** A 925-kg car moving north at 20.1 m/s collides with a 1865-kg car moving west at 13.4 m/s. The two cars are stuck together. In what direction and at what speed do they move after the collision?

Before:

$$\begin{aligned} p_{i,y} &= m_y v_{i,y} \\ &= (925 \text{ kg})(20.1 \text{ m/s}) \\ &= 1.86 \times 10^4 \text{ kg}\cdot\text{m/s} \end{aligned}$$

$$\begin{aligned} p_{i,x} &= m_x v_{i,x} \\ &= (1865 \text{ kg})(-13.4 \text{ m/s}) \\ &= -2.50 \times 10^4 \text{ kg}\cdot\text{m/s} \end{aligned}$$

$$p_{f,y} = p_{i,y}$$

$$p_{f,x} = p_{i,x}$$

$$\begin{aligned} p_f &= p_i \\ &= \sqrt{(p_{f,x})^2 + (p_{f,y})^2} \end{aligned}$$

Chapter 9 continued

$$= \sqrt{(-2.50 \times 10^4 \text{ kg}\cdot\text{m/s})^2 + (1.86 \times 10^4 \text{ kg}\cdot\text{m/s})^2}$$

$$= 3.12 \times 10^4 \text{ kg}\cdot\text{m/s}$$

$$v_f = \frac{p_f}{m_1 + m_2}$$

$$= \frac{3.12 \times 10^4 \text{ kg}\cdot\text{m/s}}{(925 \text{ kg} + 1865 \text{ kg})} = 11.2 \text{ m/s}$$

$$\theta = \tan^{-1}\left(\frac{p_{f,y}}{p_{f,x}}\right)$$

$$= \tan^{-1}\left(\frac{1.86 \times 10^4 \text{ kg}\cdot\text{m/s}}{-2.50 \times 10^4 \text{ kg}\cdot\text{m/s}}\right)$$

$$= 36.6^\circ \text{ north of west}$$

- 23.** A 1383-kg car moving south at 11.2 m/s is struck by a 1732-kg car moving east at 31.3 m/s. The cars are stuck together. How fast and in what direction do they move immediately after the collision?

Before:

$$p_{i,x} = p_{1,x} + p_{2,x}$$

$$= 0 + m_2 v_{2i}$$

$$p_{i,y} = p_{1,y} + p_{2,y}$$

$$= m_1 v_{1i} + 0$$

$$p_f = p_i$$

$$= \sqrt{p_{1,x}^2 + p_{i,y}^2}$$

$$= \sqrt{(m_2 v_{2i})^2 + (m_1 v_{1i})^2}$$

$$v_f = \frac{p_f}{m_1 + m_2}$$

$$= \frac{\sqrt{(m_2 v_{2i})^2 + (m_1 v_{1i})^2}}{m_1 + m_2}$$

$$= \frac{\sqrt{((1732 \text{ kg})(31.3 \text{ m/s}))^2 + ((1383 \text{ kg})(-11.2 \text{ m/s}))^2}}{1383 \text{ kg} + 1782 \text{ kg}}$$

$$= 18.1 \text{ m/s}$$

$$\theta = \tan^{-1}\left(\frac{p_{i,y}}{p_{i,x}}\right) = \tan^{-1}\left(\frac{m_1 v_{1i}}{m_2 v_{2i}}\right) = \tan^{-1}\left(\frac{(1383 \text{ kg})(-11.2 \text{ m/s})}{(1732 \text{ kg})(31.3 \text{ m/s})}\right) = 15.9^\circ$$

south of east

- 24.** A stationary billiard ball, with a mass of 0.17 kg, is struck by an identical ball moving at 4.0 m/s. After the collision, the second ball moves 60.0° to the left of its original direction. The stationary ball moves 30.0° to the right of the moving ball's original direction. What is the velocity of each ball after the collision?

$$p_{Ci} + p_{Di} = p_{Cf} + p_{Df}$$

$$\text{where } p_{Ci} = 0.0 \text{ kg}\cdot\text{m/s}$$

$$m_C = m_D = m = 0.17 \text{ kg}$$

Chapter 9 continued

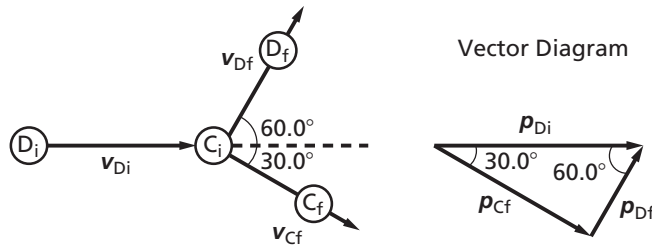

The vector diagram provides final momentum equations for the ball that is initially stationary, C, and the ball that is initially moving, D.

$$p_{Cf} = p_{Di} \sin 60.0^\circ$$

$$p_{Df} = p_{Di} \cos 60.0^\circ$$

We can use the momentum equation for the stationary ball to find its final velocity.

$$p_{Cf} = p_{Di} \sin 60.0^\circ$$

$$mv_{Cf} = mv_{Di} \sin 60.0^\circ$$

$$v_{Cf} = v_{Di} \sin 60.0^\circ$$

$$= (4.0 \text{ m/s})(\sin 60.0^\circ)$$

$$= 3.5 \text{ m/s}, 30.0^\circ \text{ to the right}$$

We can use the momentum equation for the moving ball to find its velocity.

$$p_{Df} = p_{Di} \cos 60.0^\circ$$

$$mv_{Df} = mv_{Di} \cos 60.0^\circ$$

$$v_{Df} = v_{Di} \cos 60.0^\circ$$

$$= (4.0 \text{ m/s})(\cos 60.0^\circ)$$

$$= 2.0 \text{ m/s}, 60.0^\circ \text{ to the left}$$

25. A 1345-kg car moving east at 15.7 m/s is struck by a 1923-kg car moving north. They are stuck together and move with an initial velocity of 14.5 m/s at $\theta = 63.5^\circ$. Was the north-moving car exceeding the 20.1 m/s speed limit?

Before:

$$p_{i,x} = m_1 v_{1,i}$$

$$= (1345 \text{ kg})(15.7 \text{ m/s})$$

$$= 2.11 \times 10^4 \text{ kg}\cdot\text{m/s}$$

$$p_f = p_i$$

$$= (m_1 + m_2)v_f$$

$$= (1345 \text{ kg} + 1923 \text{ kg})(14.5 \text{ m/s})$$

$$= 4.74 \times 10^4 \text{ kg}\cdot\text{m/s}$$

$$p_{f,y} = p_f \sin \theta$$

$$= (4.74 \times 10^4 \text{ kg}\cdot\text{m/s})(\sin 63.5^\circ)$$

$$= 4.24 \times 10^4 \text{ kg}\cdot\text{m/s}$$

Chapter 9 continued

$$p_{f,y} = p_{i,y} = m_2 v_{2,i}$$

$$v_{2,i} = \frac{p_{f,y}}{m_2} = \frac{4.24 \times 10^4 \text{ kg}\cdot\text{m/s}}{1923 \text{ kg}}$$

$$= 22.1 \text{ m/s}$$

Yes, it was exceeding the speed limit.

Section Review

9.2 Conservation of Momentum pages 236–245

page 245

26. Angular Momentum The outer rim of a plastic disk is thick and heavy. Besides making it easier to catch, how does this affect the rotational properties of the plastic disk?

Most of the mass of the disk is located at the rim, thereby increasing its moment of inertia. Therefore, when the disk is spinning, its angular momentum is larger than it would be if more mass were near the center. With a larger angular momentum, the disk flies through the air with more stability.

27. Speed A cart, weighing 24.5 N, is released from rest on a 1.00-m ramp, inclined at an angle of 30.0° as shown in **Figure 9-14**. The cart rolls down the incline and strikes a second cart weighing 36.8 N.

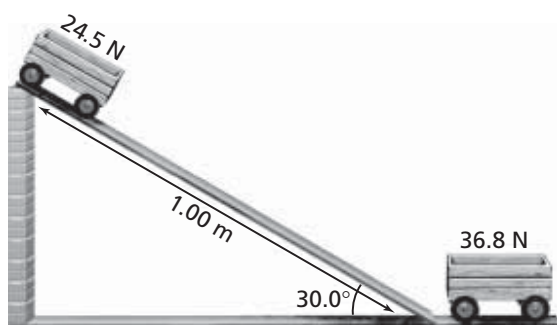

■ Figure 9-14

- a. Calculate the speed of the first cart at the bottom of the incline.

The force parallel to the surface of the ramp is

$$F_{\parallel} = F_g \sin \theta$$

where

$$a = \frac{F_{\parallel}}{m} \text{ and } m = \frac{F_g}{g}$$

$$\text{so, } a = \frac{F_g \sin \theta}{F_g/g} = g \sin \theta$$

The velocity and acceleration of the cart are related by the motion equation, $v^2 = v_i^2 + 2a(d - d_i)$ with $v_i = 0$ and $d_i = 0$. Thus,

$$v^2 = 2ad$$

$$v = \sqrt{2ad}$$

$$= \sqrt{(2)(g \sin \theta)(d)}$$

$$= \sqrt{(2)(9.80 \text{ m/s}^2)(\sin 30.0^\circ)(1.00 \text{ m})}$$

$$= 3.13 \text{ m/s}$$

- b. If the two carts stick together, with what initial speed will they move along?

$$m_C v_{Ci} = (m_C + m_D) v_f$$

$$\text{so, } v_f = \frac{m_C v_{Ci}}{m_C + m_D}$$

$$= \left(\frac{F_C}{g}\right) v_{Ci}$$

$$= \frac{F_C + F_D}{g}$$

$$= \frac{F_C v_{Ci}}{F_C + F_D}$$

$$= \frac{(24.5 \text{ N})(3.13 \text{ m/s})}{24.5 \text{ N} + 36.8 \text{ N}}$$

$$= 1.25 \text{ m/s}$$

28. Conservation of Momentum During a tennis serve, the racket of a tennis player continues forward after it hits the ball. Is momentum conserved in the collision? Explain, making sure that you define the system.

No, because the mass of the racket is much larger than that of the ball, only a small change in its velocity is required. In addition, it is being held by a massive, moving arm that is attached to a body in contact with Earth. Thus, the racket and ball do not comprise an isolated system.

29. Momentum A pole-vaulter runs toward the

Chapter 9 continued

launch point with horizontal momentum. Where does the vertical momentum come from as the athlete vaults over the crossbar?

The vertical momentum comes from the impulsive force of Earth against the pole. Earth acquires an equal and opposite vertical momentum.

30. Initial Momentum During a soccer game, two players come from opposite directions and collide when trying to head the ball. They come to rest in midair and fall to the ground. Describe their initial momenta.

Because their final momenta are zero, their initial momenta were equal and opposite.

31. Critical Thinking You catch a heavy ball while you are standing on a skateboard, and then you roll backward. If you were standing on the ground, however, you would be able to avoid moving while catching the ball. Explain both situations using the law of conservation of momentum. Explain which system you use in each case.

In the case of the skateboard, the ball, the skateboard, and you are an isolated system, and the momentum of the ball is shared. In the second case, unless Earth is included, there is an external force, so momentum is not conserved. If Earth's large mass is included in the system, the change in its velocity is negligible.

Chapter Assessment
Concept Mapping

page 250

32. Complete the following concept map using the following terms: *mass, momentum, average force, time over which the force is exerted.*

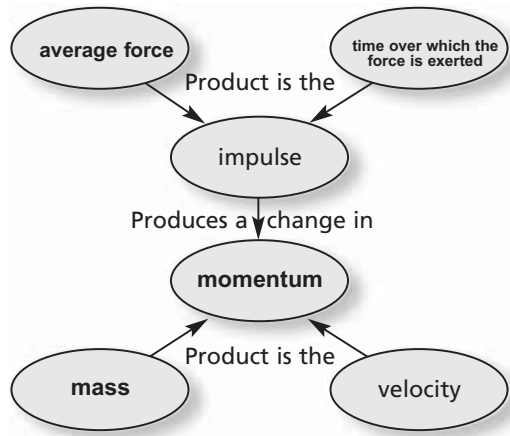

Mastering Concepts

page 250

33. Can a bullet have the same momentum as a truck? Explain. (9.1)

Yes, for a bullet to have the same momentum as a truck, it must have a higher velocity because the two masses are not the same.

$$m_{\text{bullet}}v_{\text{bullet}} = m_{\text{truck}}v_{\text{truck}}$$

34. A pitcher throws a curve ball to the catcher. Assume that the speed of the ball doesn't change in flight. (9.1)

a. Which player exerts the larger impulse on the ball?

The pitcher and the catcher exert the same amount of impulse on the ball, but the two impulses are in opposite directions.

b. Which player exerts the larger force on the ball?

The catcher exerts the larger force on the ball because the time interval over which the force is exerted is smaller.

35. Newton's second law of motion states that if no net force is exerted on a system, no acceleration is possible. Does it follow that no change in momentum can occur? (9.1)

No net force on the system means no net impulse on the system and no net change in momentum. However, individual parts of the system may have a

Chapter 9 continued

change in momentum as long as the net change in momentum is zero.

36. Why are cars made with bumpers that can be pushed in during a crash? (9.1)

Cars are made with bumpers that compress during a crash to increase the time of a collision, thereby reducing the force.

37. An ice-skater is doing a spin. (9.1)

- a. How can the skater's angular momentum be changed?

by applying an external torque

- b. How can the skater's angular velocity be changed without changing the angular momentum?

by changing the moment of inertia

38. What is meant by "an isolated system?" (9.2)

An isolated system has no external forces acting on it.

39. A spacecraft in outer space increases its velocity by firing its rockets. How can hot gases escaping from its rocket engine change the velocity of the craft when there is nothing in space for the gases to push against? (9.2)

Momentum is conserved. The change in momentum of gases in one direction must be balanced by an equal change in momentum of the spacecraft in the opposite direction.

40. A cue ball travels across a pool table and collides with the stationary eight ball. The two balls have equal masses. After the collision, the cue ball is at rest. What must be true regarding the speed of the eight ball? (9.2)

The eight ball must be moving with the same velocity that the cue ball had just before the collision.

41. Consider a ball falling toward Earth. (9.2)

- a. Why is the momentum of the ball not conserved?

The momentum of a falling ball is not conserved because a net external force, gravity, is acting on it.

- b. In what system that includes the falling ball is the momentum conserved?

One such system in which total momentum is conserved includes the ball plus Earth.

42. A falling basketball hits the floor. Just before it hits, the momentum is in the downward direction, and after it hits the floor, the momentum is in the upward direction. (9.2)

- a. Why isn't the momentum of the basketball conserved even though the bounce is a collision?

The floor is outside the system, so it exerts an external force, and therefore, an impulse on the ball.

- b. In what system is the momentum conserved?

Momentum is conserved in the system of ball plus Earth.

43. Only an external force can change the momentum of a system. Explain how the internal force of a car's brakes brings the car to a stop. (9.2)

The external force of a car's brakes can bring the car to a stop by stopping the wheels and allowing the external frictional force of the road against the tires to stop the car. If there is no friction—for example, if the road is icy—then there is no external force and the car does not stop.

44. Children's playgrounds often have circular-motion rides. How could a child change the angular momentum of such a ride as it is turning? (9.2)

The child would have to exert a torque on it. He or she could stand next to it and exert a force tangential to the circle on the handles as they go past. He or she also could run at the ride and jump onboard.

Chapter 9 continued

Applying Concepts

pages 250–251

45. Explain the concept of impulse using physical ideas rather than mathematics.

A force, F , exerted on an object over a time, Δt , causes the momentum of the object to change by the quantity $F\Delta t$.

46. Is it possible for an object to obtain a larger impulse from a smaller force than it does from a larger force? Explain.

Yes, if the smaller force acts for a long enough time, it can provide a larger impulse.

47. **Foul Ball** You are sitting at a baseball game when a foul ball comes in your direction. You prepare to catch it bare-handed. To catch it safely, should you move your hands toward the ball, hold them still, or move them in the same direction as the moving ball? Explain.

You should move your hands in the same direction the ball is traveling to increase the time of the collision, thereby reducing the force.

48. A 0.11-g bullet leaves a pistol at 323 m/s, while a similar bullet leaves a rifle at 396 m/s. Explain the difference in exit speeds of the two bullets, assuming that the forces exerted on the bullets by the expanding gases have the same magnitude.

The bullet is in the rifle a longer time, so the momentum it gains is larger.

49. An object initially at rest experiences the impulses described by the graph in **Figure 9-15**. Describe the object's motion after impulses A, B, and C.

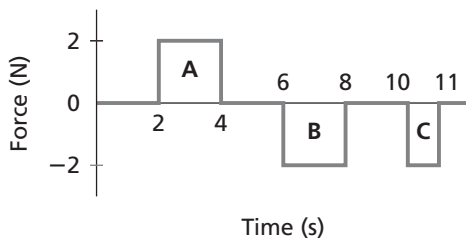

■ Figure 9-15

After time A, the object moves with a constant, positive velocity. After time B, the object is at rest. After time C, the object moves with a constant, negative velocity.

50. During a space walk, the tether connecting an astronaut to the spaceship breaks. Using a gas pistol, the astronaut manages to get back to the ship. Use the language of the impulse-momentum theorem and a diagram to explain why this method was effective.

When the gas pistol is fired in the opposite direction, it provides the impulse needed to move the astronaut toward the spaceship.

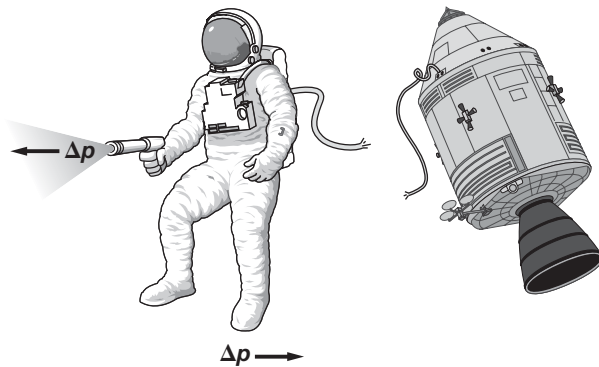

51. **Tennis Ball** As a tennis ball bounces off a wall, its momentum is reversed. Explain this action in terms of the law of conservation of momentum. Define the system and draw a diagram as a part of your explanation.

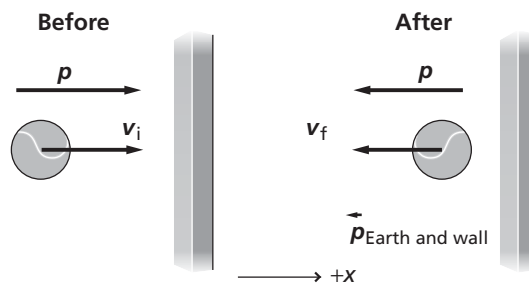

Consider the system to be the ball, the wall, and Earth. The wall and Earth gain some momentum in the collision.

52. Imagine that you command spaceship *Zeldon*, which is moving through interplanetary space at high speed. How could you

Chapter 9 continued

slow your ship by applying the law of conservation of momentum?

By shooting mass in the form of exhaust gas, at high velocity in the same direction in which you are moving, its momentum would cause the ship's momentum to decrease.

53. Two trucks that appear to be identical collide on an icy road. One was originally at rest. The trucks are stuck together and move at more than half the original speed of the moving truck. What can you conclude about the contents of the two trucks?

If the two trucks had equal masses, they would have moved off at half the speed of the moving truck. Thus, the moving truck must have had a more massive load.

54. Explain, in terms of impulse and momentum, why it is advisable to place the butt of a rifle against your shoulder when first learning to shoot.

When held loosely, the recoil momentum of the rifle works against only the mass of the rifle, thereby producing a larger velocity and striking your shoulder. The recoil momentum must work against the mass of the rifle and you, resulting in a smaller velocity.

55. **Bullets** Two bullets of equal mass are shot at equal speeds at blocks of wood on a smooth ice rink. One bullet, made of rubber, bounces off of the wood. The other bullet, made of aluminum, burrows into the wood. In which case does the block of wood move faster? Explain.

Momentum is conserved, so the momentum of the block and bullet after the collision equals the momentum of the bullet before the collision. The rubber bullet has a negative momentum after impact, with respect to the block, so the block's momentum must be greater in this case.

Mastering Problems

9.1 Impulse and Momentum

pages 251–252

Level 1

56. **Golf** Rocío strikes a 0.058-kg golf ball with a force of 272 N and gives it a velocity of 62.0 m/s. How long was Rocío's club in contact with the ball?

$$\begin{aligned}\Delta t &= \frac{m\Delta v}{F} = \frac{(0.058 \text{ kg})(62.0 \text{ m/s})}{272 \text{ N}} \\ &= 0.013 \text{ s}\end{aligned}$$

57. A 0.145-kg baseball is pitched at 42 m/s. The batter hits it horizontally to the pitcher at 58 m/s.

- a. Find the change in momentum of the ball.

Take the direction of the pitch to be positive.

$$\begin{aligned}\Delta p &= mv_f - mv_i = m(v_f - v_i) \\ &= (0.145 \text{ kg})(-58 \text{ m/s} - (+42 \text{ m/s})) \\ &= -14 \text{ kg}\cdot\text{m/s}\end{aligned}$$

- b. If the ball and bat are in contact for 4.6×10^{-4} s, what is the average force during contact?

$$\begin{aligned}F\Delta t &= \Delta p \\ F &= \frac{\Delta p}{\Delta t} \\ &= \frac{m(v_f - v_i)}{\Delta t} \\ &= \frac{(0.145 \text{ kg})(-58 \text{ m/s} - (+42 \text{ m/s}))}{4.6 \times 10^{-4} \text{ s}} \\ &= -3.2 \times 10^4 \text{ N}\end{aligned}$$

58. **Bowling** A force of 186 N acts on a 7.3-kg bowling ball for 0.40 s. What is the bowling ball's change in momentum? What is its change in velocity?

$$\begin{aligned}\Delta p &= F\Delta t \\ &= (186 \text{ N})(0.40 \text{ s}) \\ &= 74 \text{ N}\cdot\text{s} \\ &= 74 \text{ kg}\cdot\text{m/s} \\ \Delta v &= \frac{\Delta p}{m} \\ &= \frac{F\Delta t}{m}\end{aligned}$$

Chapter 9 continued

$$= \frac{(186 \text{ N})(0.40 \text{ s})}{7.3 \text{ kg}}$$

$$= 1.0 \times 10^1 \text{ m/s}$$

59. A 5500-kg freight truck accelerates from 4.2 m/s to 7.8 m/s in 15.0 s by the application of a constant force.

- a. What change in momentum occurs?

$$\Delta p = m\Delta v = m(v_f - v_i)$$

$$= (5500 \text{ kg})(7.8 \text{ m/s} - 4.2 \text{ m/s})$$

$$= 2.0 \times 10^4 \text{ kg}\cdot\text{m/s}$$

- b. How large of a force is exerted?

$$F = \frac{\Delta p}{\Delta t}$$

$$= \frac{m(v_f - v_i)}{\Delta t}$$

$$= \frac{(5500 \text{ kg})(7.8 \text{ m/s} - 4.2 \text{ m/s})}{15.0 \text{ s}}$$

$$= 1.3 \times 10^3 \text{ N}$$

60. In a ballistics test at the police department, Officer Rios fires a 6.0-g bullet at 350 m/s into a container that stops it in 1.8 ms. What is the average force that stops the bullet?

$$F = \frac{\Delta p}{\Delta t}$$

$$= \frac{m(v_f - v_i)}{\Delta t}$$

$$= \frac{(0.0060 \text{ kg})(0.0 \text{ m/s} - 350 \text{ m/s})}{1.8 \times 10^{-3} \text{ s}}$$

$$= -1.2 \times 10^3 \text{ N}$$

61. **Volleyball** A 0.24-kg volleyball approaches Tina with a velocity of 3.8 m/s. Tina bumps the ball, giving it a speed of 2.4 m/s but in the opposite direction. What average force did she apply if the interaction time between her hands and the ball was 0.025 s?

$$F = \frac{m\Delta v}{\Delta t}$$

$$= \frac{(0.24 \text{ kg})(-2.4 \text{ m/s} - 3.8 \text{ m/s})}{0.025 \text{ s}}$$

$$= -6.0 \times 10^1 \text{ N}$$

62. **Hockey** A hockey player makes a slap shot, exerting a constant force of 30.0 N on the hockey puck for 0.16 s. What is the magnitude of the impulse given to the puck?

$$F\Delta t = (30.0 \text{ N})(0.16 \text{ s})$$

$$= 4.8 \text{ N}\cdot\text{s}$$

63. **Skateboarding** Your brother's mass is 35.6 kg, and he has a 1.3-kg skateboard. What is the combined momentum of your brother and his skateboard if they are moving at 9.50 m/s?

$$p = mv$$

$$= (m_{\text{boy}} + m_{\text{board}})v$$

$$= (35.6 \text{ kg} + 1.3 \text{ kg})(9.50 \text{ m/s})$$

$$= 3.5 \times 10^2 \text{ kg}\cdot\text{m/s}$$

64. A hockey puck has a mass of 0.115 kg and is at rest. A hockey player makes a shot, exerting a constant force of 30.0 N on the puck for 0.16 s. With what speed does it head toward the goal?

$$F\Delta t = m\Delta v = m(v_f - v_i)$$

where $v_i = 0$

$$\text{Thus } v_f = \frac{F\Delta t}{m}$$

$$= \frac{(30.0 \text{ N})(0.16 \text{ s})}{0.115 \text{ kg}}$$

$$= 42 \text{ m/s}$$

65. Before a collision, a 25-kg object was moving at +12 m/s. Find the impulse that acted on the object if, after the collision, it moved at the following velocities.

- a. +8.0 m/s

$$F\Delta t = m\Delta v = m(v_f - v_i)$$

$$= (25 \text{ kg})(8.0 \text{ m/s} - 12 \text{ m/s})$$

$$= -1.0 \times 10^2 \text{ kg}\cdot\text{m/s}$$

- b. -8.0 m/s

$$F\Delta t = m\Delta v = m(v_f - v_i)$$

$$= (25 \text{ kg})(-8.0 \text{ m/s} - 12 \text{ m/s})$$

$$= -5.0 \times 10^2 \text{ kg}\cdot\text{m/s}$$

Chapter 9 continued

Level 2

- 66.** A 0.150-kg ball, moving in the positive direction at 12 m/s, is acted on by the impulse shown in the graph in **Figure 9-16**. What is the ball's speed at 4.0 s?

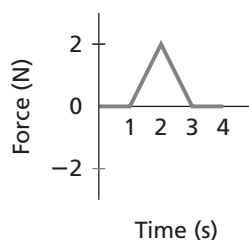

■ **Figure 9-16**

$$F\Delta t = m\Delta v$$

$$\text{Area of graph} = m\Delta v$$

$$\frac{1}{2}(2.0 \text{ N})(2.0 \text{ s}) = m(v_f - v_i)$$

$$2.0 \text{ N}\cdot\text{s} = (0.150 \text{ kg})(v_f - 12 \text{ m/s})$$

$$v_f = \frac{2.0 \text{ kg}\cdot\text{m/s}}{0.150 \text{ kg}} + 12 \text{ m/s}$$

$$= 25 \text{ m/s}$$

- 67. Baseball** A 0.145-kg baseball is moving at 35 m/s when it is caught by a player.

- a. Find the change in momentum of the ball.

$$\Delta p = m(v_f - v_i)$$

$$= (0.145 \text{ kg})(0.0 \text{ m/s} - 35 \text{ m/s})$$

$$= -5.1 \text{ kg}\cdot\text{m/s}$$

- b. If the ball is caught with the mitt held in a stationary position so that the ball stops in 0.050 s, what is the average force exerted on the ball?

$$\Delta p = F_{\text{average}}\Delta t$$

$$\text{so, } F_{\text{average}} = \frac{\Delta p}{\Delta t} = \frac{m(v_f - v_i)}{\Delta t}$$

$$= \frac{(0.145 \text{ kg})(0.0 \text{ m/s} - 35 \text{ m/s})}{0.500 \text{ s}}$$

$$= -1.0 \times 10^2 \text{ N}$$

- c. If, instead, the mitt is moving backward so that the ball takes 0.500 s to stop, what is the average force exerted by the mitt on the ball?

$$\Delta p = F_{\text{average}}\Delta t$$

$$\text{so, } F_{\text{average}} = \frac{\Delta p}{\Delta t} = \frac{m(v_f - v_i)}{\Delta t}$$

$$= \frac{(0.145 \text{ kg})(0.0 \text{ m/s} - 35 \text{ m/s})}{0.500 \text{ s}}$$

$$= -1.0 \times 10^1 \text{ N}$$

- 68. Hockey** A hockey puck has a mass of 0.115 kg and strikes the pole of the net at 37 m/s. It bounces off in the opposite direction at 25 m/s, as shown in **Figure 9-17**.

- a. What is the impulse on the puck?

$$F\Delta t = m(v_f - v_i)$$

$$= (0.115 \text{ kg})(-25 \text{ m/s} - 37 \text{ m/s})$$

$$= -7.1 \text{ kg}\cdot\text{m/s}$$

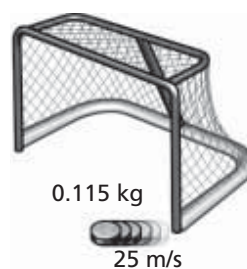

■ **Figure 9-17**

Chapter 9 continued

- b. If the collision takes 5.0×10^{-4} s, what is the average force on the puck?

$$F\Delta t = m(v_f - v_i)$$

$$F = \frac{m(v_f - v_i)}{\Delta t}$$

$$= \frac{(0.115 \text{ kg})(-25 \text{ m/s} - 37 \text{ m/s})}{5.0 \times 10^{-4} \text{ s}}$$

$$= -1.4 \times 10^4 \text{ N}$$

69. A nitrogen molecule with a mass of 4.7×10^{-26} kg, moving at 550 m/s, strikes the wall of a container and bounces back at the same speed.

- a. What is the impulse the molecule delivers to the wall?

$$F\Delta t = m(v_f - v_i)$$

$$= (4.7 \times 10^{-26} \text{ kg})(-550 \text{ m/s} - 550 \text{ m/s})$$

$$= -5.2 \times 10^{-23} \text{ kg}\cdot\text{m/s}$$

The impulse the wall delivers to the molecule is -5.2×10^{-23} kg·m/s.

The impulse the molecule delivers to the wall is $+5.2 \times 10^{-23}$ kg·m/s.

- b. If there are 1.5×10^{23} collisions each second, what is the average force on the wall?

$$F\Delta t = m(v_f - v_i)$$

$$F = \frac{m(v_f - v_i)}{\Delta t}$$

For all the collisions, the force is

$$F_{\text{total}} = (1.5 \times 10^{23}) \frac{m(v_f - v_i)}{\Delta t}$$

$$= (1.5 \times 10^{23}) \frac{(4.7 \times 10^{-26} \text{ kg})(-550 \text{ m/s} - 550 \text{ m/s})}{1.0 \text{ s}}$$

$$= 7.8 \text{ N}$$

Level 3

70. **Rockets** Small rockets are used to make tiny adjustments in the speeds of satellites. One such rocket has a thrust of 35 N. If it is fired to change the velocity of a 72,000-kg spacecraft by 63 cm/s, how long should it be fired?

$$F\Delta t = m\Delta v$$

$$\text{so, } \Delta t = \frac{m\Delta v}{F}$$

$$= \frac{(72,000 \text{ kg})(0.63 \text{ m/s})}{35 \text{ N}}$$

$$= 1.3 \times 10^3 \text{ s, or 22 min}$$

Chapter 9 continued

- 71.** An animal rescue plane flying due east at 36.0 m/s drops a bale of hay from an altitude of 60.0 m, as shown in **Figure 9-18**. If the bale of hay weighs 175 N, what is the momentum of the bale the moment before it strikes the ground? Give both magnitude and direction.

First use projectile motion to find the velocity of the bale.

$$p = mv$$

To find v , consider the horizontal and vertical components.

$$v_x = 36.0 \text{ m/s}$$

$$v_y^2 = v_{iy}^2 + 2dg = 2dg$$

Thus,

$$v = \sqrt{v_x^2 + v_y^2} = \sqrt{v_x^2 + 2dg}$$

The momentum, then, is

$$\begin{aligned} p &= \frac{F_g v}{g} = \frac{F_g \sqrt{v_x^2 + 2dg}}{g} \\ &= \frac{(175 \text{ N}) \sqrt{(36.0 \text{ m/s})^2 + (2)(60.0 \text{ m})(9.80 \text{ m/s}^2)}}{9.80 \text{ m/s}^2} \\ &= 888 \text{ kg}\cdot\text{m/s} \end{aligned}$$

The angle from the horizontal is

$$\begin{aligned} \tan \theta &= \frac{v_y}{v_x} \\ &= \frac{\sqrt{2dg}}{v_x} \\ &= \frac{\sqrt{(2)(60.0 \text{ m})(9.80 \text{ m/s}^2)}}{36.0 \text{ m/s}} \\ &= 43.6^\circ \end{aligned}$$

- 72. Accident** A car moving at 10.0 m/s crashes into a barrier and stops in 0.050 s. There is a 20.0-kg child in the car. Assume that the child's velocity is changed by the same amount as that of the car, and in the same time period.

- a.** What is the impulse needed to stop the child?

$$\begin{aligned} F\Delta t &= m\Delta v = m(v_f - v_i) \\ &= (20.0 \text{ kg})(0.0 \text{ m/s} - 10.0 \text{ m/s}) \\ &= -2.00 \times 10^2 \text{ kg}\cdot\text{m/s} \end{aligned}$$

- b.** What is the average force on the child?

$$\begin{aligned} F\Delta t &= m\Delta v = m(v_f - v_i) \\ \text{so, } F &= \frac{m(v_f - v_i)}{\Delta t} \\ &= \frac{(20.0 \text{ kg})(0.0 \text{ m/s} - 10.0 \text{ m/s})}{0.050 \text{ s}} \\ &= -4.0 \times 10^3 \text{ N} \end{aligned}$$

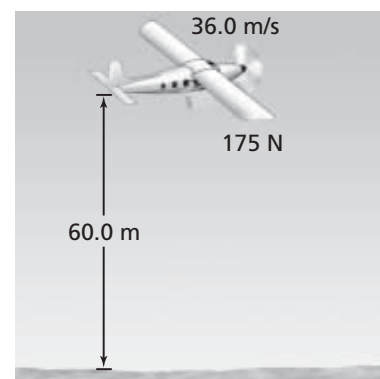

■ Figure 9-18

Chapter 9 continued

- c. What is the approximate mass of an object whose weight equals the force in part **b**?

$$F_g = mg$$

$$\text{so, } m = \frac{F_g}{g} = \frac{4.0 \times 10^3 \text{ N}}{9.80 \text{ m/s}^2}$$

$$= 4.1 \times 10^2 \text{ kg}$$

- d. Could you lift such a weight with your arm?

No.

- e. Why is it advisable to use a proper restraining seat rather than hold a child on your lap?

You would not be able to protect a child on your lap in the event of a collision.

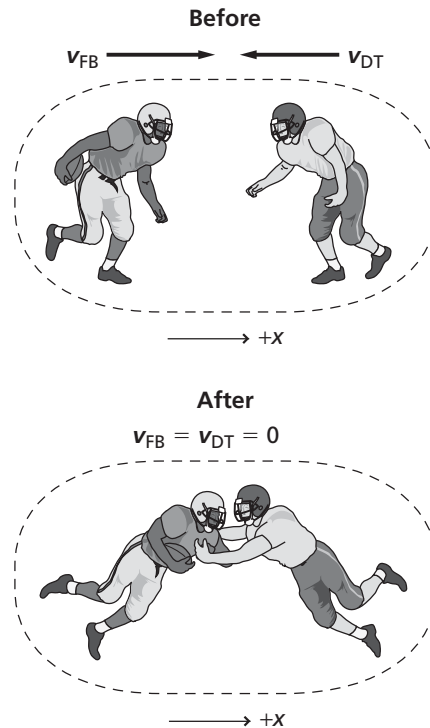

9.2 Conservation of Momentum

pages 252–253

Level 1

- 73. Football** A 95-kg fullback, running at 8.2 m/s, collides in midair with a 128-kg defensive tackle moving in the opposite direction. Both players end up with zero speed.

- a. Identify the “before” and “after” situations and draw a diagram of both.

Before: $m_{FB} = 95 \text{ kg}$

$$v_{FB} = 8.2 \text{ m/s}$$

$$m_{DT} = 128 \text{ kg}$$

$$v_{DT} = ?$$

After: $m = 223 \text{ kg}$

$$v_f = 0 \text{ m/s}$$

- b. What was the fullback’s momentum before the collision?

$$p_{FB} = m_{FB}v_{FB} = (95 \text{ kg})(8.2 \text{ m/s})$$

$$= 7.8 \times 10^2 \text{ kg}\cdot\text{m/s}$$

- c. What was the change in the fullback’s momentum?

$$\Delta p_{FB} = p_f - p_{FB}$$

$$= 0 - p_{FB} = -7.8 \times 10^2 \text{ kg}\cdot\text{m/s}$$

- d. What was the change in the defensive tackle’s momentum?

$$+7.8 \times 10^2 \text{ kg}\cdot\text{m/s}$$

- e. What was the defensive tackle’s original momentum?

$$-7.8 \times 10^2 \text{ kg}\cdot\text{m/s}$$

- f. How fast was the defensive tackle moving originally?

$$m_{DT}v_{DT} = -7.8 \times 10^2 \text{ kg}\cdot\text{m/s}$$

$$\text{so, } v_{DT} = \frac{-7.8 \times 10^2 \text{ kg}\cdot\text{m/s}}{128 \text{ kg}}$$

$$= -6.1 \text{ m/s}$$

Chapter 9 continued

74. Marble C, with mass 5.0 g, moves at a speed of 20.0 cm/s. It collides with a second marble, D, with mass 10.0 g, moving at 10.0 cm/s in the same direction. After the collision, marble C continues with a speed of 8.0 cm/s in the same direction.

a. Sketch the situation and identify the system. Identify the "before" and "after" situations and set up a coordinate system.

Before: $m_C = 5.0 \text{ g}$

$m_D = 10.0 \text{ g}$

$v_{Ci} = 20.0 \text{ cm/s}$

$v_{Di} = 10.0 \text{ cm/s}$

After: $m_C = 5.0 \text{ g}$

$m_D = 10.0 \text{ g}$

$v_{Cf} = 8.0 \text{ cm/s}$

$v_{Df} = ?$

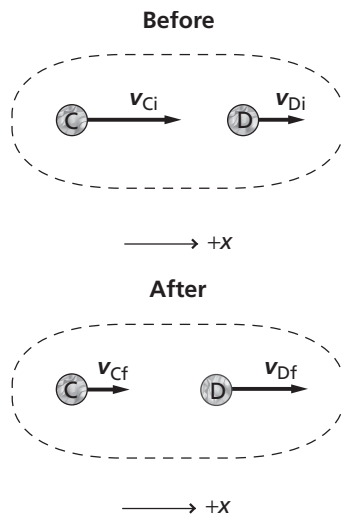

b. Calculate the marbles' momenta before the collision.

$$m_C v_{Ci} = (5.0 \times 10^{-3} \text{ kg})(0.200 \text{ m/s})$$

$$= 1.0 \times 10^{-3} \text{ kg}\cdot\text{m/s}$$

$$m_D v_{Di} = (1.00 \times 10^{-2} \text{ kg})(0.100 \text{ m/s})$$

$$= 1.0 \times 10^{-3} \text{ kg}\cdot\text{m/s}$$

c. Calculate the momentum of marble C after the collision.

$$m_C v_{Cf} = (5.0 \times 10^{-3} \text{ kg})(0.080 \text{ m/s})$$

$$= 4.0 \times 10^{-4} \text{ kg}\cdot\text{m/s}$$

d. Calculate the momentum of marble D after the collision.

$$p_{Ci} + p_{Di} = p_{Cf} + p_{Df}$$

$$p_{Df} = p_{Ci} + p_{Di} - p_{Cf}$$

$$= 1.00 \times 10^{-3} \text{ kg}\cdot\text{m/s} +$$

$$1.00 \times 10^{-3} \text{ kg}\cdot\text{m/s} -$$

$$4.0 \times 10^{-4} \text{ kg}\cdot\text{m/s}$$

$$= 1.6 \times 10^{-3} \text{ kg}\cdot\text{m/s}$$

e. What is the speed of marble D after the collision?

$$p_{Df} = m_D v_{Df}$$

$$\text{so, } v_{Df} = \frac{p_{Df}}{m_D}$$

$$= \frac{1.6 \times 10^{-3} \text{ kg}\cdot\text{m/s}}{1.00 \times 10^{-2} \text{ kg}}$$

$$= 1.6 \times 10^{-1} \text{ m/s} = 0.16 \text{ m/s}$$

$$= 16 \text{ cm/s}$$

75. Two lab carts are pushed together with a spring mechanism compressed between them. Upon release, the 5.0-kg cart repels one way with a velocity of 0.12 m/s, while the 2.0-kg cart goes in the opposite direction. What is the velocity of the 2.0-kg cart?

$$m_1 v_i = -m_2 v_f$$

$$v_f = \frac{m_1 v_i}{-m_2}$$

$$= \frac{(5.0 \text{ kg})(0.12 \text{ m/s})}{-(2.0 \text{ kg})}$$

$$= -0.30 \text{ m/s}$$

76. A 50.0-g projectile is launched with a horizontal velocity of 647 m/s from a 4.65-kg launcher moving in the same direction at 2.00 m/s. What is the launcher's velocity after the launch?

$$p_{Ci} + p_{Di} = p_{Cf} + p_{Df}$$

$$m_C v_{Ci} + m_D v_{Di} = m_C v_{Cf} + m_D v_{Df}$$

$$\text{so, } v_{Df} = \frac{m_C v_{Ci} + m_D v_{Di} - m_C v_{Cf}}{m_D}$$

Assuming that the projectile, C, is launched in the direction of the launcher, D, motion,

Chapter 9 continued

$$v_{Df} = \frac{(0.0500 \text{ kg})(2.00 \text{ m/s}) + (4.65 \text{ kg})(2.00 \text{ m/s}) - (0.0500 \text{ kg})(647 \text{ m/s})}{4.65 \text{ kg}}$$

$$= -4.94 \text{ m/s, or } 4.94 \text{ m/s backwards}$$

Level 2

77. A 12.0-g rubber bullet travels at a velocity of 150 m/s, hits a stationary 8.5-kg concrete block resting on a frictionless surface, and ricochets in the opposite direction with a velocity of -1.0×10^2 m/s, as shown in **Figure 9-19**. How fast will the concrete block be moving?

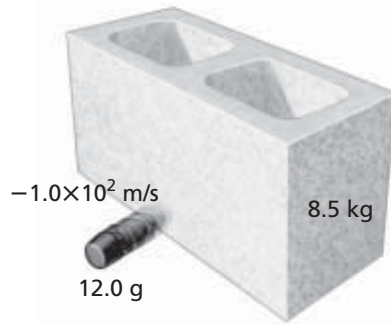

■ Figure 9-19

$$m_C v_{Ci} + m_D v_{Di} = m_C v_{Cf} + m_D v_{Df}$$

$$v_{Df} = \frac{m_C v_{Ci} + m_D v_{Di} - m_C v_{Cf}}{m_D}$$

since the block is initially at rest, this becomes

$$v_{Df} = \frac{m_C(v_{Ci} - v_{Cf})}{m_D}$$

$$= \frac{(0.0120 \text{ kg})(150 \text{ m/s} - (-1.0 \times 10^2 \text{ m/s}))}{8.5 \text{ kg}}$$

$$= 0.35 \text{ m/s}$$

78. **Skateboarding** Kofi, with mass 42.00 kg, is riding a skateboard with a mass of 2.00 kg and traveling at 1.20 m/s. Kofi jumps off and the skateboard stops dead in its tracks. In what direction and with what velocity did he jump?

$$(m_L v_{Li} + m_s v_{si})v_i = m_L v_{Lf} + m_s v_{sf}$$

where $v_{sf} = 0$ and $v_{Li} = v_{si} = v_i$

$$\text{Thus } v_{Lf} = \frac{(m_L + m_s)v_i}{m_L}$$

$$= \frac{(42.00 \text{ kg} + 2.00 \text{ kg})(1.20 \text{ m/s})}{42.00 \text{ kg}}$$

$$= 1.26 \text{ m/s in the same direction as she was riding}$$

79. **Billiards** A cue ball, with mass 0.16 kg, rolling at 4.0 m/s, hits a stationary eight ball of similar mass. If the cue ball travels 45° above its original path and the eight ball travels 45° below the horizontal, as shown in **Figure 9-20**, what is the velocity of each ball after the collision?

Chapter 9 continued

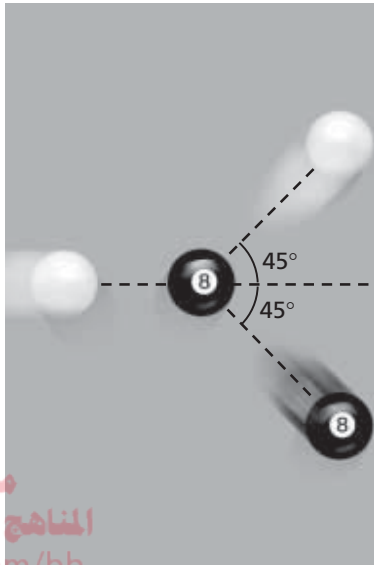

■ Figure 9-20

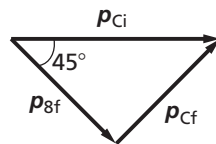

We can get momentum equations from the vector diagram.

$$p_{Cf} = p_{Ci} \sin 45^\circ$$

$$m_C v_{Cf} = m_C v_{Ci} \sin 45^\circ$$

$$\begin{aligned} v_{Cf} &= v_{Ci} \sin 45^\circ \\ &= (4.0 \text{ m/s})(\sin 45^\circ) \\ &= 2.8 \text{ m/s} \end{aligned}$$

For the eight ball,

$$p_{8f} = p_{Ci} \cos 45^\circ$$

$$m_8 v_{8f} = m_C v_{Ci} (\cos 45^\circ)$$

where $m_8 = m_C$. Thus,

$$\begin{aligned} v_{8f} &= v_{Ci} \cos 45^\circ \\ &= (4.0 \text{ m/s})(\cos 45^\circ) \\ &= 2.8 \text{ m/s} \end{aligned}$$

80. A 2575-kg van runs into the back of an 825-kg compact car at rest. They move off together at 8.5 m/s. Assuming that the friction with the road is negligible, calculate the initial speed of the van.

$$p_{Ci} + p_{Di} = p_{Cf} + p_{Df}$$

$$m_C v_{Ci} = (m_C + m_D) v_f$$

$$\text{so, } v_{Ci} = \frac{m_C + m_D}{m_C} v_f$$

$$\begin{aligned} v_f &= \frac{(2575 \text{ kg} + 825 \text{ kg})(8.5 \text{ m/s})}{2575 \text{ kg}} \\ &= 11 \text{ m/s} \end{aligned}$$

Level 3

81. **In-line Skating** Diego and Keshia are on in-line skates and stand face-to-face, then push each other away with their hands. Diego has a mass of 90.0 kg and Keshia has a mass of 60.0 kg.

- a. Sketch the event, identifying the "before" and "after" situations, and set up a coordinate axis.

Before: $m_K = 60.0 \text{ kg}$

$$m_D = 90.0 \text{ kg}$$

$$v_i = 0.0 \text{ m/s}$$

After: $m_K = 60.0 \text{ kg}$

$$m_D = 90.0 \text{ kg}$$

$$v_{Kf} = ?$$

$$v_{Df} = ?$$

Chapter 9 continued

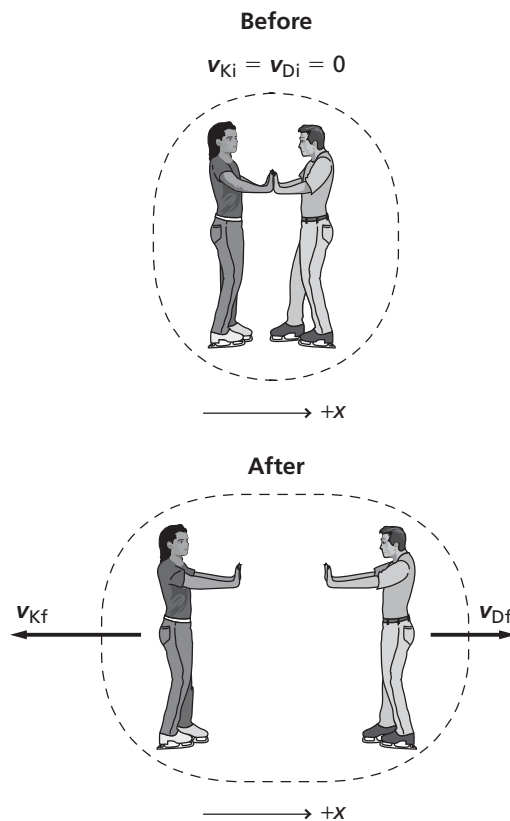

- b. Find the ratio of the skaters' velocities just after their hands lose contact.

$$p_{Ki} + p_{Di} = 0.0 \text{ kg}\cdot\text{m/s} = p_{Kf} + p_{Df}$$

$$\text{so, } m_K v_{Kf} + m_D v_{Df} = 0.0 \text{ kg}\cdot\text{m/s}$$

$$\text{and } m_K v_{Kf} = -m_D v_{Df}$$

Thus, the ratios of the velocities are

$$\frac{v_{Kf}}{v_{Df}} = -\left(\frac{m_D}{m_K}\right) = -\left(\frac{90.0 \text{ kg}}{60.0 \text{ kg}}\right) = -1.50$$

The negative sign shows that the velocities are in opposite directions.

- c. Which skater has the greater speed?

Keshia, who has the smaller mass, has the greater speed.

- d. Which skater pushed harder?

The forces were equal and opposite.

82. A 0.200-kg plastic ball moves with a velocity of 0.30 m/s. It collides with a second plastic ball of mass 0.100 kg, which is moving along the same line at a speed of 0.10 m/s. After the collision, both balls continue moving in the same, original direction. The speed of the 0.100-kg ball is 0.26 m/s. What is the new velocity of the 0.200-kg ball?

$$m_C v_{Ci} + m_D v_{Di} = m_C v_{Cf} + m_D v_{Df}$$

$$\text{so, } v_{Cf} = \frac{m_C v_{Ci} + m_D v_{Di} - m_D v_{Df}}{m_C}$$

Chapter 9 continued

$$\begin{aligned} &= \frac{(0.200 \text{ kg})(0.30 \text{ m/s}) + (0.100 \text{ kg})(0.10 \text{ m/s}) - (0.100 \text{ kg})(0.26 \text{ m/s})}{0.200 \text{ kg}} \\ &= 0.22 \text{ m/s in the original direction} \end{aligned}$$

Mixed Review

pages 253–254

Level 1

83. A constant force of 6.00 N acts on a 3.00-kg object for 10.0 s. What are the changes in the object's momentum and velocity?

The change in momentum is

$$\begin{aligned} \Delta p &= F\Delta t \\ &= (6.00 \text{ N})(10.0 \text{ s}) \\ &= 60.0 \text{ N}\cdot\text{s} = 60.0 \text{ kg}\cdot\text{m/s} \end{aligned}$$

The change in velocity is found from the impulse.

$$\begin{aligned} F\Delta t &= m\Delta v \\ \Delta v &= \frac{F\Delta t}{m} \\ &= \frac{(6.00 \text{ N})(10.0 \text{ s})}{3.00 \text{ kg}} \\ &= 20.0 \text{ m/s} \end{aligned}$$

84. The velocity of a 625-kg car is changed from 10.0 m/s to 44.0 m/s in 68.0 s by an external, constant force.
- a. What is the resulting change in momentum of the car?

$$\begin{aligned} \Delta p &= m\Delta v = m(v_f - v_i) \\ &= (625 \text{ kg})(44.0 \text{ m/s} - 10.0 \text{ m/s}) \\ &= 2.12 \times 10^4 \text{ kg}\cdot\text{m/s} \end{aligned}$$

- b. What is the magnitude of the force?

$$\begin{aligned} F\Delta t &= m\Delta v \\ \text{so, } F &= \frac{m\Delta v}{\Delta t} \\ &= \frac{m(v_f - v_i)}{\Delta t} \\ &= \frac{(625 \text{ kg})(44.0 \text{ m/s} - 10.0 \text{ m/s})}{68.0 \text{ s}} \\ &= 313 \text{ N} \end{aligned}$$

85. **Dragster** An 845-kg dragster accelerates on a race track from rest to 100.0 km/h in 0.90 s.

- a. What is the change in momentum of the dragster?

$$\begin{aligned} \Delta p &= m(v_f - v_i) \\ &= (845 \text{ kg})(100.0 \text{ km/h} - 0.0 \text{ km/h}) \left(\frac{1000 \text{ m}}{1 \text{ km}} \right) \left(\frac{1 \text{ h}}{3600 \text{ s}} \right) \\ &= 2.35 \times 10^4 \text{ kg}\cdot\text{m/s} \end{aligned}$$

Chapter 9 continued

- b. What is the average force exerted on the dragster?

$$F = \frac{m(v_f - v_i)}{\Delta t}$$

$$= \frac{(845 \text{ kg})(100.0 \text{ km/h} - 0.0 \text{ km/h})}{0.90 \text{ s}} \left(\frac{1000 \text{ m}}{1 \text{ km}} \right) \left(\frac{1 \text{ h}}{3600 \text{ s}} \right)$$

$$= 2.6 \times 10^4 \text{ N}$$

- c. What exerts that force?

The force is exerted by the track through friction.

Level 2

86. **Ice Hockey** A 0.115-kg hockey puck, moving at 35.0 m/s, strikes a 0.365-kg jacket that is thrown onto the ice by a fan of a certain hockey team. The puck and jacket slide off together. Find their velocity.

$$m_p v_{pi} = (m_p + m_j) v_f$$

$$v_f = \frac{m_p v_{pi}}{m_p + m_j}$$

$$= \frac{(0.115 \text{ kg})(35.0 \text{ m/s})}{(0.115 \text{ kg} + 0.365 \text{ kg})}$$

$$= 8.39 \text{ m/s}$$

87. A 50.0-kg woman, riding on a 10.0-kg cart, is moving east at 5.0 m/s. The woman jumps off the front of the cart and lands on the ground at 7.0 m/s eastward, relative to the ground.

- a. Sketch the "before" and "after" situations and assign a coordinate axis to them.

Before: $m_w = 50.0 \text{ kg}$

$m_c = 10.0 \text{ kg}$

$v_i = 5.0 \text{ m/s}$

After: $m_w = 50.0 \text{ kg}$

$m_c = 10.0 \text{ kg}$

$v_{wf} = 7.0 \text{ m/s}$

$v_{cf} = ?$

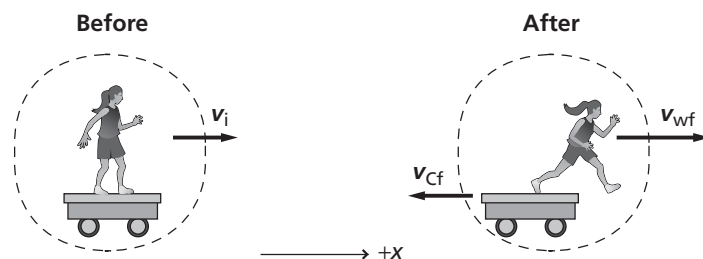

Chapter 9 continued

- b. Find the cart's velocity after the woman jumps off.

$$(m_w + m_c)v_i = m_w v_{wf} + m_c v_{cf}$$

$$\text{so, } v_{cf} = \frac{(m_w + m_c)v_i - m_w v_{wf}}{m_c}$$

$$= \frac{(50.0 \text{ kg} + 10.0 \text{ kg})(5.0 \text{ m/s}) - (50.0 \text{ kg})(7.0 \text{ m/s})}{10.0 \text{ kg}}$$

$$= -5.0 \text{ m/s, or } 5.0 \text{ m/s west}$$

88. **Gymnastics** Figure 9-21 shows a gymnast performing a routine. First, she does giant swings on the high bar, holding her body straight and pivoting around her hands. Then, she lets go of the high bar and grabs her knees with her hands in the tuck position. Finally, she straightens up and lands on her feet.

- a. In the second and final parts of the gymnast's routine, around what axis does she spin?

She spins around the center of mass of her body, first in the tuck position and then also as she straightens out.

- b. Rank in order, from greatest to least, her moments of inertia for the three positions.

giant swing (greatest), straight, tuck (least)

- c. Rank in order, from greatest to least, her angular velocities in the three positions.

tuck (greatest), straight, giant swing (least)



■ Figure 9-21

Level 3

89. A 60.0-kg male dancer leaps 0.32 m high.

- a. With what momentum does he reach the ground?

$$v = v_0^2 + 2dg$$

Thus, the velocity of the dancer is

$$v = \sqrt{2dg}$$

Chapter 9 continued

and his momentum is

$$\begin{aligned} p &= mv = m\sqrt{2dg} \\ &= (60.0 \text{ kg})\sqrt{(2)(0.32 \text{ m})(9.80 \text{ m/s}^2)} \\ &= 1.5 \times 10^2 \text{ kg}\cdot\text{m/s down} \end{aligned}$$

- b. What impulse is needed to stop the dancer?

$$F\Delta t = m\Delta v = m(v_f - v_i)$$

To stop the dancer, $v_f = 0$. Thus,

$$F\Delta t = -mv_f = -p = -1.5 \times 10^2 \text{ kg}\cdot\text{m/s up}$$

- c. As the dancer lands, his knees bend, lengthening the stopping time to 0.050 s. Find the average force exerted on the dancer's body.

$$\begin{aligned} F\Delta t &= m\Delta v = m\sqrt{2dg} \\ \text{so, } F &= \frac{m\sqrt{2dg}}{\Delta t} \\ &= \frac{(60.0 \text{ kg})\sqrt{(2)(0.32 \text{ m})(9.80 \text{ m/s}^2)}}{0.050 \text{ s}} \\ &= 3.0 \times 10^3 \text{ N} \end{aligned}$$

- d. Compare the stopping force with his weight.

$$F_g = mg = (60.0 \text{ kg})(9.80 \text{ m/s}^2) = 5.98 \times 10^2 \text{ N}$$

The force is about five times the weight.

Thinking Critically

page 254

90. **Apply Concepts** A 92-kg fullback, running at 5.0 m/s, attempts to dive directly across the goal line for a touchdown. Just as he reaches the line, he is met head-on in midair by two 75-kg linebackers, both moving in the direction opposite the fullback. One is moving at 2.0 m/s and the other at 4.0 m/s. They all become entangled as one mass.

- a. Sketch the event, identifying the "before" and "after" situations.

$$\text{Before: } m_A = 92 \text{ kg}$$

$$m_B = 75 \text{ kg}$$

$$m_C = 75 \text{ kg}$$

$$v_{Ai} = 5.0 \text{ m/s}$$

$$v_{Bi} = -2.0 \text{ m/s}$$

$$v_{Ci} = -4.0 \text{ m/s}$$

$$\text{After: } m_A = 92 \text{ kg}$$

$$m_B = 75 \text{ kg}$$

$$m_C = 75 \text{ kg}$$

$$v_f = ?$$

Chapter 9 continued

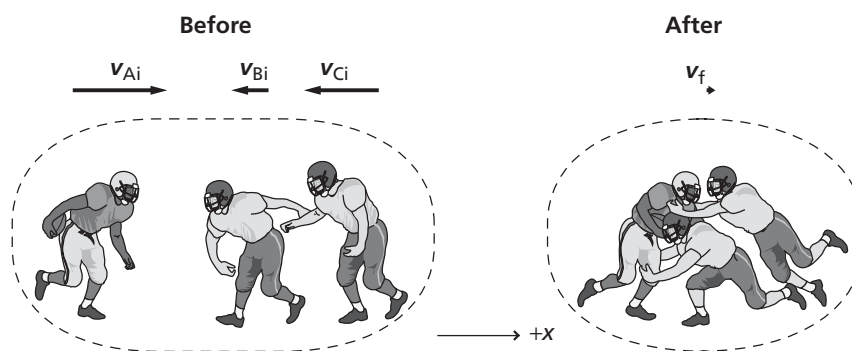

- b. What is the velocity of the football players after the collision?

$$p_{Ai} + p_{Bi} + p_{Ci} = p_{Af} + p_{Bf} + p_{Cf}$$

$$m_A v_{Ai} + m_B v_{Bi} + m_C v_{Ci} = m_A v_{Af} + m_B v_{Bf} + m_C v_{Cf}$$

$$= (m_A + m_B + m_C) v_f$$

$$v_f = \frac{m_A v_{Ai} + m_B v_{Bi} + m_C v_{Ci}}{m_A + m_B + m_C}$$

$$= \frac{(92 \text{ kg})(5.0 \text{ m/s}) + (75 \text{ kg})(-2.0 \text{ m/s}) + (75 \text{ kg})(-4.0 \text{ m/s})}{92 \text{ kg} + 75 \text{ kg} + 75 \text{ kg}}$$

$$= 0.041 \text{ m/s}$$

- c. Does the fullback score a touchdown?

Yes. The velocity is positive, so the football crosses the goal line for a touchdown.

91. **Analyze and Conclude** A student, holding a bicycle wheel with its axis vertical, sits on a stool that can rotate without friction. She uses her hand to get the wheel spinning. Would you expect the student and stool to turn? If so, in which direction? Explain.

The student and the stool would spin slowly in the direction opposite to that of the wheel. Without friction there are no external torques. Thus, the angular momentum of the system is not changed. The angular momentum of the student and stool must be equal and opposite to the angular momentum of the spinning wheel.

92. **Analyze and Conclude** Two balls during a collision are shown in **Figure 9-22**, which is drawn to scale. The balls enter from the left, collide, and then bounce away. The heavier ball, at the bottom of the diagram, has a mass of 0.600 kg, and the other has a mass of 0.400 kg. Using a vector diagram, determine whether momentum is conserved in this collision. Explain any difference in the momentum of the system before and after the collision.

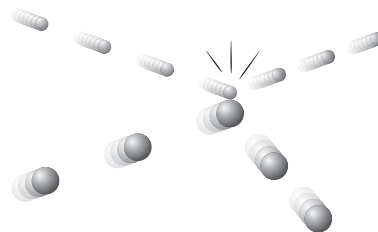

■ Figure 9-22

Dotted lines show that the changes of momentum for each ball are equal and opposite: $\Delta(m_A v_A) = \Delta(m_B v_B)$. Because the masses have a 3:2 ratio, a 2:3 ratio of velocity changes will compensate.

Chapter 9 continued

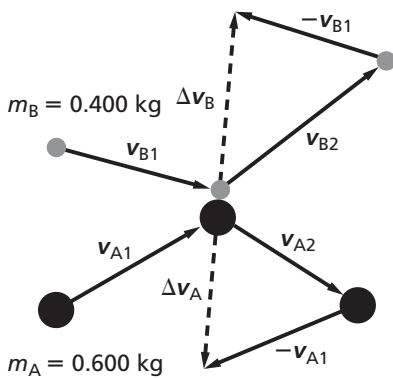

Writing in Physics

page 254

93. How can highway barriers be designed to be more effective in saving people's lives? Research this issue and describe how impulse and change in momentum can be used to analyze barrier designs.

The change in a car's momentum does not depend on how it is brought to a stop. Thus, the impulse also does not change. To reduce the force, the time over which a car is stopped must be increased. Using barriers that can extend the time it takes to stop a car will reduce the force. Flexible, plastic containers filled with sand often are used.

94. While air bags save many lives, they also have caused injuries and even death. Research the arguments and responses of automobile makers to this statement. Determine whether the problems involve impulse and momentum or other issues.

There are two ways an air bag reduces injury. First, an air bag extends the time over which the impulse acts, thereby reducing the force. Second, an air bag spreads the force over a larger area, thereby reducing the pressure. Thus, the injuries due to forces from small objects are reduced. The dangers of air bags mostly center on the fact that air bags must be inflated very rapidly. The surface of an air bag can approach the passenger at speeds of up to 322 km/h (200 mph). Injuries can occur when the moving bag collides with the person.

Systems are being developed that will adjust the rate at which gases fill the air bags to match the size of the person.

Cumulative Review

page 254

95. A 0.72-kg ball is swung vertically from a 0.60-m string in uniform circular motion at a speed of 3.3 m/s. What is the tension in the cord at the top of the ball's motion? (Chapter 6)

The tension is the gravitational force minus the centripetal force.

$$\begin{aligned}
 F_T &= F_g - F_c \\
 &= mg - \frac{mv^2}{r} = m\left(g - \frac{v^2}{r}\right) \\
 &= (0.72 \text{ kg})\left(9.80 \text{ m/s}^2 - \frac{(3.3 \text{ m/s})^2}{0.60 \text{ m}}\right) \\
 &= -6.0 \text{ N}
 \end{aligned}$$

96. You wish to launch a satellite that will remain above the same spot on Earth's surface. This means the satellite must have a period of exactly one day. Calculate the radius of the circular orbit this satellite must have. *Hint: The Moon also circles Earth and both the Moon and the satellite will obey Kepler's third law. The Moon is $3.9 \times 10^8 \text{ m}$ from Earth and its period is 27.33 days.* (Chapter 7)

$$\begin{aligned}
 \left(\frac{T_s}{T_m}\right)^2 &= \left(\frac{r_s}{r_m}\right)^3 \\
 \text{so } r_s &= \left(\left(\frac{T_s}{T_m}\right)^2 r_m\right)^{\frac{1}{3}} \\
 &= \left(\left(\frac{1.000 \text{ day}}{27.33 \text{ days}}\right)^2 (3.9 \times 10^8 \text{ m})^3\right)^{\frac{1}{3}} \\
 &= 4.3 \times 10^7 \text{ m}
 \end{aligned}$$

97. A rope is wrapped around a drum that is 0.600 m in diameter. A machine pulls with a constant 40.0 N force for a total of 2.00 s. In that time, 5.00 m of rope is unwound. Find α , ω at 2.00 s, and I . (Chapter 8)

The angular acceleration is the ratio of the linear acceleration of the drum's edge and drum's radius.

Chapter 9 continued

$$\alpha = \frac{a}{r}$$

The linear acceleration is found from the equation of motion.

$$x = \frac{1}{2}at^2$$

$$a = \frac{2x}{t^2}$$

Thus, the angular acceleration is

$$\begin{aligned}\alpha &= \frac{a}{r} = \frac{2x}{rt^2} \\ &= \frac{(2)(5.00 \text{ m})}{\left(\frac{0.600 \text{ m}}{2}\right)(2.00 \text{ s})^2} \\ &= 8.33 \text{ rad/s}^2\end{aligned}$$

At the end of 2.00 s, the angular velocity is

$$\begin{aligned}\omega &= \alpha t \\ &= \frac{2xt}{rt^2} \\ &= \frac{2x}{rt} \\ &= \frac{(2)(5.00 \text{ m})}{\left(\frac{0.600 \text{ m}}{2}\right)(2.00 \text{ s})} \\ &= 16.7 \text{ rad/s}\end{aligned}$$

The moment of inertia is

$$\begin{aligned}I &= \frac{\tau}{\alpha} \\ &= \frac{Fr \sin \theta}{\left(\frac{2x}{rt^2}\right)} = \frac{Fr^2t^2 \sin \theta}{2x} \\ &= \frac{(40.0 \text{ N})\left(\frac{0.600 \text{ m}}{2}\right)^2(2.00 \text{ s})^2(\sin 90.0^\circ)}{(2)(5.00 \text{ m})} \\ &= 1.44 \text{ kg}\cdot\text{m}^2\end{aligned}$$

Challenge Problem

page 244

Your friend was driving her 1265-kg car north on Oak Street when she was hit by a 925-kg compact car going west on Maple Street. The cars stuck together and slid 23.1 m at 42° north of west. The speed limit on both streets is 22 m/s (50 mph). Assume that momentum was conserved during the collision and that acceleration was constant during the skid. The coefficient of kinetic friction between the tires and the pavement is 0.65.

Chapter 9 continued

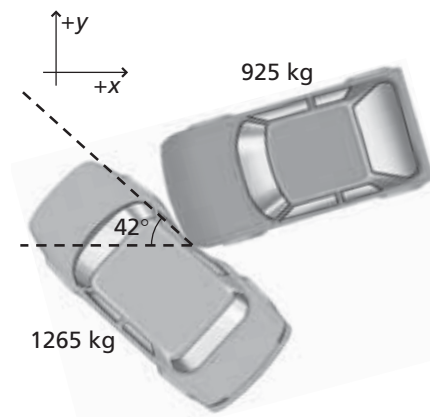

1. Your friend claims that she wasn't speeding, but that the driver of other car was. How fast was your friend driving before the crash?

The vector diagram provides a momentum equation for the friend's car.

$$p_{Ci} = p_f \sin 42^\circ$$

The friend's initial velocity, then, is

$$v_{Ci} = \frac{p_{Ci}}{m_C} = \frac{(m_C + m_D)v_f \sin 42^\circ}{m_C}$$

We can find v_f first by finding the acceleration and time of the skid. The acceleration is

$$a = \frac{F}{m} = \frac{\mu F_g}{m} = \frac{\mu(m_C + m_D)g}{m_C + m_D} = \mu g$$

The time can be derived from the distance equation.

$$d = \frac{1}{2}at^2$$

$$t = \sqrt{\frac{2d}{a}} = \sqrt{\frac{2d}{\mu g}}$$

The final velocity, then, is

$$v_f = at = \mu g \sqrt{\frac{2d}{\mu g}} = \sqrt{2d\mu g}$$

Using this, we now can find the friend's initial velocity.

$$\begin{aligned} v_{Ci} &= \frac{(m_C + m_D)v_f \sin 42^\circ}{m_C} \\ &= \frac{(m_C + m_D)\sqrt{2d\mu g} \sin 42^\circ}{m_C} \\ &= \frac{(1265 \text{ kg} + 925 \text{ kg})\left(\sqrt{(2)(23.1 \text{ m})(0.65)(9.80 \text{ m/s}^2)}\right)(\sin 42^\circ)}{1265 \text{ kg}} \\ &= 2.0 \times 10^1 \text{ m/s} \end{aligned}$$

Chapter 9 continued

2. How fast was the other car moving before the crash? Can you support your friend's case in court?

From the vector diagram, the momentum equation for the other car is

$$\begin{aligned} p_{Di} &= p_f \cos 42^\circ \\ &= (m_C + m_D)v_f \cos 42^\circ \\ &= (m_C + m_D)\sqrt{2d\mu g} (\cos 42^\circ) \end{aligned}$$

The other car's initial velocity, then, is,

$$\begin{aligned} v_{Di} &= \frac{p_{Di}}{m_D} \\ &= \frac{(m_C + m_D)\sqrt{2d\mu g} (\sin 42^\circ)}{m_D} \end{aligned}$$

موقع
البحرينية
almanahj.com/bh

$$\begin{aligned} &= \frac{(1265 \text{ kg} + 925 \text{ kg})\left(\sqrt{(2)(23.1 \text{ m})(0.65)(9.80 \text{ m/s}^2)}\right)(\cos 42^\circ)}{925 \text{ kg}} \\ &= 3.0 \times 10^1 \text{ m/s} \end{aligned}$$

The friend was not exceeding the 22 m/s speed limit. The other car was exceeding the speed limit.

Practice Problems

10.1 Energy and Work pages 257–265

page 261

1. Refer to Example Problem 1 to solve the following problem.

- a. If the hockey player exerted twice as much force, 9.00 N, on the puck, how would the puck's change in kinetic energy be affected?

Because $W = Fd$ and $\Delta KE = W$, doubling the force would double the work, which would double the change in kinetic energy to 1.35 J.

- b. If the player exerted a 9.00 N-force, but the stick was in contact with the puck for only half the distance, 0.075 m, what would be the change in kinetic energy?

Because $W = Fd$, halving the distance would cut the work in half, which also would cut the change in kinetic energy in half, to 0.68 J.

2. Together, two students exert a force of 825 N in pushing a car a distance of 35 m.

- a. How much work do the students do on the car?

$$W = Fd = (825 \text{ N})(35 \text{ m}) \\ = 2.9 \times 10^4 \text{ J}$$

- b. If the force was doubled, how much work would they do pushing the car the same distance?

$$W = Fd \\ = (2)(825 \text{ N})(35 \text{ m}) \\ = 5.8 \times 10^4 \text{ J which is twice as much work}$$

3. A rock climber wears a 7.5-kg backpack while scaling a cliff. After 30.0 min, the climber is 8.2 m above the starting point.

- a. How much work does the climber do on the backpack?

$$W = Fd \\ = mgd \\ = (7.5 \text{ kg})(9.80 \text{ m/s}^2)(8.2 \text{ m}) \\ = 6.0 \times 10^2 \text{ J}$$

- b. If the climber weighs 645 N, how much work does she do lifting herself and the backpack?

$$W = Fd + 6.0 \times 10^2 \text{ J} \\ = (645 \text{ N})(8.2 \text{ m}) + 6.0 \times 10^2 \text{ J} \\ = 5.9 \times 10^3 \text{ J}$$

- c. What is the average power developed by the climber?

$$P = \frac{W}{t} = \left(\frac{5.9 \times 10^3 \text{ J}}{30.0 \text{ min}} \right) \left(\frac{1 \text{ min}}{60 \text{ s}} \right) \\ = 3.3 \text{ W}$$

page 262

4. If the sailor in Example Problem 2 pulled with the same force, and along the same distance, but at an angle of 50.0° , how much work would he do?

$$W = Fd \cos \theta \\ = (255 \text{ N})(30.0 \text{ m})(\cos 50.0^\circ) \\ = 4.92 \times 10^3 \text{ J}$$

5. Two people lift a heavy box a distance of 15 m. They use ropes, each of which makes an angle of 15° with the vertical. Each person exerts a force of 225 N. How much work do they do?

$$W = Fd \cos \theta \\ = (2)(225 \text{ N})(15 \text{ m})(\cos 15^\circ) \\ = 6.5 \times 10^3 \text{ J}$$

Chapter 10 continued

6. An airplane passenger carries a 215-N suitcase up the stairs, a displacement of 4.20 m vertically, and 4.60 m horizontally.

a. How much work does the passenger do?

Since gravity acts vertically, only the vertical displacement needs to be considered.

$$W = Fd = (215 \text{ N})(4.20 \text{ m}) = 903 \text{ J}$$

b. The same passenger carries the same suitcase back down the same set of stairs. How much work does the passenger do now?

Force is upward, but vertical displacement is downward, so

$$\begin{aligned} W &= Fd \cos \theta \\ &= (215 \text{ N})(4.20 \text{ m})(\cos 180.0^\circ) \\ &= -903 \text{ J} \end{aligned}$$

7. A rope is used to pull a metal box a distance of 15.0 m across the floor. The rope is held at an angle of 46.0° with the floor, and a force of 628 N is applied to the rope. How much work does the force on the rope do?

$$\begin{aligned} W &= Fd \cos \theta \\ &= (628 \text{ N})(15.0 \text{ m})(\cos 46.0^\circ) \\ &= 6.54 \times 10^3 \text{ J} \end{aligned}$$

8. A bicycle rider pushes a bicycle that has a mass of 13 kg up a steep hill. The incline is 25° and the road is 275 m long, as shown in **Figure 10-4**. The rider pushes the bike parallel to the road with a force of 25 N.

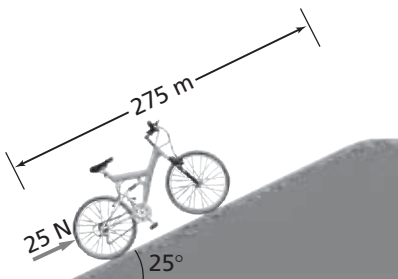

■ **Figure 10-4** (Not to scale)

a. How much work does the rider do on the bike?

Force and displacement are in the same direction.

$$\begin{aligned} W &= Fd \\ &= (25 \text{ N})(275 \text{ m}) \\ &= 6.9 \times 10^3 \text{ J} \end{aligned}$$

b. How much work is done by the force of gravity on the bike?

The force is downward (-90°), and the displacement is 25° above the horizontal or 115° from the force.

$$\begin{aligned} W &= Fd \cos \theta \\ &= mgd \cos \theta \\ &= (13 \text{ kg})(9.80 \text{ m/s}^2)(275 \text{ m}) \\ &\quad (\cos 115^\circ) \\ &= -1.5 \times 10^4 \text{ J} \end{aligned}$$

page 264

9. A box that weighs 575 N is lifted a distance of 20.0 m straight up by a cable attached to a motor. The job is done in 10.0 s. What power is developed by the motor in W and kW?

$$\begin{aligned} P &= \frac{W}{t} = \frac{Fd}{t} = \frac{(575 \text{ N})(20.0 \text{ m})}{10.0 \text{ s}} \\ &= 1.15 \times 10^3 \text{ W} = 1.15 \text{ kW} \end{aligned}$$

10. You push a wheelbarrow a distance of 60.0 m at a constant speed for 25.0 s, by exerting a 145-N force horizontally.

a. What power do you develop?

$$P = \frac{W}{t} = \frac{Fd}{t} = \frac{(145 \text{ N})(60.0 \text{ m})}{25.0 \text{ s}} = 348 \text{ W}$$

b. If you move the wheelbarrow twice as fast, how much power is developed?

t is halved, so P is doubled to 696 W.

11. What power does a pump develop to lift 35 L of water per minute from a depth of 110 m? (1 L of water has a mass of 1.00 kg.)

$$P = \frac{W}{t} = \frac{mgd}{t} = \left(\frac{m}{t}\right)gd$$

$$\text{where } \frac{m}{t} = (35 \text{ L/min})(1.00 \text{ kg/L})$$

Thus,

$$\begin{aligned} P &= \left(\frac{m}{t}\right)gd \\ &= (35 \text{ L/min})(1.00 \text{ kg/L})(9.80 \text{ m/s}^2) \\ &\quad (110 \text{ m})(1 \text{ min}/60\text{s}) \\ &= 0.63 \text{ kW} \end{aligned}$$

Chapter 10 continued

12. An electric motor develops 65 kW of power as it lifts a loaded elevator 17.5 m in 35 s. How much force does the motor exert?

$$P = \frac{W}{t} = \frac{Fd}{t}$$

$$F = \frac{Pt}{d} = \frac{(65 \times 10^3 \text{ W})(35 \text{ s})}{17.5 \text{ m}}$$

$$= 1.3 \times 10^5 \text{ N}$$

13. A winch designed to be mounted on a truck, as shown in **Figure 10-7**, is advertised as being able to exert a 6.8×10^3 -N force and to develop a power of 0.30 kW. How long would it take the truck and the winch to pull an object 15 m?



■ Figure 10-7

$$P = \frac{W}{t} = \frac{Fd}{t}$$

$$t = \frac{Fd}{P}$$

$$= \frac{(6.8 \times 10^3 \text{ N})(15 \text{ m})}{(0.30 \times 10^3 \text{ W})} = 340 \text{ s}$$

$$= 5.7 \text{ min}$$

14. Your car has stalled and you need to push it. You notice as the car gets going that you need less and less force to keep it going. Suppose that for the first 15 m, your force decreased at a constant rate from 210.0 N to 40.0 N. How much work did you do on the car? Draw a force-displacement graph to represent the work done during this period.

The work done is the area of the trapezoid under the solid line:

$$W = \frac{1}{2}d(F_1 + F_2)$$

$$= \frac{1}{2}(15 \text{ m})(210.0 \text{ N} + 40.0 \text{ N})$$

$$= 1.9 \times 10^3 \text{ J}$$

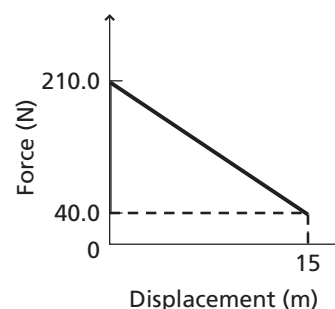

Section Review

10.1 Energy and Work pages 257–265

page 265

15. **Work** Murimi pushes a 20-kg mass 10 m across a floor with a horizontal force of 80 N. Calculate the amount of work done by Murimi.

$$W = Fd = (80 \text{ N})(10 \text{ m}) = 8 \times 10^2 \text{ J}$$

The mass is not important to this problem.

16. **Work** A mover loads a 185-kg refrigerator into a moving van by pushing it up a 10.0-m, friction-free ramp at an angle of inclination of 11.0° . How much work is done by the mover?

$$y = (10.0 \text{ m})(\sin 11.0^\circ)$$

$$= 1.91 \text{ m}$$

$$W = Fd = mgd \sin \theta$$

$$= (185 \text{ kg})(9.80 \text{ m/s}^2)(10.0 \text{ m})(\sin 11.0^\circ)$$

$$= 3.46 \times 10^3 \text{ J}$$

17. **Work and Power** Does the work required to lift a book to a high shelf depend on how fast you raise it? Does the power required to lift the book depend on how fast you raise it? Explain.

No, work is not a function of time.

However, power is a function of time, so the power required to lift the book does depend on how fast you raise it.

Chapter 10 continued

- 18. Power** An elevator lifts a total mass of 1.1×10^3 kg a distance of 40.0 m in 12.5 s. How much power does the elevator generate?

$$P = \frac{W}{t} = \frac{Fd}{t} = \frac{mgd}{t}$$

$$= \frac{(1.1 \times 10^3 \text{ kg})(9.80 \text{ m/s}^2)(40.0 \text{ m})}{12.5 \text{ s}}$$

$$= 3.4 \times 10^4 \text{ W}$$

- 19. Work** A 0.180-kg ball falls 2.5 m. How much work does the force of gravity do on the ball?

$$W = F_g d = mgd$$

$$= (0.180 \text{ kg})(9.80 \text{ m/s}^2)(2.5 \text{ m})$$

$$= 4.4 \text{ J}$$

- 20. Mass** A forklift raises a box 1.2 m and does 7.0 kJ of work on it. What is the mass of the box?

$$W = Fd = mgd$$

$$\text{so } m = \frac{W}{gd} = \frac{7.0 \times 10^3 \text{ J}}{(9.80 \text{ m/s}^2)(1.2 \text{ m})}$$

$$= 6.0 \times 10^2 \text{ kg}$$

- 21. Work** You and a friend each carry identical boxes from the first floor of a building to a room located on the second floor, farther down the hall. You choose to carry the box first up the stairs, and then down the hall to the room. Your friend carries it down the hall on the first floor, then up a different stairwell to the second floor. Who does more work?

Both do the same amount of work. Only the height lifted and the vertical force exerted count.

- 22. Work and Kinetic Energy** If the work done on an object doubles its kinetic energy, does it double its velocity? If not, by what ratio does it change the velocity?

Kinetic energy is proportional to the square of the velocity, so doubling the energy doubles the square of the velocity. The velocity increases by a factor of the square root of 2, or 1.4.

- 23. Critical Thinking** Explain how to find the change in energy of a system if three agents exert forces on the system at once.

Since work is the change in kinetic energy, calculate the work done by each force. The work can be positive, negative, or zero, depending on the relative angles of the force and displacement of the object. The sum of the three works is the change in energy of the system.

Practice Problems

10.2 Machines pages 266–273

page 272

- 24.** If the gear radius in the bicycle in Example Problem 4 is doubled, while the force exerted on the chain and the distance the wheel rim moves remain the same, what quantities change, and by how much?

$$IMA = \frac{r_e}{r_r} = \frac{8.00 \text{ cm}}{35.6 \text{ cm}} = 0.225 \text{ (doubled)}$$

$$MA = \left(\frac{e}{100}\right)IMA = \frac{95.0}{100}(0.225)$$

$$= 0.214 \text{ (doubled)}$$

$$MA = \frac{F_r}{F_e} \text{ so } F_r = (MA)(F_e)$$

$$= (0.214)(155 \text{ N})$$

$$= 33.2 \text{ N}$$

$$IMA = \frac{d_e}{d_r}$$

$$\text{so } d_e = (IMA)(d_r)$$

$$= (0.225)(14.0 \text{ cm})$$

$$= 3.15 \text{ cm}$$

- 25.** A sledgehammer is used to drive a wedge into a log to split it. When the wedge is driven 0.20 m into the log, the log is separated a distance of 5.0 cm. A force of 1.7×10^4 N is needed to split the log, and the sledgehammer exerts a force of 1.1×10^4 N.

- a. What is the *IMA* of the wedge?

$$IMA = \frac{d_e}{d_r} = \frac{(0.20 \text{ m})}{(0.050 \text{ m})} = 4.0$$

Chapter 10 continued

- b. What is the *MA* of the wedge?

$$MA = \frac{F_r}{F_e} = \frac{(1.7 \times 10^4 \text{ N})}{(1.1 \times 10^4 \text{ N})} = 1.5$$

- c. Calculate the efficiency of the wedge as a machine.

$$e = \frac{MA}{IMA} \times 100 = \frac{1.5}{4.0} \times 100 = 38\%$$

26. A worker uses a pulley system to raise a 24.0-kg carton 16.5 m, as shown in **Figure 10-14**. A force of 129 N is exerted, and the rope is pulled 33.0 m.

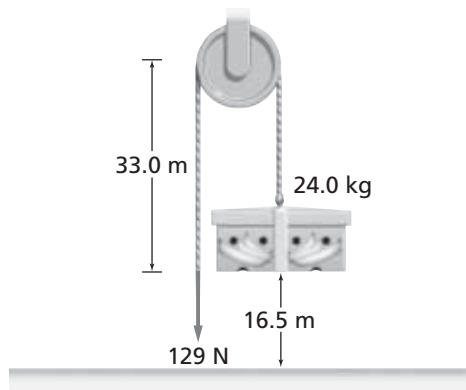

■ **Figure 10-14**

- a. What is the *MA* of the pulley system?

$$MA = \frac{F_r}{F_e} = \frac{mg}{F_e} = \frac{(24.0 \text{ kg})(9.80 \text{ m/s}^2)}{129 \text{ N}} = 1.82$$

- b. What is the efficiency of the system?

$$\begin{aligned} \text{efficiency} &= \left(\frac{MA}{IMA} \right) \times 100 \\ &= \frac{(MA)(100)}{\frac{d_e}{d_r}} \\ &= \frac{(MA)(d_r)(100)}{d_e} \\ &= \frac{(1.82)(16.5 \text{ m})(100)}{33.0 \text{ m}} \\ &= 91.0\% \end{aligned}$$

27. You exert a force of 225 N on a lever to raise a 1.25×10^3 -N rock a distance of 13 cm. If the efficiency of the lever is 88.7 percent, how far did you move your end of the lever?

$$\begin{aligned} \text{efficiency} &= \frac{W_o}{W_i} \times 100 \\ &= \frac{F_r d_r}{F_e d_e} \times 100 \end{aligned}$$

$$\begin{aligned} \text{So } d_e &= \frac{F_r d_r (100)}{F_e (\text{efficiency})} \\ &= \frac{(1.25 \times 10^3 \text{ N})(0.13 \text{ m})(100)}{(225 \text{ N})(88.7)} \\ &= 0.81 \text{ m} \end{aligned}$$

28. A winch has a crank with a 45-cm radius. A rope is wrapped around a drum with a 7.5-cm radius. One revolution of the crank turns the drum one revolution.

- a. What is the ideal mechanical advantage of this machine?

Compare effort and resistance distances for 1 rev:

$$IMA = \frac{d_e}{d_r} = \frac{(2\pi)45 \text{ cm}}{(2\pi)7.5 \text{ cm}} = 6.0$$

- b. If, due to friction, the machine is only 75 percent efficient, how much force would have to be exerted on the handle of the crank to exert 750 N of force on the rope?

$$\begin{aligned} \text{efficiency} &= \left(\frac{MA}{IMA} \right) \times 100 \\ &= \frac{F_r}{(F_e)(IMA)} \times 100 \\ \text{so } F_e &= \frac{(F_r)(100)}{(\text{efficiency})(IMA)} \\ &= \frac{(750 \text{ N})(100)}{(75)(6.0)} \\ &= 1.7 \times 10^2 \text{ N} \end{aligned}$$

Section Review

10.2 Machines
pages 266–273

page 273

29. **Simple Machines** Classify the tools below as a lever, a wheel and axle, an inclined plane, a wedge, or a pulley.

a. screwdriver

wheel and axle

b. pliers

lever

c. chisel

wedge

d. nail puller

lever

30. **IMA** A worker is testing a multiple pulley system to estimate the heaviest object that he could lift. The largest downward force he could exert is equal to his weight, 875 N. When the worker moves the rope 1.5 m, the object moves 0.25 m. What is the heaviest object that he could lift?

$$MA = \frac{F_r}{F_e}$$

$$\text{so } F_r = (MA)(F_e)$$

Assuming the efficiency is 100%,

$$\begin{aligned} MA = IMA &= \left(\frac{d_e}{d_r}\right)(F_e) \\ &= \frac{(1.5 \text{ m})}{(0.25 \text{ m})}(875 \text{ N}) \\ &= 5.2 \times 10^3 \text{ N} \end{aligned}$$

31. **Compound Machines** A winch has a crank on a 45-cm arm that turns a drum with a 7.5-cm radius through a set of gears. It takes three revolutions of the crank to rotate the drum through one revolution. What is the *IMA* of this compound machine?

The *IMA* of the system is the product of the *IMA* of each machine. For the crank and drum, the ratio of distances is

$$\frac{2\pi(45 \text{ cm})}{2\pi(7.5 \text{ cm})} = 6.0.$$

$$\begin{aligned} IMA &= \frac{d_e}{d_r} = \frac{(3)(2\pi r)}{2\pi r} \\ &= \frac{(3)(2\pi)(45 \text{ cm})}{(2\pi)(7.5 \text{ cm})} \\ &= 18 \end{aligned}$$

32. **Efficiency** Suppose you increase the efficiency of a simple machine. Do the *MA* and *IMA* increase, decrease, or remain the same?

Either *MA* increases while *IMA* remains the same, or *IMA* decreases while *MA* remains the same, or *MA* increases while *IMA* decreases.

33. **Critical Thinking** The mechanical advantage of a multi-gear bicycle is changed by moving the chain to a suitable rear gear.

a. To start out, you must accelerate the bicycle, so you want to have the bicycle exert the greatest possible force. Should you choose a small or large gear?

$$\text{large, to increase } IMA = \frac{r_{\text{gear}}}{r_{\text{wheel}}}$$

b. As you reach your traveling speed, you want to rotate the pedals as few times as possible. Should you choose a small or large gear?

Small, because less chain travel, hence few pedal revolutions, will be required per wheel revolution.

c. Many bicycles also let you choose the size of the front gear. If you want even more force to accelerate while climbing a hill, would you move to a larger or smaller front gear?

smaller, to increase pedal-front gear *IMA* because

$$IMA = \frac{r_{\text{pedal}}}{r_{\text{front gear}}}$$

Chapter Assessment

Concept Mapping

page 278

34. Create a concept map using the following terms: *force, displacement, direction of motion, work, change in kinetic energy.*

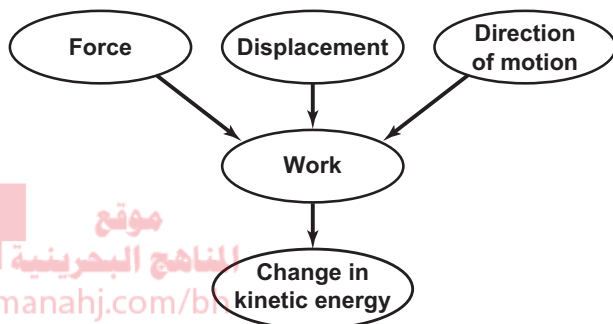

Mastering Concepts

page 278

35. In what units is work measured? (10.1)
joules
36. Suppose a satellite revolves around Earth in a circular orbit. Does Earth's gravity do any work on the satellite? (10.1)
No, the force of gravity is directed toward Earth and is perpendicular to the direction of displacement of the satellite.
37. An object slides at constant speed on a frictionless surface. What forces act on the object? What work is done by each force? (10.1)
Only gravity and an upward, normal force act on the object. No work is done because the displacement is perpendicular to these forces. There is no force in the direction of displacement because the object is sliding at a constant speed.
38. Define *work* and *power*. (10.1)
Work is the product of force and the distance over which an object is moved in the direction of the force. Power is the time rate at which work is done.

39. What is a watt equivalent to in terms of kilograms, meters, and seconds? (10.1)

$$\begin{aligned}
 W &= \text{J/s} \\
 &= \text{N}\cdot\text{m/s} \\
 &= (\text{kg}\cdot\text{m/s}^2)\cdot\text{m/s} \\
 &= \text{kg}\cdot\text{m}^2/\text{s}^3
 \end{aligned}$$

40. Is it possible to get more work out of a machine than you put into it? (10.2)
no, $e \leq 100\%$
41. Explain how the pedals of a bicycle are a simple machine. (10.2)
Pedals transfer force from the rider to the bike through a wheel and axle.

Applying Concepts

page 278

42. Which requires more work, carrying a 420-N backpack up a 200-m-high hill or carrying a 210-N backpack up a 400-m-high hill? Why?
Each requires the same amount of work because force times distance is the same.
43. **Lifting** You slowly lift a box of books from the floor and put it on a table. Earth's gravity exerts a force, magnitude mg , downward, and you exert a force, magnitude mg , upward. The two forces have equal magnitudes and opposite directions. It appears that no work is done, but you know that you did work. Explain what work was done.
You do positive work on the box because the force and motion are in the same direction. Gravity does negative work on the box because the force of gravity is opposite to the direction of motion. The work done by you and by gravity are separate and do not cancel each other.
44. You have an after-school job carrying cartons of new copy paper up a flight of stairs, and then carrying recycled paper back down the stairs. The mass of the paper does not

Chapter 10 continued

change. Your physics teacher says that you do not work all day, so you should not be paid. In what sense is the physics teacher correct? What arrangement of payments might you make to ensure that you are properly compensated?

The net work is zero. Carrying the carton upstairs requires positive work; carrying it back down is negative work. The work done in both cases is equal and opposite because the distances are equal and opposite. The student might arrange the payments on the basis of the time it takes to carry paper, whether up or down, not on the basis of work done.

45. You carry the cartons of copy paper down the stairs, and then along a 15-m-long hallway. Are you working now? Explain.
No, the force on the box is up and the displacement is down the hall. They are perpendicular and no work is done.
46. **Climbing Stairs** Two people of the same mass climb the same flight of stairs. The first person climbs the stairs in 25 s; the second person does so in 35 s.
- Which person does more work? Explain your answer.
Both people are doing the same amount of work because they both are climbing the same flight of stairs and they have the same mass.
 - Which person produces more power? Explain your answer.
The person who climbs in 25 s expends more power, as less time is needed to cover the distance.

47. Show that power delivered can be written as $P = Fv \cos \theta$.

$$P = \frac{W}{t}, \text{ but } W = Fd \cos \theta$$

$$\text{so, } P = \frac{Fd \cos \theta}{t}$$

$$\text{because } v = \frac{d}{t},$$

$$P = Fv \cos \theta$$

48. How can you increase the ideal mechanical advantage of a machine?

Increase the ratio of d_e/d_r to increase the IMA of a machine.

49. **Wedge** How can you increase the mechanical advantage of a wedge without changing its ideal mechanical advantage?

Reduce friction as much as possible to reduce the resistance force.

50. **Orbits** Explain why a planet orbiting the Sun does not violate the work-energy theorem.

Assuming a circular orbit, the force due to gravity is perpendicular to the direction of motion. This means the work done is zero. Hence, there is no change in kinetic energy of the planet, so it does not speed up or slow down. This is true for a circular orbit.

51. **Claw Hammer** A claw hammer is used to pull a nail from a piece of wood, as shown in **Figure 10-16**. Where should you place your hand on the handle and where should the nail be located in the claw to make the effort force as small as possible?



■ **Figure 10-16**

Your hand should be as far from the head as possible to make d_e as large as possible. The nail should be as close to the head as possible to make d_r as small as possible.

Chapter 10 continued

Mastering Problems

10.1 Energy and Work

pages 278–280

Level 1

52. The third floor of a house is 8 m above street level. How much work is needed to move a 150-kg refrigerator to the third floor?

$$\begin{aligned} W &= Fd = mgd \\ &= (150 \text{ kg})(9.80 \text{ m/s}^2)(8 \text{ m}) \\ &= 1 \times 10^4 \text{ J} \end{aligned}$$

53. Haloke does 176 J of work lifting himself 0.300 m. What is Haloke's mass?

$$\begin{aligned} W &= Fd = mgd; \text{ therefore,} \\ m &= \frac{W}{gd} = \frac{176 \text{ J}}{(9.80 \text{ m/s}^2)(0.300 \text{ m})} \\ &= 59.9 \text{ kg} \end{aligned}$$

54. **Football** After scoring a touchdown, an 84.0-kg wide receiver celebrates by leaping 1.20 m off the ground. How much work was done by the wide receiver in the celebration?

$$\begin{aligned} W &= Fd = mgd \\ &= (84.0 \text{ kg})(9.80 \text{ m/s}^2)(1.20 \text{ m}) \\ &= 988 \text{ J} \end{aligned}$$

55. **Tug-of-War** During a tug-of-war, team A does 2.20×10^5 J of work in pulling team B 8.00 m. What force was team A exerting?

$$\begin{aligned} W &= Fd, \text{ so} \\ F &= \frac{W}{d} = \frac{2.20 \times 10^5 \text{ J}}{8.00 \text{ m}} = 2.75 \times 10^4 \text{ N} \end{aligned}$$

56. To keep a car traveling at a constant velocity, a 551-N force is needed to balance frictional forces. How much work is done against friction by the car as it travels from Columbus to Cincinnati, a distance of 161 km?

$$\begin{aligned} W &= Fd = (551 \text{ N})(1.61 \times 10^5 \text{ m}) \\ &= 8.87 \times 10^7 \text{ J} \end{aligned}$$

57. **Cycling** A cyclist exerts a force of 15.0 N as he rides a bike 251 m in 30.0 s. How much power does the cyclist develop?

$$\begin{aligned} P &= \frac{W}{t} = \frac{Fd}{t} \\ &= \frac{(15.0 \text{ N})(251 \text{ m})}{30.0 \text{ s}} \\ &= 126 \text{ W} \end{aligned}$$

58. A student librarian lifts a 2.2-kg book from the floor to a height of 1.25 m. He carries the book 8.0 m to the stacks and places the book on a shelf that is 0.35 m above the floor. How much work does he do on the book?

Only the net vertical displacement counts.

$$\begin{aligned} W &= Fd = mgd \\ &= (2.2 \text{ kg})(9.80 \text{ m/s}^2)(0.35 \text{ m}) \\ &= 7.5 \text{ J} \end{aligned}$$

59. A force of 300.0 N is used to push a 145-kg mass 30.0 m horizontally in 3.00 s.

- a. Calculate the work done on the mass.

$$\begin{aligned} W &= Fd = (300.0 \text{ N})(30.0 \text{ m}) \\ &= 9.00 \times 10^3 \text{ J} \\ &= 9.00 \text{ kJ} \end{aligned}$$

- b. Calculate the power developed.

$$\begin{aligned} P &= \frac{W}{t} = \frac{9.00 \times 10^3 \text{ J}}{3.00 \text{ s}} \\ &= 3.00 \times 10^3 \text{ W} \\ &= 3.00 \text{ kW} \end{aligned}$$

Level 2

60. **Wagon** A wagon is pulled by a force of 38.0 N exerted on the handle at an angle of 42.0° with the horizontal. If the wagon is pulled in a circle of radius 25.0 m, how much work is done?

$$\begin{aligned} W &= Fd \cos \theta \\ &= (F)(2\pi r) \cos \theta \\ &= (38.0 \text{ N})(2\pi)(25.0 \text{ m})(\cos 42.0^\circ) \\ &= 4.44 \times 10^3 \text{ J} \end{aligned}$$

61. **Lawn Mower** Shani is pushing a lawn mower with a force of 88.0 N along a handle that makes an angle of 41.0° with the horizontal. How much work is done by

Chapter 10 continued

Shani in moving the lawn mower 1.2 km to mow the yard?

$$\begin{aligned} W &= Fd \cos \theta \\ &= (88.0 \text{ N})(1.2 \times 10^3 \text{ m})(\cos 41.0^\circ) \\ &= 8.0 \times 10^4 \text{ J} \end{aligned}$$

62. A 17.0-kg crate is to be pulled a distance of 20.0 m, requiring 1210 J of work to be done. If the job is done by attaching a rope and pulling with a force of 75.0 N, at what angle is the rope held?

$$\begin{aligned} W &= Fd \cos \theta \\ \theta &= \cos^{-1} \left(\frac{W}{Fd} \right) \\ &= \cos^{-1} \left(\frac{1210 \text{ J}}{(75.0 \text{ N})(20.0 \text{ m})} \right) \\ &= 36.2^\circ \end{aligned}$$

63. **Lawn Tractor** A 120-kg lawn tractor, shown in **Figure 10-17**, goes up a 21° incline that is 12.0 m long in 2.5 s. Calculate the power that is developed by the tractor.

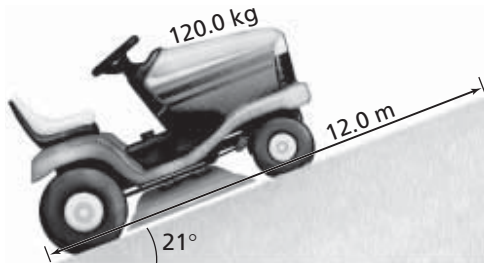

■ Figure 10-17

$$\begin{aligned} P &= \frac{W}{t} = \frac{Fd \sin \theta}{t} = \frac{mgd \sin \theta}{t} \\ &= \frac{(120 \text{ kg})(9.80 \text{ m/s}^2)(12.0 \text{ m})(\sin 21^\circ)}{2.5 \text{ s}} \\ &= 2.0 \times 10^3 \text{ W} = 2.0 \text{ kW} \end{aligned}$$

64. You slide a crate up a ramp at an angle of 30.0° by exerting a 225-N force parallel to the ramp. The crate moves at a constant speed. The coefficient of friction is 0.28. How much work did you do on the crate as it was raised a vertical distance of 1.15 m?

F and d are parallel so

$$W = Fd = F \left(\frac{h}{\sin \theta} \right)$$

$$\begin{aligned} &= \frac{(225 \text{ N})(1.15 \text{ m})}{\sin 30.0^\circ} \\ &= 518 \text{ J} \end{aligned}$$

65. **Piano** A 4.2×10^3 -N piano is to be slid up a 3.5-m frictionless plank at a constant speed. The plank makes an angle of 30.0° with the horizontal. Calculate the work done by the person sliding the piano up the plank.

The force parallel to the plane is given by

$$\begin{aligned} F_{\parallel} &= F \sin \theta \\ \text{so } W &= F_{\parallel} d = Fd \sin \theta \\ W &= (4200 \text{ N})(3.5 \text{ m})(\sin 30.0^\circ) \\ &= 7.4 \times 10^3 \text{ J} \end{aligned}$$

66. **Sled** Diego pulls a 4.5-kg sled across level snow with a force of 225 N on a rope that is 35.0° above the horizontal, as shown in **Figure 10-18**. If the sled moves a distance of 65.3 m, how much work does Diego do?

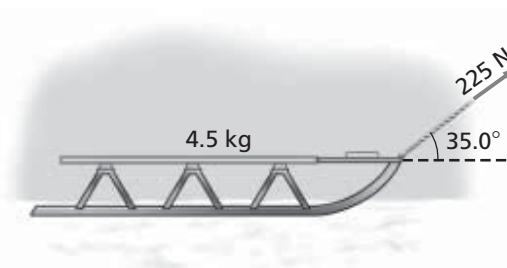

■ Figure 10-18

$$\begin{aligned} W &= Fd \cos \theta \\ &= (225 \text{ N})(65.3 \text{ m})(\cos 35.0^\circ) \\ &= 1.20 \times 10^4 \text{ J} \end{aligned}$$

67. **Escalator** Sau-Lan has a mass of 52 kg. She rides up the escalator at Ocean Park in Hong Kong. This is the world's longest escalator, with a length of 227 m and an average inclination of 31°. How much work does the escalator do on Sau-Lan?

$$\begin{aligned} W &= Fd \sin \theta = mgd \sin \theta \\ &= (52 \text{ kg})(9.80 \text{ m/s}^2)(227 \text{ m})(\sin 31^\circ) \\ &= 6.0 \times 10^4 \text{ J} \end{aligned}$$

68. **Lawn Roller** A lawn roller is pushed across a lawn by a force of 115 N along the direction of the handle, which is 22.5°

Chapter 10 continued

above the horizontal. If 64.6 W of power is developed for 90.0 s, what distance is the roller pushed?

$$P = \frac{W}{t} = \frac{Fd \cos \theta}{t} \text{ so,}$$

$$d = \frac{Pt}{F \cos \theta}$$

$$= \frac{(64.6 \text{ W})(90.0 \text{ s})}{(115 \text{ N})(\cos 22.5^\circ)}$$

$$= 54.7 \text{ m}$$

69. John pushes a crate across the floor of a factory with a horizontal force. The roughness of the floor changes, and John must exert a force of 20 N for 5 m, then 35 N for 12 m, and then 10 N for 8 m.

- a. Draw a graph of force as a function of distance.

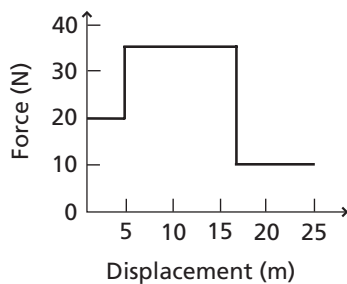

- b. Find the work John does pushing the crate.

$$W = F_1d_1 + F_2d_2 + F_3d_3$$

$$= (20 \text{ N})(5 \text{ m}) + (35 \text{ N})(12 \text{ m}) + (10 \text{ N})(8 \text{ m})$$

$$= 600 \text{ J}$$

70. Maricruz slides a 60.0-kg crate up an inclined ramp that is 2.0-m long and attached to a platform 1.0 m above floor level, as shown in **Figure 10-19**. A 400.0-N force, parallel to the ramp, is needed to slide the crate up the ramp at a constant speed.

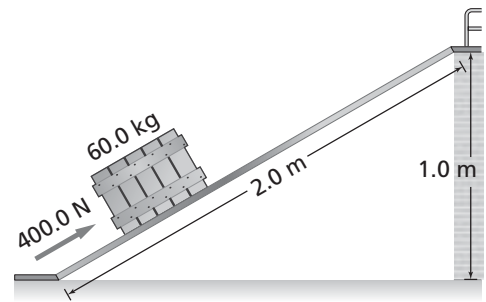

■ **Figure 10-19**

- a. How much work does Maricruz do in sliding the crate up the ramp?
 $W = Fd = (400.0 \text{ N})(2.0 \text{ m}) = 8.0 \times 10^2 \text{ J}$
- b. How much work would be done if Maricruz simply lifted the crate straight up from the floor to the platform?

$$W = Fd = mgd$$

$$= (60.0 \text{ kg})(9.80 \text{ m/s}^2)(1.0 \text{ m})$$

$$= 5.9 \times 10^2 \text{ J}$$

71. **Boat Engine** An engine moves a boat through the water at a constant speed of 15 m/s. The engine must exert a force of 6.0 kN to balance the force that the water exerts against the hull. What power does the engine develop?

$$P = \frac{W}{t} = \frac{Fd}{t} = Fv$$

$$= (6.0 \times 10^3 \text{ N})(15 \text{ m/s})$$

$$= 9.0 \times 10^4 \text{ W} = 9.0 \times 10^1 \text{ kW}$$

Level 3

72. In **Figure 10-20**, the magnitude of the force necessary to stretch a spring is plotted against the distance the spring is stretched.

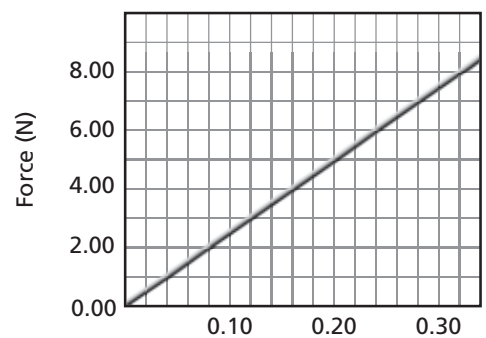

■ **Figure 10-20**

Chapter 10 continued

- a. Calculate the slope of the graph, k , and show that $F = kd$, where $k = 25 \text{ N/m}$.

$$k = \frac{\Delta y}{\Delta x} = \frac{5.00 \text{ N} - 0.00 \text{ N}}{0.20 \text{ m} - 0.00 \text{ m}}$$

$$F_1 = kd_1$$

$$\text{Let } d_1 = 0.20 \text{ m}$$

From the graph, F_1 is 5.00 N.

$$\begin{aligned} \text{So } k &= \frac{F_1}{d_1} \\ &= \frac{5.00 \text{ N}}{0.20 \text{ m}} = 25 \text{ N/m} \end{aligned}$$

- b. Find the amount of work done in stretching the spring from 0.00 m to 0.20 m by calculating the area under the graph from 0.00 m to 0.20 m.

$$\begin{aligned} A &= \frac{1}{2}(\text{base})(\text{height}) \\ &= \left(\frac{1}{2}\right)(0.20 \text{ m})(5.00 \text{ N}) \\ &= 0.50 \text{ J} \end{aligned}$$

- c. Show that the answer to part b can be calculated using the formula $W = \frac{1}{2}kd^2$, where W is the work, $k = 25 \text{ N/m}$ (the slope of the graph), and d is the distance the spring is stretched (0.20 m).

$$\begin{aligned} W &= \frac{1}{2}kd^2 = \left(\frac{1}{2}\right)(25 \text{ N/m})(0.20 \text{ m})^2 \\ &= 0.50 \text{ J} \end{aligned}$$

73. Use the graph in Figure 10-20 to find the work needed to stretch the spring from 0.12 m to 0.28 m.

Add the areas of the triangle and rectangle. The area of the triangle is:

$$\begin{aligned} \frac{1}{2}bh &= \frac{1}{2}(0.28 \text{ m} - 0.12 \text{ m})(7.00 \text{ N} - 3.00 \text{ N}) \\ &= 0.32 \text{ J} \end{aligned}$$

The area of the rectangle is:

$$\begin{aligned} bh &= (0.28 \text{ m} - 0.12 \text{ m})(3.00 \text{ N} - 0.00 \text{ N}) \\ &= 0.48 \text{ J} \end{aligned}$$

Total work is $0.32 \text{ J} + 0.48 \text{ J} = 0.80 \text{ J}$

74. A worker pushes a crate weighing 93 N up an inclined plane. The worker pushes the crate horizontally, parallel to the ground, as illustrated in Figure 10-21.

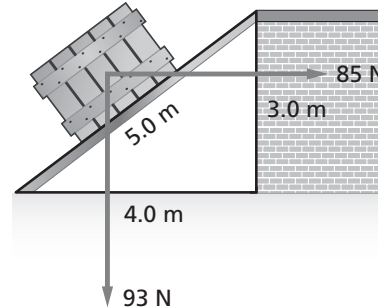

■ Figure 10-21

- a. The worker exerts a force of 85 N. How much work does he do?

Displacement in direction of force is 4.0 m,

$$\begin{aligned} \text{so } W &= Fd = (85 \text{ N})(4.0 \text{ m}) \\ &= 3.4 \times 10^2 \text{ J} \end{aligned}$$

- b. How much work is done by gravity? (Be careful with the signs you use.)

Displacement in direction of force is -3.0 m ,

$$\begin{aligned} \text{so } W &= Fd = (93 \text{ N})(-3.0 \text{ m}) \\ &= -2.8 \times 10^2 \text{ J} \end{aligned}$$

- c. The coefficient of friction is $\mu = 0.20$. How much work is done by friction? (Be careful with the signs you use.)

$$\begin{aligned} W &= \mu F_N d = \mu(F_{\text{you}, \perp} + F_{g, \perp})d \\ &= 0.20(85 \text{ N})(\sin \theta) + \\ &\quad (93 \text{ N})(\cos \theta)(-5.0 \text{ m}) \\ &= 0.20(85 \text{ N})\left(\frac{3.0}{5.0}\right) + \\ &\quad (93 \text{ N})\left(\frac{4.0}{5.0}\right)(-5.0 \text{ m}) \\ &= -1.3 \times 10^2 \text{ J (work done against friction)} \end{aligned}$$

75. **Oil Pump** In 35.0 s, a pump delivers 0.550 m^3 of oil into barrels on a platform 25.0 m above the intake pipe. The oil's density is 0.820 g/cm^3 .

Chapter 10 continued

- a. Calculate the work done by the pump.

The work done is

$$\begin{aligned} W &= F_g d = mgh \\ &= (\text{volume})(\text{density})gh \\ &= (0.550 \text{ m}^3)(0.820 \text{ g/cm}^3) \left(\frac{1 \text{ kg}}{1000 \text{ g}} \right) \\ &\quad (1.00 \times 10^6 \text{ cm}^3/\text{m}^3)(9.80 \text{ m/s}^2) \\ &\quad (25.0 \text{ m}) \\ &= 1.10 \times 10^5 \text{ J} \end{aligned}$$

- b. Calculate the power produced by the pump.

$$\begin{aligned} P &= \frac{W}{t} = \frac{1.10 \times 10^5 \text{ J}}{35.0 \text{ s}} \\ &= 3.14 \times 10^3 \text{ W} = 3.14 \text{ kW} \end{aligned}$$

- 76. Conveyor Belt** A 12.0-m-long conveyor belt, inclined at 30.0° , is used to transport bundles of newspapers from the mail room up to the cargo bay to be loaded onto delivery trucks. Each newspaper has a mass of 1.0 kg, and there are 25 newspapers per bundle. Determine the power that the conveyor develops if it delivers 15 bundles per minute.

$$\begin{aligned} P &= \frac{W}{t} = \frac{Fd}{t} = \frac{mgd}{t} \\ &= (25 \text{ newspapers})(15 \text{ bundles/min}) \\ &\quad (1.0 \text{ kg/newspaper})(9.80 \text{ m/s}^2) \\ &\quad (12.0 \text{ m})(\sin 30.0^\circ)(1 \text{ min}/60 \text{ s}) \\ &= 3.7 \times 10^2 \text{ W} \end{aligned}$$

- 77.** A car is driven at a constant speed of 76 km/h down a road. The car's engine delivers 48 kW of power. Calculate the average force that is resisting the motion of the car.

$$\begin{aligned} P &= \frac{W}{t} = \frac{Fd}{t} = Fv \\ \text{so } F &= \frac{P}{v} \\ &= \frac{48,000 \text{ W}}{\left(\frac{76 \text{ km}}{1 \text{ h}} \right) \left(\frac{1000 \text{ m}}{1 \text{ km}} \right) \left(\frac{1 \text{ h}}{3600 \text{ s}} \right)} \\ &= 2.3 \times 10^3 \text{ N} \end{aligned}$$

- 78.** The graph in **Figure 10-22** shows the force and displacement of an object being pulled.

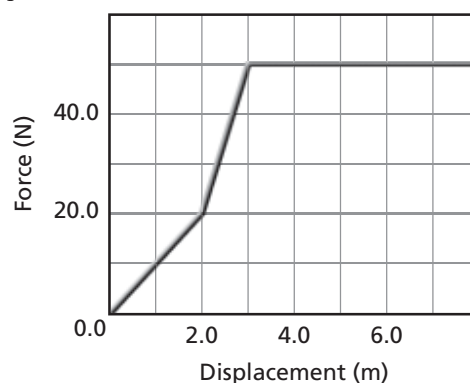

■ Figure 10-22

- a. Calculate the work done to pull the object 7.0 m.

Find the area under the curve (see graph):

0.0 to 2.0 m:

$$\frac{1}{2}(20.0 \text{ N})(2.0 \text{ m}) = 2.0 \times 10^1 \text{ J}$$

2.0 m to 3.0 m:

$$\frac{1}{2}(30.0 \text{ N})(1.0 \text{ m}) + (20 \text{ N})(1.0 \text{ m}) = 35 \text{ J}$$

3.0 m to 7.0 m:

$$(50.0 \text{ N})(4.0 \text{ m}) = 2.0 \times 10^2 \text{ J}$$

Total work:

$$\begin{aligned} &2.0 \times 10^1 \text{ J} + 35 \text{ J} + 2.0 \times 10^2 \text{ J} \\ &= 2.6 \times 10^2 \text{ J} \end{aligned}$$

- b. Calculate the power that would be developed if the work was done in 2.0 s.

$$P = \frac{W}{t} = \frac{2.6 \times 10^2 \text{ J}}{2.0 \text{ s}} = 1.3 \times 10^2 \text{ W}$$

Chapter 10 continued

10.2 Machines

pages 280–281

Level 1

79. Piano Takeshi raises a 1200-N piano a distance of 5.00 m using a set of pulleys. He pulls in 20.0 m of rope.

- a. How much effort force would Takeshi apply if this were an ideal machine?

$$\frac{F_r}{F_e} = \frac{d_e}{d_r}$$

$$\text{so } F_e = \frac{F_r d_r}{d_e} = \frac{(1200 \text{ N})(5.00 \text{ m})}{20.0 \text{ m}} = 3.0 \times 10^2 \text{ N}$$

- b. What force is used to balance the friction force if the actual effort is 340 N?

$$F_e = F_f + F_{e, \text{ ideal}}$$

$$F_f = F_e - F_{e, \text{ ideal}} = 340 \text{ N} - 3.0 \times 10^2 \text{ N} = 40 \text{ N}$$

- c. What is the output work?

$$W_o = F_r d_r = (1200 \text{ N})(5.00 \text{ m}) = 6.0 \times 10^3 \text{ J}$$

- d. What is the input work?

$$W_i = F_e d_e = (340 \text{ N})(20.0 \text{ m}) = 6.8 \times 10^3 \text{ J}$$

- e. What is the mechanical advantage?

$$MA = \frac{F_r}{F_e} = \frac{1200 \text{ N}}{340 \text{ N}} = 3.5$$

80. Lever Because there is very little friction, the lever is an extremely efficient simple machine. Using a 90.0-percent-efficient lever, what input work is required to lift an 18.0-kg mass through a distance of 0.50 m?

$$\text{efficiency} = \frac{W_o}{W_i} \times 100$$

$$W_i = \frac{(W_o)(100)}{\text{efficiency}} = \frac{(mgd)(100)}{90.0} = \frac{(18.0 \text{ kg})(9.80 \text{ m/s}^2)(0.50 \text{ m})(100)}{90.0} = 98 \text{ J}$$

81. A pulley system lifts a 1345-N weight a distance of 0.975 m. Paul pulls the rope a distance of 3.90 m, exerting a force of 375 N.

- a. What is the ideal mechanical advantage of the system?

$$IMA = \frac{d_e}{d_r} = \frac{3.90 \text{ m}}{0.975 \text{ m}} = 4.00$$

- b. What is the mechanical advantage?

$$MA = \frac{F_r}{F_e} = \frac{1345 \text{ N}}{375 \text{ N}} = 3.59$$

- c. How efficient is the system?

$$\begin{aligned} \text{efficiency} &= \frac{MA}{IMA} \times 100 \\ &= \frac{3.59}{4.00} \times 100 \\ &= 89.8\% \end{aligned}$$

82. A force of 1.4 N is exerted through a distance of 40.0 cm on a rope in a pulley system to lift a 0.50-kg mass 10.0 cm. Calculate the following.

- a. the MA

$$\begin{aligned} MA &= \frac{F_r}{F_e} = \frac{mg}{F_e} \\ &= \frac{(0.50 \text{ kg})(9.80 \text{ m/s}^2)}{1.4 \text{ N}} \\ &= 3.5 \end{aligned}$$

- b. the IMA

$$IMA = \frac{d_e}{d_r} = \frac{40.0 \text{ cm}}{10.0 \text{ cm}} = 4.00$$

- c. the efficiency

$$\begin{aligned} \text{efficiency} &= \frac{MA}{IMA} \times 100 \\ &= \frac{3.5}{4.00} \times 100 = 88\% \end{aligned}$$

83. A student exerts a force of 250 N on a lever, through a distance of 1.6 m, as he lifts a 150-kg crate. If the efficiency of the lever is 90.0 percent, how far is the crate lifted?

$$\begin{aligned} e = 90 &= \frac{MA}{IMA} \times 100 = \frac{\frac{F_r}{F_e}}{\frac{d_e}{d_r}} \times 100 \\ &= \frac{F_r d_r}{F_e d_e} \times 100 \end{aligned}$$

Chapter 10 continued

$$\begin{aligned} \text{so, } d_r &= \frac{eF_e d_e}{100F_r} = \frac{eF_e d_e}{100mg} \\ &= \frac{(90.0)(250 \text{ N})(1.6 \text{ m})}{(100)(150 \text{ kg})(9.80 \text{ m/s}^2)} \\ &= 0.24 \text{ m} \end{aligned}$$

Level 2

84. What work is required to lift a 215-kg mass a distance of 5.65 m, using a machine that is 72.5 percent efficient?

$$\begin{aligned} e &= \frac{W_o}{W_i} \times 100 \\ &= \frac{F_r d_r}{W_i} \times 100 \\ &= \frac{mgd_r}{W_i} \times 100 \end{aligned}$$

$$\begin{aligned} W_i &= \frac{mgd_r}{e} \times 100 \\ &= \frac{(215 \text{ kg})(9.80 \text{ m/s}^2)(5.65 \text{ m})(100)}{72.5} \\ &= 1.64 \times 10^4 \text{ J} \end{aligned}$$

85. The ramp in **Figure 10-23** is 18 m long and 4.5 m high.

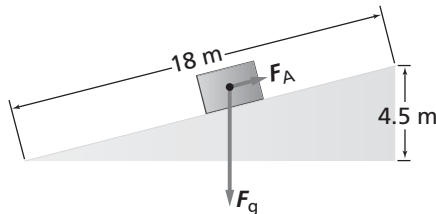

■ **Figure 10-23**

- a. What force, parallel to the ramp (F_A), is required to slide a 25-kg box at constant speed to the top of the ramp if friction is disregarded?

$$W = F_g d = mgh$$

$$\begin{aligned} \text{so } F &= F_g = \frac{mgh}{d} \\ &= \frac{(25 \text{ kg})(9.80 \text{ m/s}^2)(4.5 \text{ m})}{18 \text{ m}} \\ &= 61 \text{ N} \end{aligned}$$

- b. What is the *IMA* of the ramp?

$$IMA = \frac{d_e}{d_f} = \frac{18 \text{ m}}{4.5 \text{ m}} = 4.0$$

- c. What are the real *MA* and the efficiency of the ramp if a parallel force of 75 N is actually required?

$$\begin{aligned} MA &= \frac{F_r}{F_e} \\ &= \left(\frac{mg}{F_e} \right) \frac{(25 \text{ kg})(9.80 \text{ m/s}^2)}{75 \text{ N}} = 3.3 \end{aligned}$$

$$\begin{aligned} \text{efficiency} &= \frac{MA}{IMA} \times 100 \\ &= \frac{3.3}{4.0} \times 100 = 82\% \end{aligned}$$

86. **Bicycle** Luisa pedals a bicycle with a gear radius of 5.00 cm and a wheel radius of 38.6 cm, as shown in **Figure 10-24**. If the wheel revolves once, what is the length of the chain that was used?



■ **Figure 10-24**

$$d = 2\pi r = 2\pi(5.00 \text{ cm}) = 31.4 \text{ cm}$$

Level 3

87. **Crane** A motor with an efficiency of 88 percent operates a crane with an efficiency of 42 percent. If the power supplied to the motor is 5.5 kW, with what constant speed does the crane lift a 410-kg crate of machine parts?

$$\text{Total efficiency} = (88\%)(42\%) = 37\%$$

$$\begin{aligned} \text{Useful Power} &= (5.5 \text{ kW})(37\%) \\ &= 2.0 \text{ kW} \\ &= 2.0 \times 10^3 \text{ W} \end{aligned}$$

Chapter 10 continued

$$P = \frac{W}{t} = \frac{Fd}{t} = F\left(\frac{d}{t}\right) = Fv$$

$$v = \frac{P}{F_g} = \frac{P}{mg} = \frac{2.0 \times 10^3 \text{ W}}{(410 \text{ kg})(9.80 \text{ m/s}^2)}$$

$$= 0.50 \text{ m/s}$$

88. A compound machine is constructed by attaching a lever to a pulley system. Consider an ideal compound machine consisting of a lever with an IMA of 3.0 and a pulley system with an IMA of 2.0.

- a. Show that the IMA of this compound machine is 6.0.

$$W_{i1} = W_{o1} = W_{i2} = W_{o2}$$

$$W_{i1} = W_{o2}$$

$$F_{e1}d_{e1} = F_{r2}d_{r2}$$

For the compound machine

$$IMA_c = \frac{d_{e1}}{d_{r2}}$$

$$\frac{d_{e1}}{d_{r1}} = IMA_1 \text{ and } \frac{d_{e2}}{d_{r2}} = IMA_2$$

$$d_{r1} = d_{e2}$$

$$\frac{d_{e1}}{IMA_1} = d_{r1} = d_{e2} = (IMA_2)(d_{r2})$$

$$d_{e1} = (IMA_1)(IMA_2)(d_{r2})$$

$$\frac{d_{e1}}{d_{r2}} = IMA_c = (IMA_1)(IMA_2)$$

$$= (3.0)(2.0) = 6.0$$

- b. If the compound machine is 60.0 percent efficient, how much effort must be applied to the lever to lift a 540-N box?

$$e = \frac{MA}{IMA} \times 100 = \frac{\frac{F_r}{F_e}}{IMA} \times 100$$

$$= \frac{(F_r)(100)}{(F_e)(IMA)}$$

$$\text{so } F_e = \frac{(F_r)(100)}{(e)(IMA)}$$

$$= \frac{(540 \text{ N})(100)}{(60.0)(6.0)} = 150 \text{ N}$$

- c. If you move the effort side of the lever 12.0 cm, how far is the box lifted?

$$\frac{d_{e1}}{d_{r2}} = IMA_c$$

$$d_{r2} = \frac{d_{e1}}{IMA_c} = \frac{12.0 \text{ cm}}{6.0} = 2.0 \text{ cm}$$

Mixed Review

pages 281–282

Level 1

89. **Ramps** Isra has to get a piano onto a 2.0-m-high platform. She can use a 3.0-m-long frictionless ramp or a 4.0-m-long frictionless ramp. Which ramp should Isra use if she wants to do the least amount of work?

Either ramp: only the vertical distance is important. If Isra used a longer ramp, she would require less force. The work done would be the same.

90. Brutus, a champion weightlifter, raises 240 kg of weights a distance of 2.35 m.

- a. How much work is done by Brutus lifting the weights?

$$W = Fd = mgd$$

$$= (240 \text{ kg})(9.80 \text{ m/s}^2)(2.35 \text{ m})$$

$$= 5.5 \times 10^3 \text{ J}$$

- b. How much work is done by Brutus holding the weights above his head?

$$d = 0, \text{ so no work}$$

- c. How much work is done by Brutus lowering them back to the ground?

d is opposite of motion in part a, so W is also the opposite, $-5.5 \times 10^3 \text{ J}$.

- d. Does Brutus do work if he lets go of the weights and they fall back to the ground?

No. He exerts no force, so he does no work, positive or negative.

- e. If Brutus completes the lift in 2.5 s, how much power is developed?

$$P = \frac{W}{t} = \frac{5.5 \times 10^3 \text{ J}}{2.5 \text{ s}} = 2.2 \text{ kW}$$

Chapter 10 continued

Level 2

91. A horizontal force of 805 N is needed to drag a crate across a horizontal floor with a constant speed. You drag the crate using a rope held at an angle of 32° .

- a. What force do you exert on the rope?

$$F_x = F \cos \theta$$

$$\begin{aligned} \text{so } F &= \frac{F_x}{\cos \theta} = \frac{805 \text{ N}}{\cos 32^\circ} \\ &= 9.5 \times 10^2 \text{ N} \end{aligned}$$

- b. How much work do you do on the crate if you move it 22 m?

$$\begin{aligned} W &= F_x d = (805 \text{ N})(22 \text{ m}) \\ &= 1.8 \times 10^4 \text{ J} \end{aligned}$$

- c. If you complete the job in 8.0 s, what power is developed?

$$P = \frac{W}{t} = \frac{1.8 \times 10^4 \text{ J}}{8.0 \text{ s}} = 2.2 \text{ kW}$$

92. **Dolly and Ramp** A mover's dolly is used to transport a refrigerator up a ramp into a house. The refrigerator has a mass of 115 kg. The ramp is 2.10 m long and rises 0.850 m. The mover pulls the dolly with a force of 496 N up the ramp. The dolly and ramp constitute a machine.

- a. What work does the mover do?

$$\begin{aligned} W_i &= Fd = (496 \text{ N})(2.10 \text{ m}) \\ &= 1.04 \times 10^3 \text{ J} \end{aligned}$$

- b. What is the work done on the refrigerator by the machine?

$$\begin{aligned} d &= \text{height raised} = 0.850 \text{ m} \\ W_o &= F_g d = mgd \\ &= (115 \text{ kg})(9.80 \text{ m/s}^2)(0.850 \text{ m}) \\ &= 958 \text{ J} \end{aligned}$$

- c. What is the efficiency of the machine?

$$\begin{aligned} \text{efficiency} &= \frac{W_o}{W_i} \times 100 \\ &= \frac{958 \text{ J}}{1.04 \times 10^3 \text{ J}} \times 100 \\ &= 92.1\% \end{aligned}$$

93. Sally does 11.4 kJ of work dragging a wooden crate 25.0 m across a floor at a constant speed. The rope makes an angle of 48.0° with the horizontal.

- a. How much force does the rope exert on the crate?

$$W = Fd \cos \theta$$

$$\begin{aligned} \text{so } F &= \frac{W}{d \cos \theta} = \frac{11,400 \text{ J}}{(25.0 \text{ m})(\cos 48.0^\circ)} \\ &= 681 \text{ N} \end{aligned}$$

- b. What is the force of friction acting on the crate?

The crate moves with constant speed, so the force of friction equals the horizontal component of the force of the rope.

$$\begin{aligned} F_f &= F_x = F \cos \theta \\ &= (681 \text{ N})(\cos 48.0^\circ) \\ &= 456 \text{ N, opposite to the direction of motion} \end{aligned}$$

- c. What work is done by the floor through the force of friction between the floor and the crate?

Force and displacement are in opposite directions, so

$$\begin{aligned} W &= -Fd = -(456 \text{ N})(25.0 \text{ m}) \\ &= -1.14 \times 10^4 \text{ J} \end{aligned}$$

(Because no net forces act on the crate, the work done on the crate must be equal in magnitude but opposite in sign to the energy Sally expends: $-1.14 \times 10^4 \text{ J}$)

94. **Sledding** An 845-N sled is pulled a distance of 185 m. The task requires $1.20 \times 10^4 \text{ J}$ of work and is done by pulling on a rope with a force of 125 N. At what angle is the rope held?

$$W = Fd \cos \theta, \text{ so}$$

$$\begin{aligned} \theta &= \cos^{-1}\left(\frac{W}{Fd}\right) = \cos^{-1}\left(\frac{1.20 \times 10^4 \text{ J}}{(125 \text{ N})(185 \text{ m})}\right) \\ &= 58.7^\circ \end{aligned}$$

Chapter 10 continued

Level 3

95. An electric winch pulls a 875-N crate up a 15° incline at 0.25 m/s. The coefficient of friction between the crate and incline is 0.45.

- a. What power does the winch develop?

Work is done on the crate by the winch, gravity, and friction. Because the kinetic energy of the crate does not change, the sum of the three works is equal to zero.

Therefore,

$$W_{\text{winch}} = W_{\text{friction}} + W_{\text{gravity}}$$

$$\text{or, } P_{\text{winch}} = P_{\text{friction}} + P_{\text{gravity}}$$

$$= \frac{\mu F_N d}{t} + \frac{F_g d}{t}$$

$$= \mu F_N \left(\frac{d}{t} \right) + F_g \left(\frac{d}{t} \right)$$

$$= \mu F_N v + F_g v$$

$$= (\mu F_g)(\cos \theta)(v) + F_g v$$

$$= (0.45)(875 \text{ N})(\cos 15^\circ)$$

$$(0.25 \text{ m/s}) +$$

$$(875 \text{ N})(0.25 \text{ m/s})$$

$$= 3.1 \times 10^2 \text{ W}$$

- b. If the winch is 85 percent efficient, what is the electrical power that must be delivered to the winch?

$$e = \frac{W_o}{W_i} = \frac{P_o}{P_i}$$

$$\text{so, } P_i = \frac{P_o}{e}$$

$$= \frac{3.1 \times 10^2 \text{ W}}{0.85}$$

$$= 3.6 \times 10^2 \text{ W}$$

Thinking Critically

page 282

96. **Analyze and Conclude** You work at a store, carrying boxes to a storage loft that is 12 m above the ground. You have 30 boxes with a total mass of 150 kg that must be moved as quickly as possible, so you consider carrying more than one up at a time. If you try to move too many at once, you know that you will go very slowly, resting often. If you carry

only one box at a time, most of the energy will go into raising your own body. The power (in watts) that your body can develop over a long time depends on the mass that you carry, as shown in **Figure 10-25**. This is an example of a power curve that applies to machines as well as to people. Find the number of boxes to carry on each trip that would minimize the time required. What time would you spend doing the job? Ignore the time needed to go back down the stairs and to lift and lower each box.

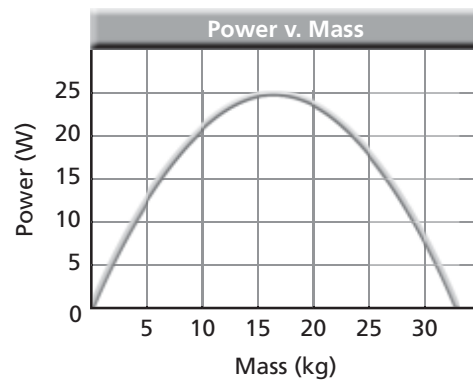

■ Figure 10-25

The work has to be done the same,

$$W = F_g d = mgd$$

$$= (150 \text{ kg})(9.80 \text{ m/s}^2)(12 \text{ m})$$

$$= 1.76 \times 10^4 \text{ J.}$$

From the graph, the maximum power is 25 W at 15 kg. Since the mass per box is

$\frac{150 \text{ kg}}{30 \text{ boxes}} = 5 \text{ kg}$, this represents three boxes.

$$P = \frac{W}{t} \text{ so } t = \frac{W}{P}$$

$$= \frac{1.76 \times 10^4 \text{ J}}{25 \text{ W}}$$

$$= 7.0 \times 10^2 \text{ s}$$

$$= 12 \text{ min}$$

97. **Apply Concepts** A sprinter of mass 75 kg runs the 50.0-m dash in 8.50 s. Assume that the sprinter's acceleration is constant throughout the race.

- a. What is the average power of the sprinter over the 50.0 m?

Chapter 10 continued

Assume constant acceleration, therefore constant force

$$d = d_i + v_i t + \frac{1}{2} a t^2$$

but $d_i = v_i = 0$

$$\begin{aligned} P &= \frac{W}{t} = \frac{Fd}{t} = \frac{mad}{t} = \frac{m\left(\frac{2d}{t^2}\right)d}{t} \\ &= \frac{2md^2}{t^3} = \frac{(2)(75 \text{ kg})(50.0 \text{ m})}{(8.50 \text{ s})^3} \\ &= 6.1 \times 10^2 \text{ W} \end{aligned}$$

- b. What is the maximum power generated by the sprinter?

Power increases linearly from zero, since the velocity increases linearly as shown by

$$P = \frac{W}{t} = \frac{Fd}{t} = F\left(\frac{d}{t}\right) = Fv.$$

Therefore

$$P_{\max} = 2P_{\text{ave}} = 1.2 \times 10^3 \text{ W}$$

- c. Make a quantitative graph of power versus time for the entire race.

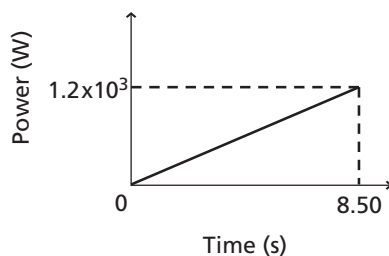

- 98. Apply Concepts** The sprinter in the previous problem runs the 50.0-m dash in the same time, 8.50 s. However, this time the sprinter accelerates in the first second and runs the rest of the race at a constant velocity.

- a. Calculate the average power produced for that first second.

Distance first second +

Distance rest of race = 50.0 m

$$d_f = d_i + v_i t + \frac{1}{2} a t^2$$

$d_i = v_i = 0$ so

$$d_f = \frac{1}{2} a (t_1)^2 + v_f (t_2) = 50.0 \text{ m}$$

Final velocity:

$$v_f = v_i + at$$

$v_i = 0$ so

$$v_f = at = a(t_1)$$

Therefore,

$$\begin{aligned} d_f &= \frac{1}{2} a t_1^2 + a t_1 t_2 \\ &= a \left(\frac{1}{2} t_1^2 + t_1 t_2 \right) \end{aligned}$$

$$a = \frac{d_f}{\frac{1}{2} t_1^2 + t_1 t_2}$$

$$= \frac{50.0 \text{ m}}{\left(\frac{1}{2}\right)(1.00 \text{ s})^2 + (1.00 \text{ s})(7.50 \text{ s})}$$

$$= 6.25 \text{ m/s}^2$$

For the first second:

$$\begin{aligned} d &= \frac{1}{2} a t^2 = \left(\frac{1}{2}\right)(6.25 \text{ m/s}^2)(1.00 \text{ s})^2 \\ &= 3.12 \text{ m} \end{aligned}$$

From Problem 97,

$$P = \frac{mad}{t}$$

$$\begin{aligned} P_{\text{ave}} &= \frac{(75 \text{ kg})(6.25 \text{ m/s}^2)(3.12 \text{ m})}{1.00 \text{ s}} \\ &= 1.5 \times 10^3 \text{ W} \end{aligned}$$

- b. What is the maximum power that the sprinter now generates?

$$P_{\max} = 2P_{\text{ave}} = 3.0 \times 10^3 \text{ W}$$

Writing in Physics

page 282

- 99.** Just as a bicycle is a compound machine, so is an automobile. Find the efficiencies of the component parts of the power train (engine, transmission, wheels, and tires). Explore possible improvements in each of these efficiencies.

The overall efficiency is 15–30 percent. The transmission's efficiency is about 90 percent. Rolling friction in the tires is about 1 percent (ratio of pushing force to weight moved). The largest gain is possible in the engine.

Chapter 10 continued

100. The terms *force*, *work*, *power*, and *energy* often mean the same thing in everyday use. Obtain examples from advertisements, print media, radio, and television that illustrate meanings for these terms that differ from those used in physics.

Answers will vary. Some examples include, the company Consumers' Power changed its name to Consumers' Energy without changing its product, natural gas. "It's not just energy, it's power!" has appeared in the popular press.

Cumulative Review

page 282

101. You are helping your grandmother with some gardening and have filled a garbage can with weeds and soil. Now you have to move the garbage can across the yard and realize it is so heavy that you will need to push it, rather than lift it. If the can has a mass of 24 kg, the coefficient of kinetic friction between the can's bottom and the muddy grass is 0.27, and the static coefficient of friction between those same surfaces is 0.35, how hard do you have to push horizontally to get the can to just start moving? (Chapter 5)

$$\begin{aligned} F_{\text{you on can}} &= F_{\text{friction}} = \mu_s F_N = \mu_s mg \\ &= (0.35)(24 \text{ kg})(9.80 \text{ m/s}^2) \\ &= 82 \text{ N} \end{aligned}$$

102. Baseball If a major league pitcher throws a fastball horizontally at a speed of 40.3 m/s (90 mph) and it travels 18.4 m (60 ft, 6 in), how far has it dropped by the time it crosses home plate? (Chapter 6)

$$\begin{aligned} d_{fx} &= d_{ix} + v_{xt} \\ \text{so } t &= \frac{d_{fx} - d_{ix}}{v_x} \\ &= \frac{18.4 \text{ m} - 0.0 \text{ m}}{40.3 \text{ m/s}} = 0.457 \text{ s} \end{aligned}$$

$$\begin{aligned} d_{fy} &= d_{iy} + v_{iy}t + \frac{1}{2}gt^2 \\ d_{iy} &= v_{iy} = 0 \\ \text{so } d_{fy} &= \frac{1}{2}gt^2 \\ &= \left(\frac{1}{2}\right)(9.80 \text{ m/s}^2)(0.457 \text{ s})^2 \\ &= 1.02 \text{ m} \end{aligned}$$

103. People sometimes say that the Moon stays in its orbit because the "centrifugal force just balances the centripetal force, giving no net force." Explain why this idea is wrong. (Chapter 8)

There is only one force on the moon, the gravitational force of Earth's mass on it. This net force gives it an acceleration which is its centripetal acceleration toward Earth's center.

Challenge Problem

page 268

An electric pump pulls water at a rate of 0.25 m³/s from a well that is 25 m deep. The water leaves the pump at a speed of 8.5 m/s.

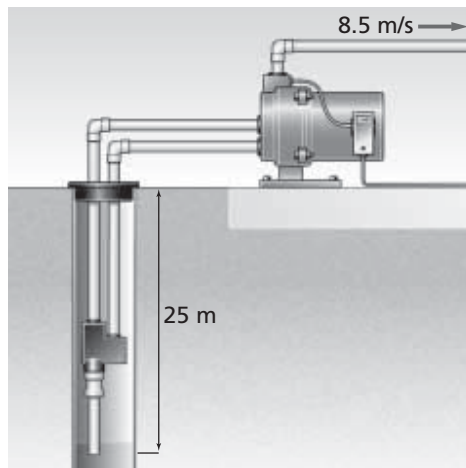

Chapter 10 continued

1. What power is needed to lift the water to the surface?

The work done in lifting is $F_g d = mgd$. Therefore, the power is

$$\begin{aligned} P_{\text{lift}} &= \frac{W}{t} = \frac{F_g d}{t} = \frac{mgd}{t} \\ &= \frac{(0.25 \text{ m}^3)(1.00 \times 10^3 \text{ kg/m}^3)(9.80 \text{ m/s}^2)(25 \text{ m})}{1.0 \text{ s}} \\ &= 6.1 \times 10^4 \text{ W} \\ &= 61 \text{ kW} \end{aligned}$$

2. What power is needed to increase the pump's kinetic energy?

The work done in increasing the pump's kinetic energy is $\frac{1}{2}mv^2$.

Therefore, $P = \frac{W}{t} = \frac{\Delta KE}{t} = \frac{\frac{1}{2}mv^2}{t} = \frac{mv^2}{2t}$

$$\begin{aligned} &= \frac{(0.25 \text{ m}^3)(1.00 \times 10^3 \text{ kg/m}^3)(8.5 \text{ m/s})^2}{(2)(1.0 \text{ s})} \\ &= 9.0 \times 10^3 \text{ W} = 9.0 \text{ kW} \end{aligned}$$

3. If the pump's efficiency is 80 percent, how much power must be delivered to the pump?

$$e = \frac{W_o}{W_i} \times 100 = \frac{\frac{W_o}{t}}{\frac{W_i}{t}} \times 100 = \frac{P_o}{P_i} \times 100 \text{ so,}$$

$$\begin{aligned} P_i &= \frac{P_o}{e} \times 100 = \frac{9.0 \times 10^3 \text{ W}}{80} \times 100 \\ &= 1.1 \times 10^4 \text{ W} \\ &= 11 \text{ kW} \end{aligned}$$

Practice Problems

11.1 The Many Forms of Energy
pages 285–292

page 287

1. A skater with a mass of 52.0 kg moving at 2.5 m/s glides to a stop over a distance of 24.0 m. How much work did the friction of the ice do to bring the skater to a stop? How much work would the skater have to do to speed up to 2.5 m/s again?

To bring the skater to a stop:

$$\begin{aligned} W &= KE_f - KE_i \\ &= \frac{1}{2}mv_f^2 - \frac{1}{2}mv_i^2 \\ &= \frac{1}{2}(52.0 \text{ kg})(0.00 \text{ m/s})^2 - \\ &\quad \frac{1}{2}(52.0 \text{ kg})(2.5 \text{ m/s})^2 \\ &= -160 \text{ J} \end{aligned}$$

To speed up again:

This is the reverse of the first question.

$$\begin{aligned} W &= KE_f - KE_i \\ &= \frac{1}{2}mv_f^2 - \frac{1}{2}mv_i^2 \\ &= \frac{1}{2}(52.0 \text{ kg})(2.5 \text{ m/s})^2 - \\ &\quad \frac{1}{2}(52.0 \text{ kg})(0.00 \text{ m/s})^2 \\ &= +160 \text{ J} \end{aligned}$$

2. An 875.0-kg compact car speeds up from 22.0 m/s to 44.0 m/s while passing another car. What are its initial and final energies, and how much work is done on the car to increase its speed?

The initial kinetic energy of the car is

$$\begin{aligned} KE_i &= \frac{1}{2}mv^2 = \frac{1}{2}(875.0 \text{ kg})(22.0 \text{ m/s})^2 \\ &= 2.12 \times 10^5 \text{ J} \end{aligned}$$

The final kinetic energy is

$$\begin{aligned} KE_f &= \frac{1}{2}mv^2 = \frac{1}{2}(875.0 \text{ kg})(44.0 \text{ m/s})^2 \\ &= 8.47 \times 10^5 \text{ J} \end{aligned}$$

The work done is

$$\begin{aligned} KE_f - KE_i &= 8.47 \times 10^5 \text{ J} - 2.12 \times 10^5 \text{ J} \\ &= 6.35 \times 10^5 \text{ J} \end{aligned}$$

3. A comet with a mass of 7.85×10^{11} kg strikes Earth at a speed of 25.0 km/s. Find the kinetic energy of the comet in joules, and compare the work that is done by Earth in stopping the comet to the 4.2×10^{15} J of energy that was released by the largest nuclear weapon ever built.

$$\begin{aligned} KE &= \frac{1}{2}mv^2 \\ &= \frac{1}{2}(7.85 \times 10^{11} \text{ kg})(2.50 \times 10^4 \text{ m/s})^2 \\ &= 2.45 \times 10^{20} \text{ J} \end{aligned}$$

$$\frac{KE_{\text{comet}}}{KE_{\text{bomb}}} = \frac{2.45 \times 10^{20} \text{ J}}{4.2 \times 10^{15} \text{ J}} = 5.8 \times 10^4$$

5.8×10^4 bombs would be required to produce the same amount of energy used by Earth in stopping the comet.

page 291

4. In Example Problem 1, what is the potential energy of the bowling ball relative to the rack when it is on the floor?

$$\begin{aligned} PE &= mgh \\ &= (7.30 \text{ kg})(9.80 \text{ m/s}^2)(-0.610 \text{ m}) \\ &= -43.6 \text{ J} \end{aligned}$$

5. If you slowly lower a 20.0-kg bag of sand 1.20 m from the trunk of a car to the driveway, how much work do you do?

$$\begin{aligned} W &= Fd \\ &= mg(h_f - h_i) \\ &= (20.0 \text{ kg})(9.80 \text{ m/s}^2)(0.00 \text{ m} - 1.20 \text{ m}) \\ &= -2.35 \times 10^2 \text{ J} \end{aligned}$$

Chapter 11 continued

6. A boy lifts a 2.2-kg book from his desk, which is 0.80 m high, to a bookshelf that is 2.10 m high. What is the potential energy of the book relative to the desk?

$$\begin{aligned}
 PE &= mg(h_f - h_i) \\
 &= (2.2 \text{ kg})(9.80 \text{ m/s}^2)(2.10 \text{ m} - 0.80 \text{ m}) \\
 &= 28 \text{ J}
 \end{aligned}$$

7. If a 1.8-kg brick falls to the ground from a chimney that is 6.7 m high, what is the change in its potential energy?

Choose the ground as the reference level.

$$\begin{aligned}
 \Delta PE &= mg(h_f - h_i) \\
 &= (1.8 \text{ kg})(9.80 \text{ m/s}^2)(0.0 \text{ m} - 6.7 \text{ m}) \\
 &= -1.2 \times 10^2 \text{ J}
 \end{aligned}$$

8. A warehouse worker picks up a 10.1-kg box from the floor and sets it on a long, 1.1-m-high table. He slides the box 5.0 m along the table and then lowers it back to the floor. What were the changes in the energy of the box, and how did the total energy of the box change? (Ignore friction.)

To lift the box to the table:

$$\begin{aligned}
 W &= Fd \\
 &= mg(h_f - h_i) \\
 &= \Delta PE \\
 &= (10.1 \text{ kg})(9.80 \text{ m/s}^2)(1.1 \text{ m} - 0.0 \text{ m}) \\
 &= 1.1 \times 10^2 \text{ J}
 \end{aligned}$$

To slide the box across the table, $W = 0.0$ because the height did not change and we ignored friction.

To lower the box to the floor:

$$\begin{aligned}
 W &= Fd \\
 &= mg(h_f - h_i) \\
 &= \Delta PE \\
 &= (10.1 \text{ kg})(9.80 \text{ m/s}^2)(0.0 \text{ m} - 1.1 \text{ m}) \\
 &= -1.1 \times 10^2 \text{ J}
 \end{aligned}$$

The sum of the three energy changes is $1.1 \times 10^2 \text{ J} + 0.0 \text{ J} + (-1.1 \times 10^2 \text{ J}) = 0.0 \text{ J}$

Section Review

11.1 The Many Forms of Energy pages 285–292

page 292

9. **Elastic Potential Energy** You get a spring-loaded toy pistol ready to fire by compressing the spring. The elastic potential energy of the spring pushes the rubber dart out of the pistol. You use the toy pistol to shoot the dart straight up. Draw bar graphs that describe the forms of energy present in the following instances.

- a. The dart is pushed into the gun barrel, thereby compressing the spring.

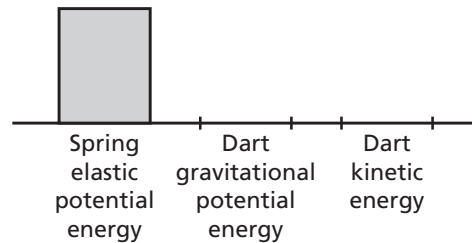

There should be three bars: one for the spring's potential energy, one for gravitational potential energy, and one for kinetic energy. The spring's potential energy is at the maximum level, and the other two are zero.

- b. The spring expands and the dart leaves the gun barrel after the trigger is pulled.

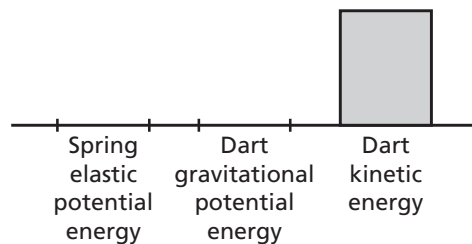

The kinetic energy is at the maximum level, and the other two are zero.

Chapter 11 continued

- c. The dart reaches the top of its flight.

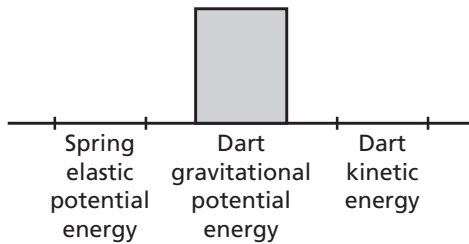

The gravitational potential energy is at the maximum level, and the other two are zero.

10. **Potential Energy** A 25.0-kg shell is shot from a cannon at Earth's surface. The reference level is Earth's surface. What is the gravitational potential energy of the system when the shell is at 425 m? What is the change in potential energy when the shell falls to a height of 225 m?

a. $PE = mgh$

$$= (25.0 \text{ kg})(9.80 \text{ m/s}^2)(425 \text{ m})$$

$$= 1.04 \times 10^5 \text{ J}$$

b. $PE = mgh$

$$= (25.0 \text{ kg})(9.80 \text{ m/s}^2)(225 \text{ m})$$

$$= 5.51 \times 10^4 \text{ J}$$

The change in energy is

$$(1.04 \times 10^5 \text{ J}) - (5.51 \times 10^4 \text{ J})$$

$$= 4.89 \times 10^4 \text{ J}$$

11. **Rotational Kinetic Energy** Suppose some children push a merry-go-round so that it turns twice as fast as it did before they pushed it. What are the relative changes in angular momentum and rotational kinetic energy?

The angular momentum is doubled because it is proportional to the angular velocity. The rotational kinetic energy is quadrupled because it is proportional to the square of the angular velocity. The children did work in rotating the merry-go-round.

12. **Work-Energy Theorem** How can you apply the work-energy theorem to lifting a bowling ball from a storage rack to your shoulder?

The bowling ball has zero kinetic energy when it is resting on the rack or when it is held near your shoulder. Therefore, the total work done on the ball by you and by gravity must equal zero.

13. **Potential Energy** A 90.0-kg rock climber first climbs 45.0 m up to the top of a quarry, then descends 85.0 m from the top to the bottom of the quarry. If the initial height is the reference level, find the potential energy of the system (the climber and Earth) at the top and at the bottom. Draw bar graphs for both situations.

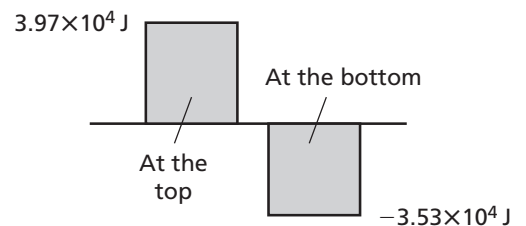

$$PE = mgh$$

At the top,

$$PE = (90.0 \text{ kg})(9.80 \text{ m/s}^2)(+45.0 \text{ m})$$

$$= 3.97 \times 10^4 \text{ J}$$

At the bottom,

$$PE = (90.0 \text{ kg})(9.80 \text{ m/s}^2)$$

$$(+45.0 \text{ m} - 85.0 \text{ m})$$

$$= -3.53 \times 10^4 \text{ J}$$

14. **Critical Thinking** Karl uses an air hose to exert a constant horizontal force on a puck, which is on a frictionless air table. He keeps the hose aimed at the puck, thereby creating a constant force as the puck moves a fixed distance.

- a. Explain what happens in terms of work and energy. Draw bar graphs.

Karl exerted a constant force F over a distance d and did an amount of work $W = Fd$ on the puck. This work changed the kinetic energy of the puck.

Chapter 11 continued

$$\begin{aligned}W &= (KE_f - KE_i) \\&= \frac{1}{2}mv_f^2 - \frac{1}{2}mv_i^2 \\&= \frac{1}{2}mv_f^2\end{aligned}$$

- b. Suppose Karl uses a different puck with half the mass of the first one. All other conditions remain the same. How will the kinetic energy and work differ from those in the first situation?

If the puck has half the mass, it still receives the same amount of work and has the same change in kinetic energy. However, the smaller mass will move faster by a factor of 1.414.

- c. Explain what happened in parts a and b in terms of impulse and momentum.

The two pucks do not have the same final momentum.

Momentum of the first puck:

$$p_1 = m_1v_1$$

Momentum of the second puck:

$$\begin{aligned}p_2 &= m_2v_2 \\&= \left(\frac{1}{2}m_1\right)(1.414v_1) \\&= 0.707 p_1\end{aligned}$$

Thus, the second puck has less momentum than the first puck does. Because the change in momentum is equal to the impulse provided by the air hose, the second puck receives a smaller impulse.

Practice Problems

11.2 Conservation of Energy pages 293–301

page 297

15. A bike rider approaches a hill at a speed of 8.5 m/s. The combined mass of the bike and the rider is 85.0 kg. Choose a suitable system. Find the initial kinetic energy of the system. The rider coasts up the hill. Assuming there is no friction, at what height will the bike come to rest?

The system is the bike + rider + Earth. There are no external forces, so total energy is conserved.

$$\begin{aligned}KE &= \frac{1}{2}mv^2 \\&= \frac{1}{2}(85.0 \text{ kg})(8.5 \text{ m/s})^2 \\&= 3.1 \times 10^3 \text{ J}\end{aligned}$$

$$KE_i + PE_i = KE_f + PE_f$$

$$\frac{1}{2}mv^2 + 0 = 0 + mgh$$

$$\begin{aligned}h &= \frac{v^2}{2g} = \frac{(8.5 \text{ m/s})^2}{(2)(9.80 \text{ m/s}^2)} \\&= 3.7 \text{ m}\end{aligned}$$

16. Suppose that the bike rider in problem 15 pedaled up the hill and never came to a stop. In what system is energy conserved? From what form of energy did the bike gain mechanical energy?

The system of Earth, bike, and rider remains the same, but now the energy involved is not mechanical energy alone. The rider must be considered as having stored energy, some of which is converted to mechanical energy.

Energy came from the chemical potential energy stored in the rider's body.

17. A skier starts from rest at the top of a 45.0-m-high hill, skis down a 30° incline into a valley, and continues up a 40.0-m-high hill. The heights of both hills are measured from the valley floor. Assume that you can neglect friction and the effect of the ski poles. How fast is the skier moving at the bottom of the valley? What is the skier's speed at the top of the next hill? Do the angles of the hills affect your answers?

Bottom of valley:

$$KE_i + PE_i = KE_f + PE_f$$

$$0 + mgh = \frac{1}{2}mv^2 + 0$$

$$v^2 = 2gh$$

$$\begin{aligned}v &= \sqrt{2gh} \\&= \sqrt{(2)(9.80 \text{ m/s}^2)(45.0 \text{ m})}\end{aligned}$$

Chapter 11 continued

$$= 29.7 \text{ m/s}$$

Top of next hill:

$$KE_i + PE_i = KE_f + PE_f$$

$$0 + mgh_i = \frac{1}{2}mv^2 + mgh_f$$

$$v^2 = 2g(h_i - h_f)$$

$$= \sqrt{2g(h_i - h_f)}$$

$$= \sqrt{(2)(9.80 \text{ m/s}^2)(45.0 \text{ m} - 40.0 \text{ m})}$$

$$= 9.90 \text{ m/s}$$

No, the angles do not have any impact.

18. In a belly-flop diving contest, the winner is the diver who makes the biggest splash upon hitting the water. The size of the splash depends not only on the diver's style, but also on the amount of kinetic energy that the diver has. Consider a contest in which each diver jumps from a 3.00-m platform. One diver has a mass of 136 kg and simply steps off the platform. Another diver has a mass of 102 kg and leaps upward from the platform. How high would the second diver have to leap to make a competitive splash?

Using the water as a reference level, the kinetic energy on entry is equal to the potential energy of the diver at the top of his flight. The large diver has $PE = mgh = (136 \text{ kg})(9.80 \text{ m/s}^2)(3.00 \text{ m}) = 4.00 \times 10^3 \text{ J}$

To equal this, the smaller diver would have to jump to

$$h = \frac{4.00 \times 10^3 \text{ J}}{(102 \text{ kg})(9.80 \text{ m/s}^2)} = 4.00 \text{ m}$$

Thus, the smaller diver would have to leap 1.00 m above the platform.

page 300

19. An 8.00-g bullet is fired horizontally into a 9.00-kg block of wood on an air table and is embedded in it. After the collision, the block and bullet slide along the frictionless surface together with a speed of 10.0 cm/s. What was the initial speed of the bullet?

Conservation of momentum:

$$mv = (m + M)V, \text{ or}$$

$$v = \frac{(m + M)V}{m}$$

$$= \frac{(0.00800 \text{ kg} + 9.00 \text{ kg})(0.100 \text{ m/s})}{0.00800 \text{ kg}}$$

$$= 1.13 \times 10^2 \text{ m/s}$$

20. A 0.73-kg magnetic target is suspended on a string. A 0.025-kg magnetic dart, shot horizontally, strikes the target head-on. The dart and the target together, acting like a pendulum, swing 12.0 cm above the initial level before instantaneously coming to rest.
- a. Sketch the situation and choose a system.

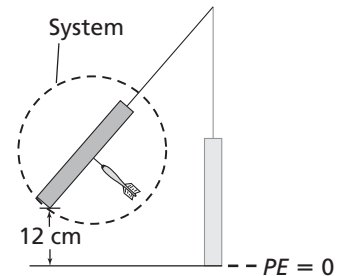

The system includes the suspended target and the dart.

- b. Decide what is conserved in each part and explain your decision.

Only momentum is conserved in the inelastic dart-target collision, so

$$mv_i + MV_i = (m + M)V_f$$

where $V_i = 0$ since the target is initially at rest and V_f is the common velocity just after impact. As the dart-target combination swings upward, energy is conserved, so

$$\Delta PE = \Delta KE \text{ or, at the top of the swing, } (m + M)gh_f = \frac{1}{2}(m + M)(V_f)^2$$

Chapter 11 continued

- c. What was the initial velocity of the dart?

Solve for V_f .

$$V_f = \sqrt{2gh_f}$$

Substitute v_f into the momentum equation and solve for v_i .

$$\begin{aligned} v_i &= \left(\frac{m+M}{m}\right)\sqrt{2gh_f} \\ &= \left(\frac{0.025 \text{ kg} + 0.73 \text{ kg}}{0.025 \text{ kg}}\right)\left(\sqrt{(2)(9.80 \text{ m/s}^2)(0.120 \text{ m})}\right) \\ &= 46 \text{ m/s} \end{aligned}$$

21. A 91.0-kg hockey player is skating on ice at 5.50 m/s. Another hockey player of equal mass, moving at 8.1 m/s in the same direction, hits him from behind. They slide off together.

- a. What are the total energy and momentum in the system before the collision?

$$\begin{aligned} KE_i &= \frac{1}{2}m_1v_1^2 + \frac{1}{2}m_2v_2^2 \\ &= \frac{1}{2}(91.0 \text{ kg})(5.50 \text{ m/s})^2 + \frac{1}{2}(91.0 \text{ kg})(8.1 \text{ m/s})^2 \\ &= 4.4 \times 10^3 \text{ J} \end{aligned}$$

$$\begin{aligned} p_i &= m_1v_1 + m_2v_2 \\ &= (91.0 \text{ kg})(5.5 \text{ m/s}) + (91.0 \text{ kg})(8.1 \text{ m/s}) \\ &= 1.2 \times 10^3 \text{ kg}\cdot\text{m/s} \end{aligned}$$

- b. What is the velocity of the two hockey players after the collision?

After the collision:

$$\begin{aligned} p_i &= p_f \\ m_1v_1 + m_2v_2 &= (m_1 + m_2)v_f \\ v_f &= \frac{m_1v_1 + m_2v_2}{m_1 + m_2} \\ &= \frac{(91.0 \text{ kg})(5.50 \text{ m/s}) + (91.0 \text{ kg})(8.1 \text{ m/s})}{91.0 \text{ kg} + 91.0 \text{ kg}} \\ &= 6.8 \text{ m/s} \end{aligned}$$

- c. How much energy was lost in the collision?

The final kinetic energy is

$$\begin{aligned} KE_f &= \frac{1}{2}(m_i + m_f)v_f^2 \\ &= \frac{1}{2}(91.0 \text{ kg} + 91.0 \text{ kg})(6.8 \text{ m/s})^2 \\ &= 4.2 \times 10^3 \text{ J} \end{aligned}$$

Thus, the energy lost in the collision is

$$\begin{aligned} KE_i - KE_f &= 4.4 \times 10^3 \text{ J} - 4.2 \times 10^3 \text{ J} \\ &= 2 \times 10^2 \text{ J} \end{aligned}$$

Section Review

11.2 Conservation of Energy
pages 293–301

page 301

22. **Closed Systems** Is Earth a closed, isolated system? Support your answer.

To simplify problems that take place over a short time, Earth is considered a closed system. It is not actually isolated, however, because it is acted upon by the gravitational forces from the planets, the Sun, and other stars. In addition, Earth is the recipient of continuous electromagnetic energy, primarily from the Sun.

23. **Energy** A child jumps on a trampoline. Draw bar graphs to show the forms of energy present in the following situations.

- a. The child is at the highest point.

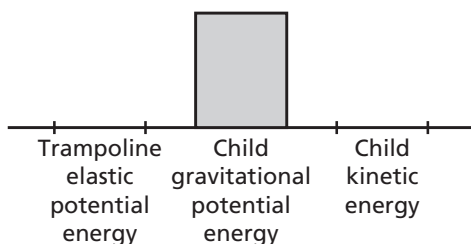

- b. The child is at the lowest point.

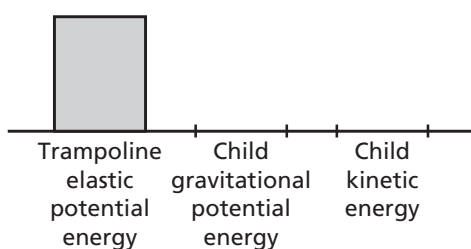

24. **Kinetic Energy** Suppose a glob of chewing gum and a small, rubber ball collide head-on in midair and then rebound apart. Would you expect kinetic energy to be conserved? If not, what happens to the energy?

Even though the rubber ball rebounds with little energy loss, kinetic energy would not be conserved in this case because the glob of chewing gum probably was deformed in the collision.

25. **Kinetic Energy** In table tennis, a very light but hard ball is hit with a hard rubber or wooden paddle. In tennis, a much softer ball is hit with a racket. Why are the two sets of equipment designed in this way? Can you think of other ball-paddle pairs in sports? How are they designed?

The balls and the paddle and racket are designed to match so that the maximum amount of kinetic energy is passed from the paddle or racket to the ball. A softer ball receives energy with less loss from a softer paddle or racket. Other combinations are a golf ball and club (both hard) and a baseball and bat (also both hard).

26. **Potential Energy** A rubber ball is dropped from a height of 8.0 m onto a hard concrete floor. It hits the floor and bounces repeatedly. Each time it hits the floor, it loses $\frac{1}{5}$ of its total energy. How many times will it bounce before it bounces back up to a height of only about 4 m?

$$E_{\text{total}} = mgh$$

Since the rebound height is proportional to energy, each bounce will rebound to $\frac{4}{5}$ the height of the previous bounce.

$$\text{After one bounce: } h = \left(\frac{4}{5}\right)(8 \text{ m}) = 6.4 \text{ m}$$

$$\text{After two bounces: } h = \left(\frac{4}{5}\right)(6.4 \text{ m}) = 5.12 \text{ m}$$

$$\text{After three bounces: } h = \left(\frac{4}{5}\right)(5.12 \text{ m}) = 4.1 \text{ m}$$

Chapter 11 continued

- 27. Energy** As shown in **Figure 11-15**, a 36.0-kg child slides down a playground slide that is 2.5 m high. At the bottom of the slide, she is moving at 3.0 m/s. How much energy was lost as she slid down the slide?



■ **Figure 11-15**

$$\begin{aligned}
 E_i &= mgh \\
 &= (36.0 \text{ kg})(9.80 \text{ m/s}^2)(2.5 \text{ m}) \\
 &= 880 \text{ J} \\
 E_f &= \frac{1}{2}mv^2 \\
 &= \frac{1}{2}(36.0 \text{ kg})(3.0 \text{ m/s})^2 \\
 &= 160 \text{ J} \\
 \text{Energy loss} &= 880 \text{ J} - 160 \text{ J} \\
 &= 720 \text{ J}
 \end{aligned}$$

- 28. Critical Thinking** A ball drops 20 m. When it has fallen half the distance, or 10 m, half of its energy is potential and half is kinetic. When the ball has fallen for half the amount of time it takes to fall, will more, less, or exactly half of its energy be potential energy?
- The ball falls more slowly during the beginning part of its drop. Therefore, in the first half of the time that it falls, it will not have traveled half of the distance that it will fall. Therefore, the ball will have more potential energy than kinetic energy.**

Chapter Assessment

Concept Mapping

page 306

- 29.** Complete the concept map using the following terms: *gravitational potential energy, elastic potential energy, kinetic energy.*

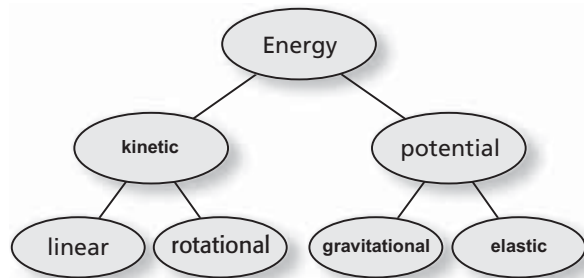

Mastering Concepts

page 306

Unless otherwise directed, assume that air resistance is negligible.

- 30.** Explain how work and a change in energy are related. (11.1)
- The work done on an object causes a change in the object's energy. This is the work-energy theorem.**
- 31.** What form of energy does a wound-up watch spring have? What form of energy does a functioning mechanical watch have? When a watch runs down, what has happened to the energy? (11.1)
- The wound-up watch spring has elastic potential energy. The functioning watch has elastic potential energy and rotational kinetic energy. The watch runs down when all of the energy has been converted to heat by friction in the gears and bearings.**
- 32.** Explain how energy change and force are related. (11.1)
- A force exerted over a distance does work, which produces a change in energy.**
- 33.** A ball is dropped from the top of a building. You choose the top of the building to be the reference level, while your friend chooses the bottom. Explain whether the

Chapter 11 continued

energy calculated using these two reference levels is the same or different for the following situations. (11.1)

- a. the ball's potential energy at any point

The potential energies are different due to the different reference levels.

- b. the change in the ball's potential energy as a result of the fall

The changes in the potential energies as a result of the fall are equal because the change in h is the same for both reference levels.

- c. the kinetic energy of the ball at any point

The kinetic energies of the ball at any point are equal because the velocities are the same.

34. Can the kinetic energy of a baseball ever be negative? (11.1)

The kinetic energy of a baseball can never be negative because the kinetic energy depends on the square of the velocity, which is always positive.

35. Can the gravitational potential energy of a baseball ever be negative? Explain without using a formula. (11.1)

The gravitational potential energy of a baseball can be negative if the height of the ball is lower than the reference level.

36. If a sprinter's velocity increases to three times the original velocity, by what factor does the kinetic energy increase? (11.1)

The sprinter's kinetic energy increases by a factor of 9, because the velocity is squared.

37. What energy transformations take place when an athlete is pole-vaulting? (11.2)

The pole-vaulter runs (kinetic energy) and bends the pole, thereby adding elastic potential energy to the pole. As he/she lifts his/her body, that kinetic and elastic potential energy is transferred into kinetic and gravitational potential energy. When he/she releases the pole, all of his/her energy is kinetic and gravitational potential energy.

38. The sport of pole-vaulting was drastically changed when the stiff, wooden poles were replaced by flexible, fiberglass poles. Explain why. (11.2)

A flexible, fiberglass pole can store elastic potential energy because it can be bent easily. This energy can be released to push the pole-vaulter higher vertically. By contrast, the wooden pole does not store elastic potential energy, and the pole-vaulter's maximum height is limited by the direct conversion of kinetic energy to gravitational potential energy.

39. You throw a clay ball at a hockey puck on ice. The smashed clay ball and the hockey puck stick together and move slowly. (11.2)

- a. Is momentum conserved in the collision? Explain.

The total momentum of the ball and the puck together is conserved in the collision because there are no unbalanced forces on this system.

- b. Is kinetic energy conserved? Explain.

The total kinetic energy is not conserved. Part of it is lost in the smashing of the clay ball and the adhesion of the ball to the puck.

40. Draw energy bar graphs for the following processes. (11.2)

- a. An ice cube, initially at rest, slides down a frictionless slope.

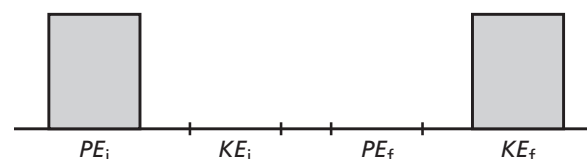

- b. An ice cube, initially moving, slides up a frictionless slope and instantaneously comes to rest.

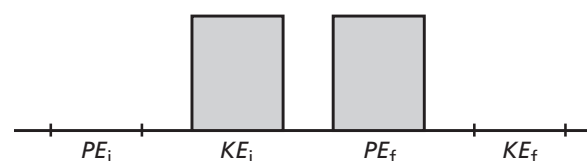

Chapter 11 continued

41. Describe the transformations from kinetic energy to potential energy and vice versa for a roller-coaster ride. (11.2)

On a roller-coaster ride, the car has mostly potential energy at the tops of the hills and mostly kinetic energy at the bottoms of the hills.

42. Describe how the kinetic energy and elastic potential energy are lost in a bouncing rubber ball. Describe what happens to the motion of the ball. (11.2)

On each bounce, some, but not all, of the ball's kinetic energy is stored as elastic potential energy; the ball's deformation dissipates the rest of the energy as thermal energy and sound. After the bounce, the stored elastic potential energy is released as kinetic energy. Due to the energy losses in the deformation, each subsequent bounce begins with a smaller amount of kinetic energy, and results in the ball reaching a lower height.

Eventually, all of the ball's energy is dissipated, and the ball comes to rest.

Applying Concepts

pages 306–307

43. The driver of a speeding car applies the brakes and the car comes to a stop. The system includes the car but not the road. Apply the work-energy theorem to the following situations.

- a. The car's wheels do not skid.

If the car wheels do not skid, the brake surfaces rub against each other and do work that stops the car. The work that the brakes do is equal to the change in kinetic energy of the car. The brake surfaces heat up because the kinetic energy is transformed to thermal energy.

- b. The brakes lock and the car's wheels skid.

If the brakes lock and the car wheels skid, the wheels rubbing on the road are doing the work that stops the car. The tire surfaces heat up, not the brakes. This is not an efficient way to stop a car, and it ruins the tires.

44. A compact car and a trailer truck are both traveling at the same velocity. Did the car engine or the truck engine do more work in accelerating its vehicle?

The trailer truck has more kinetic energy, $KE = \frac{1}{2}mv^2$, because it has greater mass than the compact car. Thus, according to the work-energy theorem, the truck's engine must have done more work.

45. **Catapults** Medieval warriors used catapults to assault castles. Some catapults worked by using a tightly wound rope to turn the catapult arm. What forms of energy are involved in catapulting a rock to the castle wall?

Elastic potential energy is stored in the wound rope, which does work on the rock. The rock has kinetic and potential energy as it flies through the air. When it hits the wall, the inelastic collision causes most of the mechanical energy to be converted to thermal and sound energy and to do work breaking apart the wall structure. Some of the mechanical energy appears in the fragments thrown from the collision.

46. Two cars collide and come to a complete stop. Where did all of their energy go?

The energy went into bending sheet metal on the cars. Energy also was lost due to frictional forces between the cars and the tires, and in the form of thermal energy and sound.

47. During a process, positive work is done on a system, and the potential energy decreases. Can you determine anything about the change in kinetic energy of the system? Explain.

The work equals the change in the total mechanical energy, $W = \Delta(KE + PE)$. If W is positive and ΔPE is negative, then ΔKE must be positive and greater than W .

48. During a process, positive work is done on a system, and the potential energy increases. Can you tell whether the kinetic energy increased, decreased, or remained the same? Explain.

Chapter 11 continued

The work equals the change in the total mechanical energy, $W = \Delta(KE + PE)$. If W is positive and ΔPE is positive, then you cannot say anything conclusive about ΔKE .

49. **Skating** Two skaters of unequal mass have the same speed and are moving in the same direction. If the ice exerts the same frictional force on each skater, how will the stopping distances of their bodies compare?

The larger skater will have more kinetic energy. The kinetic energy of each skater will be dissipated by the negative work, $W = Fd$, done by the friction of the ice. Since the frictional forces are equal, the larger skater will go farther before stopping.

50. You swing a 55-g mass on the end of a 0.75-m string around your head in a nearly horizontal circle at constant speed, as shown in Figure 11-16.

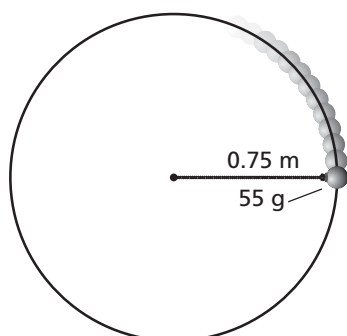

■ Figure 11-16

- a. How much work is done on the mass by the tension of the string in one revolution?
No work is done by the tension force on the mass because the tension is pulling perpendicular to the motion of the mass.
- b. Is your answer to part a in agreement with the work-energy theorem? Explain.
This does not violate the work-energy theorem because the kinetic energy of the mass is constant; it is moving at a constant speed.

51. Give specific examples that illustrate the following processes.
- a. Work is done on a system, thereby increasing kinetic energy with no change in potential energy.
pushing a hockey puck horizontally across ice; system consists of hockey puck only
- b. Potential energy is changed to kinetic energy with no work done on the system.
dropping a ball; system consists of ball and Earth
- c. Work is done on a system, increasing potential energy with no change in kinetic energy.
compressing the spring in a toy pistol; system consists of spring only
- d. Kinetic energy is reduced, but potential energy is unchanged. Work is done by the system.
A car, speeding on a level track, brakes and reduces its speed.

52. **Roller Coaster** You have been hired to make a roller coaster more exciting. The owners want the speed at the bottom of the first hill doubled. How much higher must the first hill be built?

The hill must be made higher by a factor of 4.

53. Two identical balls are thrown from the top of a cliff, each with the same speed. One is thrown straight up, the other straight down. How do the kinetic energies and speeds of the balls compare as they strike the ground?
Even though the balls are moving in opposite directions, they have the same kinetic energy and potential energy when they are thrown. Therefore, they will have the same mechanical energy and speed when they hit the ground.

Chapter 11 continued

Mastering Problems

Unless otherwise directed, assume that air resistance is negligible.

11.1 The Many Forms of Energy

pages 307–308

Level 1

54. A 1600-kg car travels at a speed of 12.5 m/s. What is its kinetic energy?

$$\begin{aligned} KE &= \frac{1}{2}mv^2 = \frac{1}{2}(1600 \text{ kg})(12.5 \text{ m/s})^2 \\ &= 1.3 \times 10^5 \text{ J} \end{aligned}$$

55. A racing car has a mass of 1525 kg. What is its kinetic energy if it has a speed of 108 km/h?

$$\begin{aligned} KE &= \frac{1}{2}mv^2 \\ &= \frac{1}{2}(1525 \text{ kg})\left(\frac{(108 \text{ km/h})(1000 \text{ m/km})}{3600 \text{ s/h}}\right)^2 \\ &= 6.86 \times 10^5 \text{ J} \end{aligned}$$

56. Shawn and his bike have a combined mass of 45.0 kg. Shawn rides his bike 1.80 km in 10.0 min at a constant velocity. What is Shawn's kinetic energy?

$$\begin{aligned} KE &= \frac{1}{2}mv^2 = \frac{1}{2}m\left(\frac{d}{t}\right)^2 \\ &= \frac{1}{2}(45 \text{ kg})\left(\frac{(1.80 \text{ km})(1000 \text{ m/km})}{(10.0 \text{ min})(60 \text{ s/min})}\right)^2 \\ &= 203 \text{ J} \end{aligned}$$

57. Tony has a mass of 45 kg and is moving with a speed of 10.0 m/s.

- a. Find Tony's kinetic energy.

$$\begin{aligned} KE &= \frac{1}{2}mv^2 = \frac{1}{2}(45 \text{ kg})(10.0 \text{ m/s})^2 \\ &= 2.3 \times 10^3 \text{ J} \end{aligned}$$

- b. Tony's speed changes to 5.0 m/s. Now what is his kinetic energy?

$$\begin{aligned} KE &= \frac{1}{2}mv^2 = \frac{1}{2}(45 \text{ kg})(5.0 \text{ m/s})^2 \\ &= 5.6 \times 10^2 \text{ J} \end{aligned}$$

- c. What is the ratio of the kinetic energies in parts a and b? Explain.

$$\frac{\frac{1}{2}(mv_1^2)}{\frac{1}{2}(mv_2^2)} = \frac{v_1^2}{v_2^2} = \frac{(10.0)^2}{(5.0)^2} = \frac{4}{1}$$

Twice the velocity gives four times the kinetic energy. The kinetic energy is proportional to the square of the velocity.

58. Katia and Angela each have a mass of 45 kg, and they are moving together with a speed of 10.0 m/s.

- a. What is their combined kinetic energy?

$$\begin{aligned} KE_c &= \frac{1}{2}mv^2 = \frac{1}{2}(m_K + m_A)v^2 \\ &= \frac{1}{2}(45 \text{ kg} + 45 \text{ kg})(10.0 \text{ m/s})^2 \\ &= 4.5 \times 10^3 \text{ J} \end{aligned}$$

- b. What is the ratio of their combined mass to Katia's mass?

$$\begin{aligned} \frac{m_K + m_A}{m_K} &= \frac{45 \text{ kg} + 45 \text{ kg}}{45 \text{ kg}} \\ &= \frac{2}{1} \end{aligned}$$

- c. What is the ratio of their combined kinetic energy to Katia's kinetic energy? Explain.

$$\begin{aligned} KE_K &= \frac{1}{2}m_Kv^2 = \frac{1}{2}(45 \text{ kg})(10.0 \text{ m/s})^2 \\ &= 2.3 \times 10^3 \text{ J} \end{aligned}$$

$$\begin{aligned} \frac{KE_c}{KE_K} &= \frac{\frac{1}{2}(m_K + m_A)v^2}{\frac{1}{2}m_Kv^2} = \frac{m_K + m_A}{m_K} \\ &= \frac{2}{1} \end{aligned}$$

The ratio of their combined kinetic energy to Katia's kinetic energy is the same as the ratio of their combined mass to Katia's mass. Kinetic energy is proportional to mass.

Chapter 11 continued

59. Train In the 1950s, an experimental train, which had a mass of 2.50×10^4 kg, was powered across a level track by a jet engine that produced a thrust of 5.00×10^5 N for a distance of 509 m.

- a. Find the work done on the train.

$$W = Fd = (5.00 \times 10^5 \text{ N})(509 \text{ m}) \\ = 2.55 \times 10^8 \text{ J}$$

- b. Find the change in kinetic energy.

$$\Delta KE = W = 2.55 \times 10^8 \text{ J}$$

- c. Find the final kinetic energy of the train if it started from rest.

$$\Delta KE = KE_f - KE_i$$

$$\text{so } KE_f = \Delta KE + KE_i$$

$$= 2.55 \times 10^8 \text{ J} + 0.00 \text{ J}$$

$$= 2.55 \times 10^8 \text{ J}$$

- d. Find the final speed of the train if there had been no friction.

$$KE_f = \frac{1}{2}mv_f^2$$

$$\text{So } v_f^2 = \frac{KE_f}{\frac{1}{2}m}$$

$$= \frac{2.55 \times 10^8 \text{ J}}{\frac{1}{2}(2.50 \times 10^4 \text{ kg})}$$

$$\text{So } v_f = \sqrt{2.04 \times 10^4 \text{ m}^2/\text{s}^2} = 143 \text{ m/s}$$

60. Car Brakes A 14,700-N car is traveling at 25 m/s. The brakes are applied suddenly, and the car slides to a stop, as shown in **Figure 11-17**. The average braking force between the tires and the road is 7100 N. How far will the car slide once the brakes are applied?

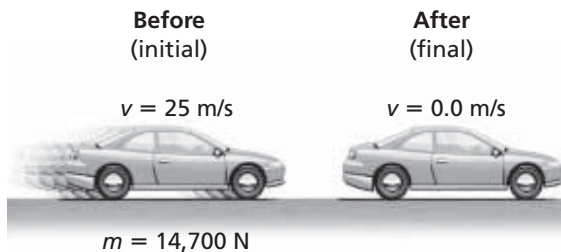

■ **Figure 11-17**

$$W = Fd = \frac{1}{2}mv^2$$

$$\text{Now } m = \frac{F_g}{g}$$

$$\text{So } d = \frac{\frac{1}{2}mv^2}{F}$$

$$= \frac{\frac{1}{2}\left(\frac{F_g}{g}\right)v^2}{F}$$

$$= \frac{\frac{1}{2}\left(\frac{14,700 \text{ N}}{9.80 \text{ m/s}^2}\right)(25.0 \text{ m/s})^2}{7100 \text{ N}}$$

$$= 66 \text{ m}$$

61. A 15.0-kg cart is moving with a velocity of 7.50 m/s down a level hallway. A constant force of 10.0 N acts on the cart, and its velocity becomes 3.20 m/s.

- a. What is the change in kinetic energy of the cart?

$$\Delta KE = KE_f - KE_i = \frac{1}{2}m(v_f^2 - v_i^2)$$

$$= \frac{1}{2}(15.0 \text{ kg})((3.20 \text{ m/s})^2 -$$

$$(7.50 \text{ m/s})^2)$$

$$= -345 \text{ J}$$

- b. How much work was done on the cart?

$$W = \Delta KE = -345 \text{ J}$$

- c. How far did the cart move while the force acted?

$$W = Fd$$

$$\text{so } d = \frac{W}{F} = \frac{-345 \text{ J}}{-10.0 \text{ N}} = 34.5 \text{ m}$$

62. How much potential energy does DeAnna with a mass of 60.0 kg, gain when she climbs a gymnasium rope a distance of 3.5 m?

$$PE = mgh$$

$$= (60.0 \text{ kg})(9.80 \text{ m/s}^2)(3.5 \text{ m})$$

$$= 2.1 \times 10^3 \text{ J}$$

63. Bowling A 6.4-kg bowling ball is lifted 2.1 m into a storage rack. Calculate the increase in the ball's potential energy.

$$PE = mgh$$

$$= (6.4 \text{ kg})(9.80 \text{ m/s}^2)(2.1 \text{ m})$$

$$= 1.3 \times 10^2 \text{ J}$$

Chapter 11 continued

- 64.** Mary weighs 505 N. She walks down a flight of stairs to a level 5.50 m below her starting point. What is the change in Mary's potential energy?

$$\begin{aligned} PE &= mg\Delta h = F_g\Delta h \\ &= (505 \text{ N})(-5.50 \text{ m}) \\ &= -2.78 \times 10^3 \text{ J} \end{aligned}$$

- 65. Weightlifting** A weightlifter raises a 180-kg barbell to a height of 1.95 m. What is the increase in the potential energy of the barbell?

$$\begin{aligned} PE &= mgh \\ &= (180 \text{ kg})(9.80 \text{ m/s}^2)(1.95 \text{ m}) \\ &= 3.4 \times 10^3 \text{ J} \end{aligned}$$

- 66.** A 10.0-kg test rocket is fired vertically from Cape Canaveral. Its fuel gives it a kinetic energy of 1960 J by the time the rocket engine burns all of the fuel. What additional height will the rocket rise?

$$\begin{aligned} PE &= mgh = KE \\ h &= \frac{KE}{mg} = \frac{1960}{(10.0 \text{ kg})(9.80 \text{ m/s}^2)} \\ &= 20.0 \text{ m} \end{aligned}$$

- 67.** Antwan raised a 12.0-N physics book from a table 75 cm above the floor to a shelf 2.15 m above the floor. What was the change in the potential energy of the system?

$$\begin{aligned} PE &= mg\Delta h = F_g\Delta h = F_g(h_f - h_i) \\ &= (12.0 \text{ N})(2.15 \text{ m} - 0.75 \text{ m}) \\ &= 17 \text{ J} \end{aligned}$$

- 68.** A hallway display of energy is constructed in which several people pull on a rope that lifts a block 1.00 m. The display indicates that 1.00 J of work is done. What is the mass of the block?

$$\begin{aligned} W &= PE = mgh \\ m &= \frac{W}{gh} = \frac{1.00 \text{ J}}{(9.80 \text{ m/s}^2)(1.00 \text{ m})} \\ &= 0.102 \text{ kg} \end{aligned}$$

Level 2

- 69. Tennis** It is not uncommon during the serve of a professional tennis player for the racket to exert an average force of 150.0 N on the ball. If the ball has a mass of 0.060 kg and is in contact with the strings of the racket, as shown in **Figure 11-18**, for 0.030 s, what is the kinetic energy of the ball as it leaves the racket? Assume that the ball starts from rest.



■ **Figure 11-18**

$$Ft = m\Delta v = mv_f - mv_i \text{ and } v_i = 0$$

$$\begin{aligned} \text{so } v_f &= \frac{Ft}{m} = \frac{(150.0 \text{ N})(3.0 \times 10^{-2} \text{ s})}{6.0 \times 10^{-2} \text{ kg}} \\ &= 75 \text{ m/s} \end{aligned}$$

$$\begin{aligned} KE &= \frac{1}{2}mv^2 \\ &= \frac{1}{2}(6.0 \times 10^{-2} \text{ kg})(75 \text{ m/s})^2 \\ &= 1.7 \times 10^2 \text{ J} \end{aligned}$$

- 70.** Pam, wearing a rocket pack, stands on frictionless ice. She has a mass of 45 kg. The rocket supplies a constant force for 22.0 m, and Pam acquires a speed of 62.0 m/s.

- a.** What is the magnitude of the force?

$$\begin{aligned} \Delta KE_f &= \frac{1}{2}mv_f^2 \\ &= \frac{1}{2}(45 \text{ kg})(62.0 \text{ m/s})^2 \\ &= 8.6 \times 10^4 \text{ J} \end{aligned}$$

- b.** What is Pam's final kinetic energy?

Work done on Pam equals her change in kinetic energy.

$$\begin{aligned} W &= Fd = \Delta KE = KE_f - KE_i \\ KE_i &= 0 \text{ J} \end{aligned}$$

$$\begin{aligned} \text{So, } F &= \frac{KE_f}{d} = \frac{8.6 \times 10^4 \text{ J}}{22.0 \text{ m}} \\ &= 3.9 \times 10^3 \text{ N} \end{aligned}$$

Chapter 11 continued

- 71. Collision** A 2.00×10^3 -kg car has a speed of 12.0 m/s. The car then hits a tree. The tree doesn't move, and the car comes to rest, as shown in **Figure 11-19**.

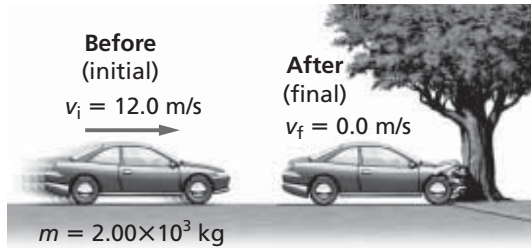

■ **Figure 11-19**

- a. Find the change in kinetic energy of the car.

$$\begin{aligned} \Delta KE &= KE_f - KE_i = \frac{1}{2}m(v_f^2 - v_i^2) \\ &= \frac{1}{2}(2.00 \times 10^3 \text{ kg})((0.0 \text{ m/s})^2 - (12.0 \text{ m/s})^2) \\ &= -1.44 \times 10^5 \text{ J} \end{aligned}$$

- b. Find the amount of work done as the front of the car crashes into the tree.

$$W = \Delta KE = -1.44 \times 10^5 \text{ J}$$

- c. Find the size of the force that pushed in the front of the car by 50.0 cm.

$$W = Fd$$

$$\begin{aligned} \text{so } F &= \frac{W}{d} \\ &= \frac{-1.44 \times 10^5 \text{ J}}{0.500 \text{ m}} \\ &= -2.88 \times 10^5 \text{ N} \end{aligned}$$

- 72.** A constant net force of 410 N is applied upward to a stone that weighs 32 N. The upward force is applied through a distance of 2.0 m, and the stone is then released. To what height, from the point of release, will the stone rise?

$$W = Fd = (410 \text{ N})(2.0 \text{ m}) = 8.2 \times 10^2 \text{ J}$$

$$\text{But } W = \Delta PE = mg\Delta h, \text{ so}$$

$$\Delta h = \frac{W}{mg} = \frac{8.2 \times 10^2 \text{ J}}{32 \text{ N}} = 26 \text{ m}$$

11.2 Conservation of Energy

pages 308–309

Level 1

- 73.** A 98.0-N sack of grain is hoisted to a storage room 50.0 m above the ground floor of a grain elevator.

- a. How much work was done?

$$\begin{aligned} W &= \Delta PE = mg\Delta h = F_g\Delta h \\ &= (98.0 \text{ N})(50.0 \text{ m}) \\ &= 4.90 \times 10^3 \text{ J} \end{aligned}$$

- b. What is the increase in potential energy of the sack of grain at this height?

$$\Delta PE = W = 4.90 \times 10^3 \text{ J}$$

- c. The rope being used to lift the sack of grain breaks just as the sack reaches the storage room. What kinetic energy does the sack have just before it strikes the ground floor?

$$KE = \Delta PE = 4.90 \times 10^3 \text{ J}$$

- 74.** A 20-kg rock is on the edge of a 100-m cliff, as shown in **Figure 11-20**.

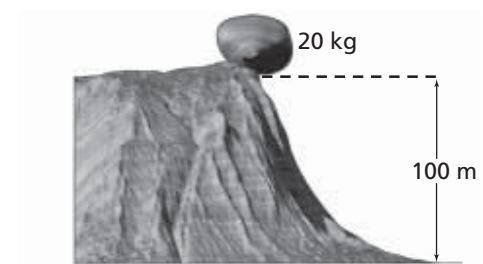

■ **Figure 11-20**

- a. What potential energy does the rock possess relative to the base of the cliff?

$$\begin{aligned} PE &= mgh = (20 \text{ kg})(9.80 \text{ m/s}^2)(100 \text{ m}) \\ &= 2 \times 10^4 \text{ J} \end{aligned}$$

- b. The rock falls from the cliff. What is its kinetic energy just before it strikes the ground?

$$KE = \Delta PE = 2 \times 10^4 \text{ J}$$

- c. What speed does the rock have as it strikes the ground?

$$KE = \frac{1}{2}mv^2$$

$$\begin{aligned} v &= \sqrt{\frac{2KE}{m}} = \sqrt{\frac{(2)(2 \times 10^4 \text{ J})}{20 \text{ kg}}} \\ &= 40 \text{ m/s} \end{aligned}$$

Chapter 11 continued

75. Archery An archer puts a 0.30-kg arrow to the bowstring. An average force of 201 N is exerted to draw the string back 1.3 m.

- a. Assuming that all the energy goes into the arrow, with what speed does the arrow leave the bow?

Work done on the string increases the string's elastic potential energy.

$$W = \Delta PE = Fd$$

All of the stored potential energy is transformed to the arrow's kinetic energy.

$$KE = \frac{1}{2}mv^2 = \Delta PE = Fd$$

$$v^2 = \frac{2Fd}{m}$$

$$v = \sqrt{\frac{2Fd}{m}} = \sqrt{\frac{(2)(201 \text{ N})(1.3 \text{ m})}{0.30 \text{ kg}}} = 42 \text{ m/s}$$

- b. If the arrow is shot straight up, how high does it rise?

The change in the arrow's potential energy equals the work done to pull the string.

$$\Delta PE = mg\Delta h = Fd$$

$$\Delta h = \frac{Fd}{mg} = \frac{(201 \text{ N})(1.3 \text{ m})}{(0.30 \text{ kg})(9.80 \text{ m/s}^2)} = 89 \text{ m}$$

76. A 2.0-kg rock that is initially at rest loses 407 J of potential energy while falling to the ground. Calculate the kinetic energy that the rock gains while falling. What is the rock's speed just before it strikes the ground?

$$PE_i + KE_i = PE_f + KE_f$$

$$KE_i = 0$$

So,

$$KE_f = PE_i - PE_f = 407 \text{ J}$$

$$KE_f = \frac{1}{2}mv_f^2$$

$$v_f^2 = \frac{2KE_f}{m}$$

$$v_f = \sqrt{\frac{2KE_f}{m}} = \sqrt{\frac{(2)(407 \text{ J})}{(2.0 \text{ kg})}} = 2.0 \times 10^1 \text{ m/s}$$

77. A physics book of unknown mass is dropped 4.50 m. What speed does the book have just before it hits the ground?

$$KE = PE$$

$$\frac{1}{2}mv^2 = mgh$$

The mass of the book divides out, so

$$\frac{1}{2}v^2 = gh$$

$$v = \sqrt{2gh} = \sqrt{2(9.80 \text{ m/s}^2)(4.50 \text{ m})} = 9.39 \text{ m/s}$$

78. Railroad Car A railroad car with a mass of 5.0×10^5 kg collides with a stationary railroad car of equal mass. After the collision, the two cars lock together and move off at 4.0 m/s, as shown in **Figure 11-21**.

$$m = 5.0 \times 10^5 \text{ kg}$$

$$v = 4.0 \text{ m/s}$$



■ **Figure 11-21**

- a. Before the collision, the first railroad car was moving at 8.0 m/s. What was its momentum?

$$mv = (5.0 \times 10^5 \text{ kg})(8.0 \text{ m/s}) = 4.0 \times 10^6 \text{ kg}\cdot\text{m/s}$$

- b. What was the total momentum of the two cars after the collision?

Because momentum is conserved, it must be 4.0×10^6 kg·m/s

- c. What were the kinetic energies of the two cars before and after the collision?

Before the collision:

$$KE_i = \frac{1}{2}mv^2 = \frac{1}{2}(5.0 \times 10^5 \text{ kg})(8.0 \text{ m/s})^2 = 1.6 \times 10^7 \text{ J}$$

After the collision:

$$KE_f = \frac{1}{2}mv^2$$

Chapter 11 continued

$$= \frac{1}{2}(5.0 \times 10^5 \text{ kg} + 5.0 \times 10^5 \text{ kg})(4.0 \text{ m/s})^2 = 8.0 \times 10^6 \text{ J}$$

- d. Account for the loss of kinetic energy.

While momentum was conserved during the collision, kinetic energy was not. The amount not conserved was turned into thermal energy and sound energy.

79. From what height would a compact car have to be dropped to have the same kinetic energy that it has when being driven at $1.00 \times 10^2 \text{ km/h}$?

$$v = (1.00 \times 10^2 \frac{\text{km}}{\text{h}}) \left(\frac{1000 \text{ m}}{1 \text{ km}} \right) \left(\frac{1 \text{ h}}{3600 \text{ s}} \right)$$

$$= 27.8 \text{ m/s}$$

$$KE = PE$$

$$\frac{1}{2}mv^2 = mgh$$

$$\frac{1}{2}v^2 = gh$$

$$h = \frac{v^2}{2g} = \frac{(27.8 \text{ m/s})^2}{2(9.80 \text{ m/s}^2)} = 39.4 \text{ m}$$

Level 2

80. Kelli weighs 420 N, and she is sitting on a playground swing that hangs 0.40 m above the ground. Her mom pulls the swing back and releases it when the seat is 1.00 m above the ground.

- a. How fast is Kelli moving when the swing passes through its lowest position?

$$\Delta PE = mg\Delta h = mg(h_f - h_i)$$

$$\Delta KE = \frac{1}{2}m(v_f^2 - v_i^2) = \frac{1}{2}mv_f^2$$

By conservation of mechanical energy:

$$\Delta PE + \Delta KE = 0$$

$$mg(h_f - h_i) + \frac{1}{2}mv_f^2 = 0$$

$$v_f = \sqrt{2g(h_i - h_f)}$$

$$= \sqrt{(2)(9.80 \text{ m/s}^2)(1.00 \text{ m} - 0.40 \text{ m})}$$

$$= 3.4 \text{ m/s}$$

- b. If Kelli moves through the lowest point at 2.0 m/s, how much work was done on the swing by friction?

The work done by friction equals the change in mechanical energy.

$$W = \Delta PE - \Delta KE$$

$$= mg(h_f - h_i) + \frac{1}{2}mv_f^2$$

$$= (420 \text{ N})(0.40 \text{ m} - 1.00 \text{ m}) +$$

$$\frac{1}{2} \left(\frac{420 \text{ N}}{9.80 \text{ m/s}^2} \right) (2.0 \text{ m/s})^2$$

$$= -1.7 \times 10^2 \text{ J}$$

81. Hakeem throws a 10.0-g ball straight down from a height of 2.0 m. The ball strikes the floor at a speed of 7.5 m/s. What was the initial speed of the ball?

$$KE_f = KE_i + PE_i$$

$$\frac{1}{2}mv_f^2 = \frac{1}{2}mv_i^2 + mgh$$

the mass of the ball divides out, so

$$v_i^2 = v_f^2 - 2gh,$$

$$v_i = \sqrt{v_f^2 - 2gh}$$

$$= \sqrt{(7.5 \text{ m/s})^2 - (2)(9.80 \text{ m/s}^2)(2.0 \text{ m})}$$

$$= 4.1 \text{ m/s}$$

82. **Slide** Lorena's mass is 28 kg. She climbs the 4.8-m ladder of a slide and reaches a velocity of 3.2 m/s at the bottom of the slide. How much work was done by friction on Lorena?

The work done by friction on Lorena equals the change in her mechanical energy.

$$W = \Delta PE + \Delta KE$$

$$= mg(h_f - h_i) + \frac{1}{2}m(v_f^2 - v_i^2)$$

$$= (28 \text{ kg})(9.80 \text{ m/s}^2)(0.0 \text{ m} - 4.8 \text{ m}) +$$

$$\frac{1}{2}(28 \text{ kg})((3.2 \text{ m/s})^2 - (0.0 \text{ m/s})^2)$$

$$= -1.2 \times 10^3 \text{ J}$$

83. A person weighing 635 N climbs up a ladder to a height of 5.0 m. Use the person and Earth as the system.

Chapter 11 continued

- a. Draw energy bar graphs of the system before the person starts to climb the ladder and after the person stops at the top. Has the mechanical energy changed? If so, by how much?

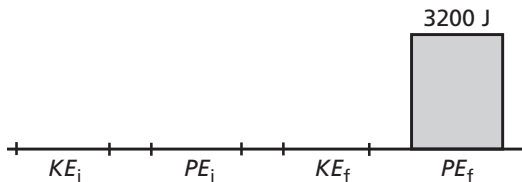

Yes. The mechanical energy has changed, increase in potential energy of $(635 \text{ N})(5.0 \text{ m}) = 3200 \text{ J}$.

- b. Where did this energy come from?
from the internal energy of the person

Mixed Review

pages 309–310

Level 1

84. Suppose a chimpanzee swings through the jungle on vines. If it swings from a tree on a 13-m-long vine that starts at an angle of 45° , what is the chimp's velocity when it reaches the ground?

The chimpanzee's initial height is

$$h = (13 \text{ m})(1 - \cos 45^\circ) = 3.8 \text{ m}$$

Conservation of mechanical energy:

$$\Delta PE + \Delta KE = 0$$

$$mg(h_f - h_i) + \frac{1}{2}m(v_f^2 - v_i^2) = 0$$

$$-mgh_i + \frac{1}{2}mv_f^2 = 0$$

$$v_f = \sqrt{2gh_i} = \sqrt{2(9.80 \text{ m/s}^2)(3.8 \text{ m})}$$

$$= 8.6 \text{ m/s}$$

85. An 0.80-kg cart rolls down a frictionless hill of height 0.32 m. At the bottom of the hill, the cart rolls on a flat surface, which exerts a frictional force of 2.0 N on the cart. How far does the cart roll on the flat surface before it comes to a stop?

$$E = mgh = W = Fd$$

$$d = \frac{mgh}{F} = \frac{(0.80 \text{ kg})(9.80 \text{ m/s}^2)(0.32 \text{ m})}{2.0 \text{ N}}$$

$$= 1.3 \text{ m}$$

86. **High Jump** The world record for the men's high jump is about 2.45 m. To reach that height, what is the minimum amount of work that a 73.0-kg jumper must exert in pushing off the ground?

$$W = \Delta E = mgh$$

$$= (73.0 \text{ kg})(9.80 \text{ m/s}^2)(2.45 \text{ m})$$

$$= 1.75 \text{ kJ}$$

87. A stuntwoman finds that she can safely break her fall from a one-story building by landing in a box filled to a 1-m depth with foam peanuts. In her next movie, the script calls for her to jump from a five-story building. How deep a box of foam peanuts should she prepare?

Assume that the foam peanuts exert a constant force to slow him down,

$W = Fd = E = mgh$. If the height is increased five times, then the depth of the foam peanuts also should be increased five times to 5 m.

Level 2

88. **Football** A 110-kg football linebacker has a head-on collision with a 150-kg defensive end. After they collide, they come to a complete stop. Before the collision, which player had the greater momentum and which player had the greater kinetic energy?

The momentum after the collision is zero; therefore, the two players had equal and opposite momenta before the collision. That is,

$$p_{\text{linebacker}} = m_{\text{linebacker}}v_{\text{linebacker}} = p_{\text{end}} = m_{\text{end}}v_{\text{end}}$$

After the collision, each had zero energy. The energy loss for each

$$\text{player was } \frac{1}{2}mv^2 = \frac{1}{2}\left(\frac{m^2v^2}{m}\right) = \frac{p^2}{2m}.$$

Because the momenta were equal but $m_{\text{linebacker}} < m_{\text{end}}$ the linebacker lost more energy.

89. A 2.0-kg lab cart and a 1.0-kg lab cart are held together by a compressed spring. The lab carts move at 2.1 m/s in one direction. The spring suddenly becomes uncompressed and pushes the two lab carts apart. The 2-kg

Chapter 11 continued

lab cart comes to a stop, and the 1.0-kg lab cart moves ahead. How much energy did the spring add to the lab carts?

$$E_i = \frac{1}{2}mv^2 = \frac{1}{2}(2.0 \text{ kg} + 1.0 \text{ kg})(2.1 \text{ m/s})^2$$

$$= 6.6 \text{ J}$$

$$p_i = mv = (2.0 \text{ kg} + 1.0 \text{ kg})(2.1 \text{ m/s})$$

$$= 6.3 \text{ kg}\cdot\text{m/s} = p_f = (1.0 \text{ kg})v_f$$

$$\text{so, } v_f = 6.3 \text{ m/s}$$

$$E_f = \frac{1}{2}mv_f^2 = \frac{1}{2}(1.0 \text{ kg})(6.3 \text{ m/s})^2 = 19.8 \text{ J}$$

$$\Delta E = 19.8 \text{ J} - 6.6 \text{ J} = 13.2 \text{ J}$$

13.2 J was added by the spring.

90. A 55.0-kg scientist roping through the top of a tree in the jungle sees a lion about to attack a tiny antelope. She quickly swings down from her 12.0-m-high perch and grabs the antelope (21.0 kg) as she swings. They barely swing back up to a tree limb out of reach of the lion. How high is this tree limb?

$$E_i = m_Bgh$$

The velocity of the botanist when she reaches the ground is

$$E_i = \frac{1}{2}m_Bv^2 = m_Bgh$$

$$v = \sqrt{\frac{2E_i}{m}} = \sqrt{\frac{2m_Bgh}{m_B}} = \sqrt{2gh}$$

Momentum is conserved when the botanist grabs the antelope.

$$m_Bv = (m_B + m_A)v_f$$

$$\text{so, } v_f = \frac{m_Bv}{(m_B + m_A)} = \left(\frac{m_B}{m_B + m_A}\right)\sqrt{2gh}$$

The final energy of the two is

$$E_f = \frac{1}{2}(m_B + m_A)v_f^2$$

$$= \frac{1}{2}(m_B + m_A)\left(\frac{m_B}{m_B + m_A}\right)^2(2gh)$$

$$= (m_B + m_A)gh_f$$

$$\text{So, } h_f = \left(\frac{m_B}{m_B + m_A}\right)^2 h$$

$$= \left(\frac{55.0 \text{ kg}}{55.0 \text{ kg} + 21.0 \text{ kg}}\right)^2 (12.0 \text{ m})$$

$$= 6.28 \text{ m}$$

91. An 0.80-kg cart rolls down a 30.0° hill from a vertical height of 0.50 m as shown in **Figure 11-22**. The distance that the cart must roll to the bottom of the hill is $0.50 \text{ m}/\sin 30.0^\circ = 1.0 \text{ m}$. The surface of the hill exerts a frictional force of 5.0 N on the cart. Does the cart roll to the bottom of the hill?

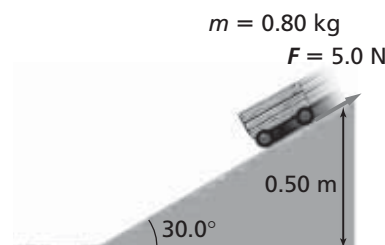

■ Figure 11-22

$$E_i = mgh = (0.80 \text{ kg})(9.80 \text{ m/s}^2)(0.50 \text{ m})$$

$$= 3.9 \text{ J}$$

The work done by friction over 1.0 m would be

$$W = Fd = (5.0 \text{ N})(1.0 \text{ m}) = 5.0 \text{ J.}$$

The work done by friction is greater than the energy of the cart. The cart would not reach the bottom of the hill.

Level 3

92. Object A, sliding on a frictionless surface at 3.2 m/s, hits a 2.0-kg object, B, which is motionless. The collision of A and B is completely elastic. After the collision, A and B move away from each other at equal and opposite speeds. What is the mass of object A?

$$p_i = m_Av_1 + 0$$

$$p_f = m_A(-v_2) + m_Bv_2$$

$$p_i = p_f \text{ (conservation of momentum)}$$

$$\text{therefore, } m_Av_1 = m_A(-v_2) + m_Bv_2$$

$$(m_B - m_A)v_2 = m_Av_1$$

$$v_2 = \frac{(m_Av_1)}{(m_B - m_A)}$$

$$E_i = \frac{1}{2}m_Av_1^2$$

$$E_f = \frac{1}{2}m_Av_2^2 + \frac{1}{2}m_Bv_2^2$$

Chapter 11 continued

$$E_f = \frac{1}{2}(m_A + m_B)v_2^2$$

$$= \frac{1}{2}(m_A + m_B)\left(\frac{m_A v_1}{(m_B - m_A)}\right)^2$$

$E_i = E_f$ (conservation of energy in elastic collision)

therefore,

$$\frac{1}{2}m_A v_1^2 = \frac{1}{2}(m_A + m_B)$$

$$\left(\frac{m_A v_1}{(m_B - m_A)}\right)^2$$

After cancelling out common factors,

$$(m_A + m_B)m_A = (m_B - m_A)^2 =$$

$$m_B^2 - 2m_A m_B + m_A^2$$

$$m_A = \frac{m_B}{3} = \frac{2.00 \text{ kg}}{3} = 0.67 \text{ kg}$$

93. **Hockey** A 90.0-kg hockey player moving at 5.0 m/s collides head-on with a 110-kg hockey player moving at 3.0 m/s in the opposite direction. After the collision, they move off together at 1.0 m/s. How much energy was lost in the collision?

Before: $E = \frac{1}{2}mv_1^2 + \frac{1}{2}mv_2^2$

$$= \frac{1}{2}(90.0 \text{ kg})(5.0 \text{ m/s})^2 +$$

$$\frac{1}{2}(110 \text{ kg})(3.0 \text{ m/s})^2$$

$$= 1.6 \times 10^3 \text{ J}$$

After: $E = \frac{1}{2}(m + m)v_f^2$

$$= \frac{1}{2}(200.0 \text{ kg})(1.0 \text{ m/s})^2$$

$$= 1.0 \times 10^2 \text{ J}$$

Energy loss = $1.6 \times 10^3 \text{ J} - 1.0 \times 10^2 \text{ J}$

$$= 1.5 \times 10^3 \text{ J}$$

Thinking Critically

page 310

94. **Apply Concepts** A golf ball with a mass of 0.046 kg rests on a tee. It is struck by a golf club with an effective mass of 0.220 kg and a speed of 44 m/s. Assuming that the collision is elastic, find the speed of the ball when it leaves the tee.

From the conservation of momentum,

$$m_c v_{c1} = m_c v_{c2} + m_b v_{b2}$$

Solve for v_{c2} , $v_{c2} = v_{c1} - \frac{m_b v_{b2}}{m_c}$

From conservation of energy,

$$\frac{1}{2}m_c v_{c1}^2 = \frac{1}{2}m_c v_{c2}^2 + \frac{1}{2}m_b v_{b2}^2$$

Multiply by two and substitute to get:

$$m_c v_{c1}^2 = m_c \left(v_{c1} - \frac{m_b v_{b2}}{m_c}\right)^2 + m_b v_{b2}^2$$

or $m_c v_{c1}^2 = m_c v_{c1}^2 - 2m_b v_{c2} v_{c1} +$

$$\frac{m_b^2 v_{b2}^2}{m_c} + m_b v_{b2}^2$$

Simplify and factor:

$$0 = (m_b v_{b2}) \left(-2v_{c1} + \frac{m_b v_{b2}}{m_c} + v_{b2}\right)$$

$m_b v_{b2} = 0$ or

$$-2v_{c1} + \left(\frac{m_b}{m_c} + 1\right)v_{b2} = 0$$

Ignoring the solution $v_{b2} = 0$, then

$$v_{b2} = \frac{2v_{c1}}{\left(\frac{m_b}{m_c} + 1\right)}$$

$$= \frac{2(44 \text{ m/s})}{\left(\frac{0.046 \text{ kg}}{0.220 \text{ kg}} + 1\right)} = 73 \text{ m/s}$$

95. **Apply Concepts** A fly hitting the windshield of a moving pickup truck is an example of a collision in which the mass of one of the objects is many times larger than the other. On the other hand, the collision of two billiard balls is one in which the masses of both objects are the same. How is energy transferred in these collisions? Consider an elastic collision in which billiard ball m_1 has velocity v_1 and ball m_2 is motionless.

- a. If $m_1 = m_2$, what fraction of the initial energy is transferred to m_2 ?

If $m_1 = m_2$, we know that m_1 will be at rest after the collision and m_2 will move with velocity v_1 . All of the energy will be transferred to m_2 .

Chapter 11 continued

- b. If $m_1 \gg m_2$, what fraction of the initial energy is transferred to m_2 ?
If $m_1 \gg m_2$, we know that the motion of m_1 will be unaffected by the collision and that the energy transfer to m_2 will be minimal.
- c. In a nuclear reactor, neutrons must be slowed down by causing them to collide with atoms. (A neutron is about as massive as a proton.) Would hydrogen, carbon, or iron atoms be more desirable to use for this purpose?

The best way to stop a neutron is to have it hit a hydrogen atom, which has about the same mass as the neutron.

- 96. Analyze and Conclude** In a perfectly elastic collision, both momentum and mechanical energy are conserved. Two balls, with masses m_A and m_B , are moving toward each other with speeds v_A and v_B , respectively. Solve the appropriate equations to find the speeds of the two balls after the collision.

conservation of momentum

$$(1) m_A v_{A1} + m_B v_{B1} = m_A v_{A2} + m_B v_{B2}$$

$$m_A v_{A1} - m_A v_{A2} = -m_B v_{B1} + m_B v_{B2}$$

$$(2) m_A(v_{A1} - v_{A2}) = -m_B(v_{B1} - v_{B2})$$

conservation of energy

$$\frac{1}{2} m_A v_{A1}^2 + \frac{1}{2} m_B v_{B1}^2 = \frac{1}{2} m_A v_{A2}^2 + \frac{1}{2} m_B v_{B2}^2$$

$$m_A v_{A1}^2 - m_A v_{A2}^2 = -m_B v_{B1}^2 + m_B v_{B2}^2$$

$$m_A(v_{A1}^2 - v_{A2}^2) = -m_B(v_{B1}^2 - v_{B2}^2)$$

$$(3) m_A(v_{A1} + v_{A2})(v_{A1} - v_{A2}) = -m_B(v_{B1} + v_{B2})(v_{B1} - v_{B2})$$

Divide equation (3) by (2) to obtain

$$(4) v_{A1} + v_{A2} = v_{B1} + v_{B2}$$

Solve equation (1) for v_{A2} and v_{B2}

$$v_{A2} = v_{A1} + \frac{m_B}{m_A}(v_{B1} - v_{B2})$$

$$v_{B2} = v_{B1} + \frac{m_A}{m_B}(v_{A1} - v_{A2})$$

Substitute into (4) and solve for v_{B2} and v_{A2}

$$v_{A1} + v_{A1} + \frac{m_B}{m_A}(v_{B1} - v_{B2}) = v_{B1} + v_{B2}$$

$$2m_A v_{A1} + m_B v_{B1} - m_B v_{B2} = m_A v_{B1} + m_A v_{B2}$$

$$v_{B2} = \left(\frac{2m_A}{m_A + m_B}\right)v_{A1} + \left(\frac{m_B - m_A}{m_A + m_B}\right)v_{B1}$$

$$v_{A1} + v_{A2} = v_{B1} + v_{B1} + \frac{m_A}{m_B}(v_{A1} - v_{A2})$$

$$m_B v_{A1} + m_B v_{A2} = 2m_B v_{B1} + m_A v_{A1} - m_A v_{A2}$$

$$v_{A2} = \left(\frac{m_A - m_B}{m_A + m_B}\right)v_{A1} + \left(\frac{2m_B}{m_A + m_B}\right)v_{B1}$$

Chapter 11 continued

- 97. Analyze and Conclude** A 25-g ball is fired with an initial speed of v_1 toward a 125-g ball that is hanging motionless from a 1.25-m string. The balls have a perfectly elastic collision. As a result, the 125-g ball swings out until the string makes an angle of 37.0° with the vertical. What is v_1 ?

Object 1 is the incoming ball. Object 2 is the one attached to the string.
In the collision, momentum is conserved.

$$p_{1i} = p_{1f} + p_{2f} \text{ or}$$

$$m_1 v_{1i} = m_1 v_{1f} + m_2 v_{2f}$$

In the collision, kinetic energy is conserved.

$$\frac{1}{2} m_1 v_{1i}^2 = \frac{1}{2} m_1 v_{1f}^2 + \frac{1}{2} m_2 v_{2f}^2$$

$$m_1 v_{1i}^2 = m_1 v_{1f}^2 + m_2 v_{2f}^2$$

$$(m_1 v_{1i}^2) \left(\frac{m_1}{m_1} \right) = (m_1 v_{1f}^2) \left(\frac{m_1}{m_1} \right) + (m_2 v_{2f}^2) \left(\frac{m_2}{m_2} \right)$$

$$\frac{m_1^2 v_{1i}^2}{m_1} = \frac{m_1^2 v_{1f}^2}{m_1} + \frac{m_2^2 v_{2f}^2}{m_2}$$

$$\frac{p_{1i}^2}{m_1} = \frac{p_{1f}^2}{m_1} + \frac{p_{2f}^2}{m_2}$$

$$p_{1i}^2 = p_{1f}^2 + \left(\frac{m_1}{m_2} \right) p_{2f}^2$$

We don't care about v_{1f} , so get rid of p_{1f} using $p_{1f} = p_{1i} - p_{2f}$

$$p_{1i}^2 = (p_{1i} - p_{2f})^2 + \frac{m_1}{m_2} p_{2f}^2$$

$$p_{1i}^2 = p_{1i}^2 - 2p_{1i}p_{2f} + p_{2f}^2 + \frac{m_1}{m_2} p_{2f}^2$$

$$2p_{1i}p_{2f} = \left(1 + \frac{m_1}{m_2} \right) p_{2f}^2$$

$$p_{1i} = \left(\frac{1}{2} \right) \left(1 + \frac{m_1}{m_2} \right) p_{2f}$$

$$m_1 v_{1i} = \left(\frac{1}{2} \right) (m_2 + m_1) v_{2f}$$

$$v_{1i} = \left(\frac{1}{2} \right) \left(\frac{m_2}{m_1} + 1 \right) v_{2f}$$

Now consider the pendulum.

$$\frac{1}{2} m_2 v_{2f}^2 = m_2 gh$$

$$\text{or } v_{2f} = \sqrt{2gh}$$

$$\text{where } h = L(1 - \cos \theta)$$

$$\text{Thus, } v_{2f} = \sqrt{2gL(1 - \cos \theta)}$$

$$\begin{aligned} v_{2f} &= \sqrt{(2)(9.80 \text{ m/s}^2)(1.25 \text{ m})(1 - \cos 37.0^\circ)} \\ &= 2.22 \text{ m/s} \end{aligned}$$



Chapter 11 continued

$$\begin{aligned}v_{1i} &= \frac{1}{2} \left(\frac{125 \text{ g}}{25 \text{ g}} + 1 \right) (2.22 \text{ m/s}) \\ &= 6.7 \text{ m/s}\end{aligned}$$

Writing in Physics

page 310

98. All energy comes from the Sun. In what forms has this solar energy come to us to allow us to live and to operate our society? Research the ways that the Sun's energy is turned into a form that we can use. After we use the Sun's energy, where does it go? Explain.

The Sun produces energy through nuclear fusion and releases that energy in the form of electromagnetic radiation, which is transferred through the vacuum of space to Earth. Earth absorbs that electromagnetic radiation in its atmosphere, land, and oceans in the form of thermal energy or heat. Part of the visible radiation also is converted by plants into chemical energy through photosynthesis. There are several other chemical reactions mediated by sunlight, such as ozone production. The energy then is transferred into various forms, some of which are the chemical processes that allow us to digest food and turn it into chemical energy to build tissues, to move, and to think. In the end, after we have used the energy, the remainder is dispersed as electromagnetic radiation back into the universe.

99. All forms of energy can be classified as either kinetic or potential energy. How would you describe nuclear, electric, chemical, biological, solar, and light energy, and why? For each of these types of energy, research what objects are moving and how energy is stored in those objects.

Potential energy is stored in the binding of the protons and neutrons in the nucleus. The energy is released when a heavy nucleus is broken into smaller pieces (fission) or when very small nuclei are combined to make bigger nuclei (fusion). In the same way, chemical potential energy is stored when atoms are combined to

make molecules and released when the molecules are broken up or rearranged. Separation of electric charges produces electric potential energy, as in a battery. Electric potential energy is converted to kinetic energy in the motion of electric charges in an electric current when a conductive path, or circuit, is provided. Biological processes are all chemical, and thus, biological energy is just a form of chemical energy. Solar energy is fusion energy converted to electromagnetic radiation. (See the answer to the previous question.) Light is a wave form of electromagnetic energy whose frequency is in a range detectible by the human eye.

Cumulative Review

page 310

100. A satellite is placed in a circular orbit with a radius of $1.0 \times 10^7 \text{ m}$ and a period of $9.9 \times 10^3 \text{ s}$. Calculate the mass of Earth.

Hint: Gravity is the net force on such a satellite. Scientists have actually measured the mass of Earth this way. (Chapter 7)

$$F_{\text{net}} = \frac{m_s v^2}{r} = \frac{G m_s m_e}{r^2}$$

$$\text{Since, } v = \frac{2\pi r}{T}$$

$$\left(\frac{m_s}{r} \right) \left(\frac{4\pi^2 r^2}{T^2} \right) = \frac{G m_s m_e}{r^2}$$

$$m_e = \frac{4\pi^2 r^2}{G T^2}$$

$$= \frac{4\pi^2 (1.0 \times 10^7 \text{ m})^3}{(6.67 \times 10^{-11} \text{ N} \cdot \text{m}^2/\text{kg}^2) (9.9 \times 10^3 \text{ s})^2}$$

$$= 6.0 \times 10^{24} \text{ kg}$$

101. A 5.00-g bullet is fired with a velocity of 100.0 m/s toward a 10.00-kg stationary solid block resting on a frictionless surface. (Chapter 9)

- a. What is the change in momentum of the bullet if it is embedded in the block?

$$m_b v_{b1} = m_b v_2 - m_w v_2$$

$$= (m_b + m_w) v_2$$

Chapter 11 continued

$$\text{so } v_2 = \frac{m_b v_{b1}}{m_b + m_w}$$

Then,

$$\begin{aligned} \Delta p v &= m_b(v_2 - v_{b1}) \\ &= m_b\left(\frac{m_b v_{b1}}{m_b + m_w} - v_{b1}\right) \\ &= m_b v_{b1}\left(\frac{m_b}{m_b + m_w} - 1\right) \\ &= -\frac{m_b m_w}{m_b + m_w} v_{b1} \\ &= -\frac{(5.00 \times 10^{-3} \text{ kg})(10.00 \text{ kg})}{5.00 \times 10^{-3} \text{ kg} + 10.00 \text{ kg}} \\ &\quad (100.0 \text{ m/s}) \\ &= -0.500 \text{ kg}\cdot\text{m/s} \end{aligned}$$

- b. What is the change in momentum of the bullet if it ricochets in the opposite direction with a speed of 99 m/s?

$$\begin{aligned} \Delta p v &= m_b(v_2 - v_{b1}) \\ &= (5.00 \times 10^{-3} \text{ kg}) \\ &\quad (-99.0 \text{ m/s} - 100.0 \text{ m/s}) \\ &= -0.995 \text{ kg}\cdot\text{m/s} \end{aligned}$$

- c. In which case does the block end up with a greater speed?

When the bullet ricochets, its change in momentum is larger in magnitude, and so is the block's change in momentum, so the block ends up with a greater speed.

102. An automobile jack must exert a lifting force of at least 15 kN.

- a. If you want to limit the effort force to 0.10 kN, what mechanical advantage is needed?

$$MA = \frac{15 \text{ kN}}{0.10 \text{ kN}} = 150$$

- b. If the jack is 75% efficient, over what distance must the effort force be exerted in order to raise the auto 33 cm?

$$IMA = \frac{MA}{e} = 2.0 \times 10^2.$$

$$\text{Since } \frac{d_e}{d_r} = IMA,$$

$$\begin{aligned} d_e &= \frac{IMA}{d_r} = (2.0 \times 10^2)(33 \text{ cm}) \\ &= 66 \text{ m} \end{aligned}$$

Challenge Problem

page 300

A bullet of mass m , moving at speed v_1 , goes through a motionless wooden block and exits with speed v_2 . After the collision, the block, which has mass m_B , is moving.

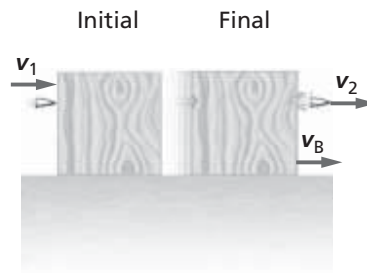

1. What is the final speed v_B of the block?

Conservation of momentum:

$$mv_1 = mv_2 + m_B v_B$$

$$m_B v_B = m(v_1 - v_2)$$

$$v_B = \frac{m(v_1 - v_2)}{m_B}$$

2. How much energy was lost to the bullet?

For the bullet alone:

$$KE_1 = \frac{1}{2} m v_1^2$$

$$KE_2 = \frac{1}{2} m v_2^2$$

$$\Delta KE = \frac{1}{2} m(v_1^2 - v_2^2)$$

3. How much energy was lost to friction inside the block?

Energy lost to friction = $KE_1 -$

$$KE_2 - KE_{\text{block}}$$

$$E_{\text{lost}} = \frac{1}{2} m v_1^2 - \frac{1}{2} m v_2^2 - \frac{1}{2} m_B v_B^2$$