

تم تحميل هذا الملف من موقع المناهج العُمانية



*للحصول على أوراق عمل لجميع الصفوف وجميع المواد اضغط هنا

<https://almanahj.com/om>

* للحصول على أوراق عمل لجميع مواد الصف السادس اضغط هنا

<https://almanahj.com/om/6>

* للحصول على جميع أوراق الصف السادس في مادة لغة انجليزية ولجميع الفصول, اضغط هنا

<https://almanahj.com/om/6english>

* للحصول على أوراق عمل لجميع مواد الصف السادس في مادة لغة انجليزية الخاصة بـ الفصل الأول اضغط هنا

<https://almanahj.com/om/6english1>

* لتحميل كتب جميع المواد في جميع الفصول للـ الصف السادس اضغط هنا

<https://almanahj.com/om/grade6>

* لتحميل جميع ملفات المدرس عمر العزري اضغط هنا

للتحدث إلى بوت على تلغرام: اضغط هنا

https://t.me/omcourse_bot

REGION:

2018/2019

ENGLISH LANGUAGE TEST

GRADE SIX

Semester One

First Session

Name			
School		Class	

Write your answers on the Test Paper

Time: 1 ½ hours

Pages: 11

TEST SCORES	LISTENING	10	
	GRM/VCB	10	
	READING	10	
	WRITING	10	
	TOTAL	40	

LISTENING 1 (Items 1-5)

(5 marks)

You are going to hear five short texts about **Jobs**. Match the pictures with the texts. For each text, shade in the bubble under the correct option.

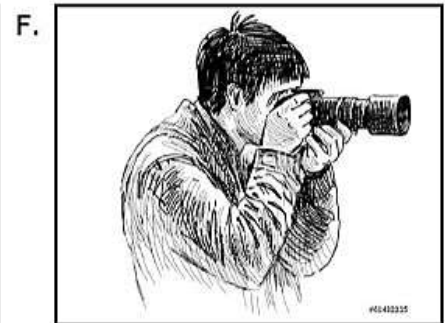
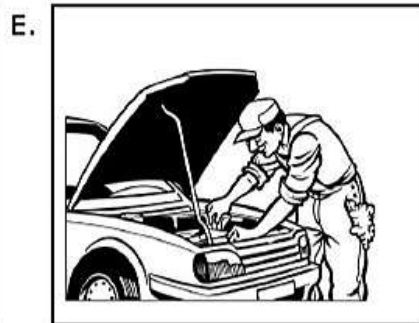
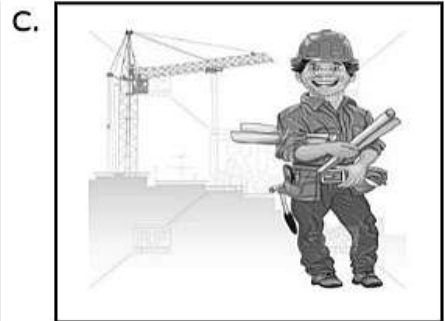
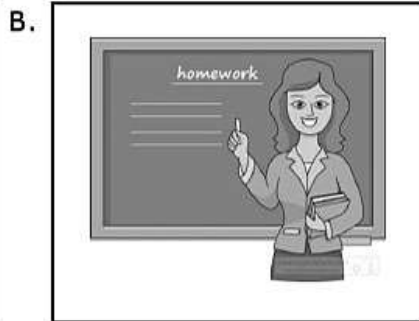
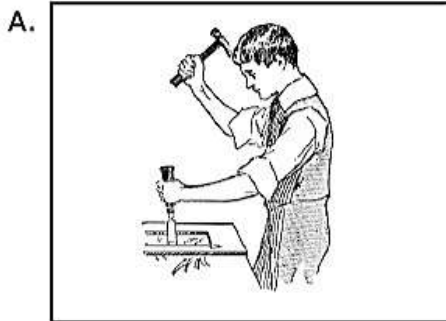

Pictures

Text	A	B	C	D	E	F
1.	<input type="radio"/>	<input type="radio"/>	<input type="radio"/>	<input type="radio"/>	<input type="radio"/>	<input type="radio"/>
2.	<input type="radio"/>	<input type="radio"/>	<input type="radio"/>	<input type="radio"/>	<input type="radio"/>	<input type="radio"/>
3.	<input type="radio"/>	<input type="radio"/>	<input type="radio"/>	<input type="radio"/>	<input type="radio"/>	<input type="radio"/>
4.	<input type="radio"/>	<input type="radio"/>	<input type="radio"/>	<input type="radio"/>	<input type="radio"/>	<input type="radio"/>
5.	<input type="radio"/>	<input type="radio"/>	<input type="radio"/>	<input type="radio"/>	<input type="radio"/>	<input type="radio"/>







LISTENING 2 (Items 6–10)

(5 marks)

You are going to hear **a text** about **Paul**.

Listen and complete the table with **√** or **×**.

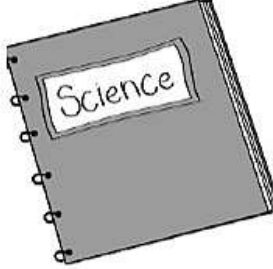
		
<p>(e.g.)</p> <p style="text-align: center;">√</p>	<p>(6)</p>	<p>(7)</p>
<p style="text-align: center;">SISTER</p>  <p style="text-align: center;">BROTHER</p>		
<p>(8)</p>	<p>(9)</p>	<p>(10)</p>



**LISTENING
SCORE**



10

GRAMMAR/VOCABULARY 1 (Items 1-5)

(2½ marks)

Match the pictures with the words. For each picture, shade in the bubble under the correct option

1.	2.	3.
		

4.	5.
	

ladder	angry	finger	rug	face	nurse	tent	pilot
--------	-------	--------	-----	------	-------	------	-------

1.	<input type="radio"/>	<input type="radio"/>	<input type="radio"/>	<input type="radio"/>	<input type="radio"/>	<input type="radio"/>	<input type="radio"/>	<input type="radio"/>
2.	<input type="radio"/>	<input type="radio"/>	<input type="radio"/>	<input type="radio"/>	<input type="radio"/>	<input type="radio"/>	<input type="radio"/>	<input type="radio"/>
3.	<input type="radio"/>	<input type="radio"/>	<input type="radio"/>	<input type="radio"/>	<input type="radio"/>	<input type="radio"/>	<input type="radio"/>	<input type="radio"/>
4.	<input type="radio"/>	<input type="radio"/>	<input type="radio"/>	<input type="radio"/>	<input type="radio"/>	<input type="radio"/>	<input type="radio"/>	<input type="radio"/>
5.	<input type="radio"/>	<input type="radio"/>	<input type="radio"/>	<input type="radio"/>	<input type="radio"/>	<input type="radio"/>	<input type="radio"/>	<input type="radio"/>

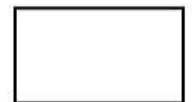

GRAMMAR/VOCABULARY 2 (Items 6–10)

(2½ marks)

Complete each sentence with **ONE** word only.

6. How _____ is this watch?
7. Ahmed likes _____ read a story before sleeping.
8. This necklace is made _____ silver.
9. _____ does your friend live?
10. Salem did not _____ to school because he was sick.

GRAMMAR/VOCABULARY 3 (Items 11–20)

(5 marks)

For each item, shade in the bubble **O** next to the correct option.

Hamed is (11) ____ good student. He (12)_____ twelve years old. He lives with his father, mother and (13)_____younger sister in a big (14)_____. He likes English. He wants to be an English (15)_____ in the future. He helps his friends (16) ____ speak English at school. He likes watching Tom and Jerry (17)_____ in his free time. His favourite (18)_____ is pizza . He doesn't like sweets (19)_____ chocolates. His father often takes him to the (20)_____ to buy an ice-cream.

- | | | | | |
|-----|---------------------------------|----------------------------------|-------------------------------|--------------------------------|
| 11. | <input type="radio"/> the | <input type="radio"/> an | <input type="radio"/> a | <input type="radio"/> some |
| 12. | <input type="radio"/> is | <input type="radio"/> are | <input type="radio"/> am | <input type="radio"/> were |
| 13. | <input type="radio"/> her | <input type="radio"/> him | <input type="radio"/> their | <input type="radio"/> his |
| 14. | <input type="radio"/> office | <input type="radio"/> house | <input type="radio"/> school | <input type="radio"/> hotel |
| 15. | <input type="radio"/> fisherman | <input type="radio"/> driver | <input type="radio"/> artist | <input type="radio"/> teacher |
| 16. | <input type="radio"/> to | <input type="radio"/> for | <input type="radio"/> at | <input type="radio"/> in |
| 17. | <input type="radio"/> magazines | <input type="radio"/> newspapers | <input type="radio"/> books | <input type="radio"/> cartoons |
| 18. | <input type="radio"/> sport | <input type="radio"/> food | <input type="radio"/> subject | <input type="radio"/> drink |
| 19. | <input type="radio"/> with | <input type="radio"/> because | <input type="radio"/> and | <input type="radio"/> but |
| 20. | <input type="radio"/> shop | <input type="radio"/> school | <input type="radio"/> clinic | <input type="radio"/> library |

--

**GRM/VCB
SCORE**

10

READING 1 (Items 1-5)

(5 marks)

For each picture, shade in the bubble next to the correct option.

1.



- He reads a newspaper.
- He reads a book.
- He reads a magazine.

2.



- He is a teacher.
- He is a policeman.
- He is a doctor.

3.

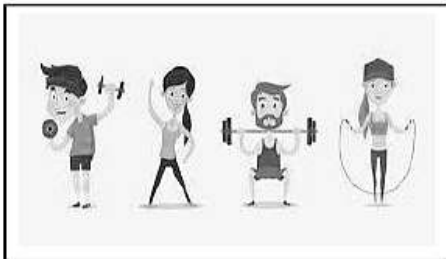

- They are exercising.
- They are swimming.
- They are cooking.

4.



- She rides a horse.
- She rides a bike.
- She rides a camel.

5.



- He is happy.
- He is sad.
- He is scared.



READING 2 (Items 6–15)

(5 marks)

Read the text. Are the statements **True** or **False**?

For each item, shade in the bubble under the correct option.

Laila Mohammed was an Omani doctor. She was born in Muscat in 1968. Her father was a poor farmer. He had a small farm. When she was 7 years old, her father took her to a school near her house. She was a good student and she was always at the top of her class. Maths and Science were her favourite subjects. When she finished school, she joined the university. She studied medicine and she became a doctor. She worked in the Royal Hospital in Muscat for ten years and she worked very hard. She felt happy because she looked after sick people. She got married and had two sons and a daughter. When she was 42 years old she became sick. She died in 2010.

Statements	True	False
6. Laila was from Oman.	<input type="radio"/>	<input type="radio"/>
7. She was born in Sohar.	<input type="radio"/>	<input type="radio"/>
8. Her father was a rich man	<input type="radio"/>	<input type="radio"/>
9. She liked Maths and Science.	<input type="radio"/>	<input type="radio"/>
10. She studied medicine in the university	<input type="radio"/>	<input type="radio"/>
11. She worked in Khoula Hospital.	<input type="radio"/>	<input type="radio"/>
12. She had two sons and two daughters.	<input type="radio"/>	<input type="radio"/>
13. She liked her job so much.	<input type="radio"/>	<input type="radio"/>
14. At the age of 40, she was sick	<input type="radio"/>	<input type="radio"/>
15. Laila died in 2010.	<input type="radio"/>	<input type="radio"/>

	<input style="width: 50px; height: 20px;" type="text"/>
READING SCORE	<input style="width: 50px; height: 20px;" type="text"/>
	<input style="width: 50px; height: 20px; text-align: center; font-weight: bold;" type="text" value="10"/>

WRITING 1

(2 marks)

Write these two sentences correctly. Put in capital letters and punctuation marks.

A.

i like playing football with my friends ahmed and nasser

B.

where did Ali go last weekend he went to nizwa.

Marker A	Marker B	Average

WRITING 2

(3 marks)

Look at the pictures. Then complete each sentence.



She _____



They _____



He _____

Marker A	Marker B	Average

WRITING 3

(5 marks)

Complete the following task. Write at least **40 words**.

Situation: Imagine that you are **Fahad/Farah**. Your friend became fat. Write an **e-mail** to advise him/her **how to keep fit and healthy**.

Your writing should be **clear and organized**

Marker A	Marker B	Average

WRITING SCORE	
	10

GRADE SIX — ENGLISH LANGUAGE
SEMESTER ONE, 2018/2019, FIRST SESSION

MARKING GUIDE
TOTAL MARKS: 40
 page 1 of 4

LISTENING 1 (5 mks)						LISTENING 2 (5 mks)			
	A	B	C	D	E	F		6.	7.
1.	<input type="radio"/>	<input type="radio"/>	<input type="radio"/>	<input checked="" type="radio"/>	<input checked="" type="radio"/>	<input type="radio"/>	(e.g.)		
2.	<input type="radio"/>	<input type="radio"/>	<input checked="" type="radio"/>	<input type="radio"/>	<input type="radio"/>	<input checked="" type="radio"/>	√	x	√
3.	<input checked="" type="radio"/>	<input type="radio"/>	<input checked="" type="radio"/>	<input type="radio"/>	<input type="radio"/>	<input type="radio"/>	8.	9.	10.
4.	<input checked="" type="radio"/>	<input type="radio"/>	<input type="radio"/>	<input checked="" type="radio"/>	<input type="radio"/>	<input type="radio"/>	x	x	√
5.	<input type="radio"/>	<input type="radio"/>	<input type="radio"/>	<input type="radio"/>	<input checked="" type="radio"/>	<input checked="" type="radio"/>			

Notes: One mark each. Responses must be indicated clearly.

GRM/ VCB 1 (2.5 mks)								
	ladder	angry	finger	rug	face	nurse	tent	pilot
1.	<input type="radio"/>	<input type="radio"/>	<input type="radio"/>	<input checked="" type="radio"/>	<input type="radio"/>	<input type="radio"/>	<input type="radio"/>	<input type="radio"/>
2.	<input type="radio"/>	<input type="radio"/>	<input type="radio"/>	<input type="radio"/>	<input type="radio"/>	<input type="radio"/>	<input checked="" type="radio"/>	<input type="radio"/>
3.	<input type="radio"/>	<input checked="" type="radio"/>	<input type="radio"/>	<input type="radio"/>	<input type="radio"/>	<input type="radio"/>	<input type="radio"/>	<input type="radio"/>
4.	<input checked="" type="radio"/>	<input type="radio"/>	<input type="radio"/>	<input type="radio"/>	<input type="radio"/>	<input type="radio"/>	<input type="radio"/>	<input type="radio"/>
5.	<input type="radio"/>	<input type="radio"/>	<input type="radio"/>	<input type="radio"/>	<input type="radio"/>	<input checked="" type="radio"/>	<input type="radio"/>	<input type="radio"/>

Notes: Half-a-mark each. Responses must be indicated clearly.

GRM/ VCB 2 (2.5 mks)	
6.	much
7.	to
8.	of
9.	Where
10.	go

Notes: Half-a-mark each. Spelling must be correct, including grammatical endings.

GRM/ VCB 3 (5 mks)								
11.	<input type="radio"/>	the	<input type="radio"/>	an	<input checked="" type="radio"/>	a	<input type="radio"/>	some
12.	<input checked="" type="radio"/>	is	<input type="radio"/>	are	<input type="radio"/>	am	<input type="radio"/>	were
13.	<input type="radio"/>	her	<input type="radio"/>	him	<input type="radio"/>	their	<input checked="" type="radio"/>	his
14.	<input type="radio"/>	office	<input checked="" type="radio"/>	house	<input type="radio"/>	school	<input type="radio"/>	hotel
15.	<input type="radio"/>	fisherman	<input type="radio"/>	driver	<input type="radio"/>	artist	<input checked="" type="radio"/>	teacher
16.	<input checked="" type="radio"/>	to	<input type="radio"/>	for	<input type="radio"/>	at	<input type="radio"/>	in
17.	<input type="radio"/>	magazines	<input type="radio"/>	newspapers	<input type="radio"/>	books	<input checked="" type="radio"/>	cartoons
18.	<input type="radio"/>	sport	<input checked="" type="radio"/>	food	<input type="radio"/>	subject	<input type="radio"/>	drink
19.	<input type="radio"/>	with	<input type="radio"/>	because	<input checked="" type="radio"/>	and	<input type="radio"/>	but
20.	<input checked="" type="radio"/>	shop	<input type="radio"/>	school	<input type="radio"/>	clinic	<input type="radio"/>	library

Notes: Half-a-mark each. Responses must be indicated clearly.

READING 1 (5 mks)		READING 2 (5 mks)	
1.	<input checked="" type="radio"/> He reads a newspaper. <input type="radio"/> He reads a book. <input type="radio"/> He reads a magazine.	6.	True: <input checked="" type="radio"/> False: <input type="radio"/>
2.	<input type="radio"/> He is a teacher. <input checked="" type="radio"/> He is a policeman. <input type="radio"/> He is a doctor.	7.	True: <input type="radio"/> False: <input checked="" type="radio"/>
3.	<input checked="" type="radio"/> They are exercising. <input type="radio"/> They are swimming. <input type="radio"/> They are cooking.	8.	True: <input type="radio"/> False: <input checked="" type="radio"/>
4.	<input type="radio"/> She rides a horse. <input checked="" type="radio"/> She rides a bike. <input type="radio"/> She rides a camel.	9.	True: <input checked="" type="radio"/> False: <input type="radio"/>
5.	<input type="radio"/> He is happy. <input type="radio"/> He is sad. <input checked="" type="radio"/> He is scared.	10.	True: <input checked="" type="radio"/> False: <input type="radio"/>
		11.	True: <input type="radio"/> False: <input checked="" type="radio"/>
		12.	True: <input type="radio"/> False: <input checked="" type="radio"/>
		13.	True: <input checked="" type="radio"/> False: <input type="radio"/>
		14.	True: <input type="radio"/> False: <input checked="" type="radio"/>
		15.	True: <input checked="" type="radio"/> False: <input type="radio"/>
Notes: One mark each. Responses must be indicated <u>clearly</u> .		Notes: Half-a-mark each. Responses must be indicated <u>clearly</u> .	

WRITING 1 (2 mks)		Criteria:
2	Very good.	<p>Consider the overall quality of the punctuation and use of capital letters in the two sentences as a whole:</p> <ul style="list-style-type: none"> – Have all the correct punctuation marks and capital letters been inserted in the correct places? – Have any been inserted that should <u>not</u> be there? <p>Sentence A: I like playing football with my friends Ahmed and Nasser.</p> <p>Sentence B: Where did Ali go last weekend? He went to Nizwa.</p>
1.5	Good.	
1	Adequate. (Just good enough)	
0.5	Inadequate. (Not good enough)	
0	No attempt at the task.	
###	#####	
###	#####	

WRITING 2 (3 mks)		Criteria:
3	Very good.	<p>Consider the overall quality of the three sentences as a whole:</p> <ul style="list-style-type: none"> – Do the sentences <u>make sense</u>? [<i>Is the meaning clear?</i>] – How much <u>relevant information</u> do the sentences communicate? [<i>Are the sentences extremely simple, or does the student try to say a little more about the pictures?</i>] – Is the <u>language</u> in the sentences <u>correct</u>? [<i>Is the grammar/ vocabulary/ spelling/ punctuation (mostly) correct?</i>]
2.5	Good.	
2	Quite good.	
1.5	Adequate. (Just good enough)	
1	Inadequate. (Not good enough)	
0.5	A <u>very weak</u> attempt at the task.	
0	No attempt at the task.	

WRITING 3 (5 mks)	
5	<ul style="list-style-type: none"> - Task achievement is <u>very good</u>. - Meaning is very clear. - Grammar/ Vocab are correct and appropriate. - Spelling and punctuation are very good.
4	<ul style="list-style-type: none"> - Task achievement is <u>good</u>. - Meaning is almost always clear. - Grammar/ Vocab are mostly correct and appropriate. - Spelling and punctuation are good.
3	<ul style="list-style-type: none"> - Task achievement is <u>adequate</u>. - Meaning is clear enough. - Grammar/ Vocab are reasonably correct and appropriate. - Spelling and punctuation are reasonably good.
2	<ul style="list-style-type: none"> - Task achievement is <u>inadequate</u>. - Meaning is sometimes unclear. - Grammar/ Vocab are quite often incorrect or inappropriate. - Spelling and punctuation are often inaccurate.
1	<ul style="list-style-type: none"> - Task achievement is <u>poor</u>. - Meaning is often unclear. - Grammar/ Vocab are very often incorrect and inappropriate. - Spelling and punctuation are very poor.
0	<p><u>No attempt at the task</u>: <u>EITHER</u> Irrelevant (Completely unrelated to the task/ instructions) <u>OR</u> Just copied from the Q-paper <u>OR</u> Hardly any writing at all, or not written in English <u>OR</u> Complete nonsense</p>

2018/2019

ENGLISH LANGUAGE TEST

GRADE SIX

**Semester One
second Session**

Name			
School		Class	

Write your answers on the Test Paper

Time: 1 ½ hours

Pages: 11

TEST SCORES	LISTENING	10	
	GRM/VCB	10	
	READING	10	
	WRITING	10	
	TOTAL	40	

LISTENING 1 (Items 1-5)

(5 marks)

You are going to hear five short texts about **Patterns**. Match the pictures with the texts. For each text, shade in the bubble under the correct option.

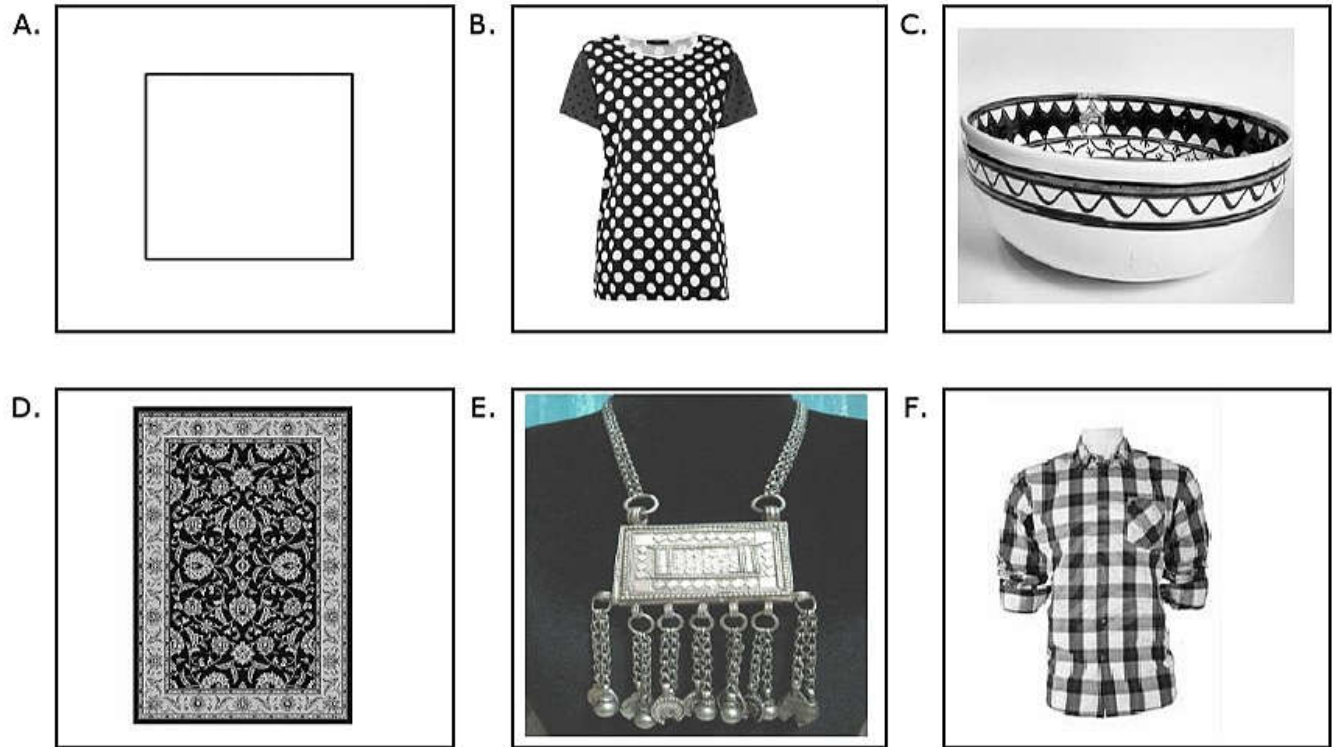

Pictures

Text	A	B	C	D	E	F
1.	<input type="radio"/>	<input type="radio"/>	<input type="radio"/>	<input type="radio"/>	<input type="radio"/>	<input type="radio"/>
2.	<input type="radio"/>	<input type="radio"/>	<input type="radio"/>	<input type="radio"/>	<input type="radio"/>	<input type="radio"/>
3.	<input type="radio"/>	<input type="radio"/>	<input type="radio"/>	<input type="radio"/>	<input type="radio"/>	<input type="radio"/>
4.	<input type="radio"/>	<input type="radio"/>	<input type="radio"/>	<input type="radio"/>	<input type="radio"/>	<input type="radio"/>
5.	<input type="radio"/>	<input type="radio"/>	<input type="radio"/>	<input type="radio"/>	<input type="radio"/>	<input type="radio"/>







LISTENING 2 (Items 6–10)

(5 marks)

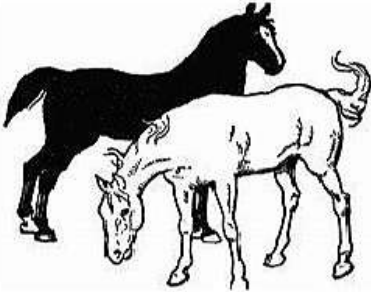
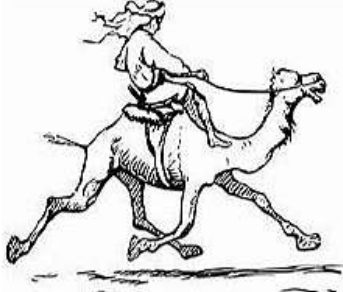
You are going to hear **a text about Issa.**

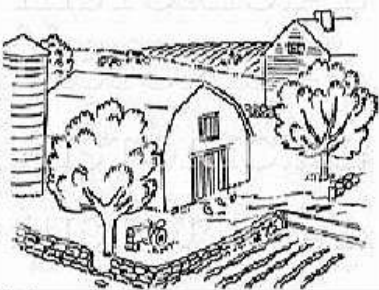
Listen and complete the table with **✓** or **×**

		
<p>(e.g.)</p> <p style="text-align: center;">✓</p>	<p>(6)</p>	<p>(7)</p>
		
<p>(8)</p>	<p>(9)</p>	<p>(10)</p>



**LISTENING
SCORE**



10

GRAMMAR/VOCABULARY 1 (Items 1-5)

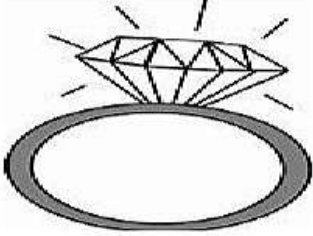
(2½ marks)

Match the pictures with the words. For each picture, shade in the bubble under the correct option.

1.	2.	3.
		

4.	5.
	

	string	waiter	finger	ring	tent	map	face	pilot
--	--------	--------	--------	------	------	-----	------	-------

1.	<input type="radio"/>	<input type="radio"/>	<input type="radio"/>	<input type="radio"/>	<input type="radio"/>	<input type="radio"/>	<input type="radio"/>	<input type="radio"/>
2.	<input type="radio"/>	<input type="radio"/>	<input type="radio"/>	<input type="radio"/>	<input type="radio"/>	<input type="radio"/>	<input type="radio"/>	<input type="radio"/>
3.	<input type="radio"/>	<input type="radio"/>	<input type="radio"/>	<input type="radio"/>	<input type="radio"/>	<input type="radio"/>	<input type="radio"/>	<input type="radio"/>
4.	<input type="radio"/>	<input type="radio"/>	<input type="radio"/>	<input type="radio"/>	<input type="radio"/>	<input type="radio"/>	<input type="radio"/>	<input type="radio"/>
5.	<input type="radio"/>	<input type="radio"/>	<input type="radio"/>	<input type="radio"/>	<input type="radio"/>	<input type="radio"/>	<input type="radio"/>	<input type="radio"/>



GRAMMAR/VOCABULARY 2 (Items 6–10)

(2½ marks)

Complete each sentence with **ONE** word only.

6. Yesterday I bought _____ ice-cream from the shop.

7. _____ are you from? I'm from the USA.

8. There _____ two books and three pens on the desk.

9. I'm going _____ the park.

10. How _____ brothers have you got?

GRAMMAR/VOCABULARY 3 (Items 11–20)

(5 marks)

For each item, shade in the bubble **○** next to the correct option.

Everyday ⁽¹¹⁾ _____ I go to bed, I usually wear ⁽¹²⁾ _____ favourite pajamas. I got it ⁽¹³⁾ _____ my uncle. I love it because it ⁽¹⁴⁾ _____ blue and white ⁽¹⁵⁾ _____. Then I go to the ⁽¹⁶⁾ _____ to wash my face and brush my ⁽¹⁷⁾ _____. After that, I ⁽¹⁸⁾ _____ a story for fifteen minutes. Finally I turn off the ⁽¹⁹⁾ _____ and go to ⁽²⁰⁾ _____.

- | | | | | |
|-----|--------------------------------|-------------------------------|---------------------------------|-----------------------------------|
| 11. | <input type="radio"/> after | <input type="radio"/> before | <input type="radio"/> later | <input type="radio"/> at |
| 12. | <input type="radio"/> his | <input type="radio"/> her | <input type="radio"/> their | <input type="radio"/> my |
| 13. | <input type="radio"/> from | <input type="radio"/> to | <input type="radio"/> on | <input type="radio"/> at |
| 14. | <input type="radio"/> have | <input type="radio"/> hasn't | <input type="radio"/> has | <input type="radio"/> haven't |
| 15. | <input type="radio"/> parts | <input type="radio"/> colours | <input type="radio"/> shapes | <input type="radio"/> papers |
| 16. | <input type="radio"/> bathroom | <input type="radio"/> bedroom | <input type="radio"/> classroom | <input type="radio"/> dining room |
| 17. | <input type="radio"/> nose | <input type="radio"/> eyes | <input type="radio"/> hair | <input type="radio"/> teeth |
| 18. | <input type="radio"/> listen | <input type="radio"/> look | <input type="radio"/> read | <input type="radio"/> work |
| 19. | <input type="radio"/> lights | <input type="radio"/> door | <input type="radio"/> window | <input type="radio"/> clock |
| 20. | <input type="radio"/> swim | <input type="radio"/> sleep | <input type="radio"/> climb | <input type="radio"/> run |

--

**GRM/VCB
SCORE**

10

READING 1 (Items 1-5)

(5 marks)

For each picture, shade in the bubble next to the correct option.



- He is angry.
- He is happy.
- He is sad.

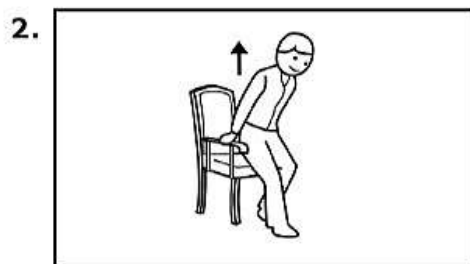

- Stand up.
- Sit down.
- Bend your head.



- It's a compass.
- It's a mirror.
- It's a telescope.

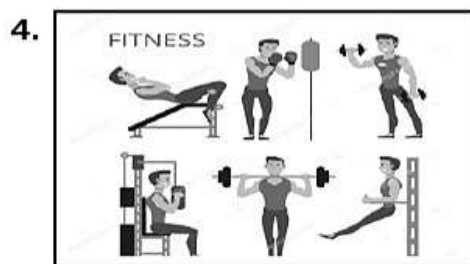

- He is in the gym.
- He is in the hospital.
- He is in the library.

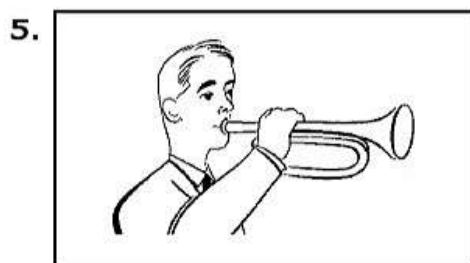

- He is playing tennis.
- He is playing music.
- He is playing chess.



READING 2 (Items 6–15)

(5 marks)

Read the text. Are the statements **True** or **False**?

For each item, shade in the bubble under the correct option.

Salim's last summer holiday started at the end of May. He and his parents went to Masirah Island. They got there by boat. The boat was very nice. They spent their time reading books and magazines, listening to music and looking through the window. They arrived at 7:30 in the evening. They stayed in a nice hotel near the beach. The room was very big with three beds. Next day, they went to the beach. Salim met some boys and they became friends. They swam in the sea. After that, they played volleyball on the beach. His father played with them. His mother sat under the umbrella and read a book. It was a fantastic holiday. Salim dreams of going there again.

READING 2 (continued)

Statements	True	False
6. Salim's holiday was in April.	<input type="radio"/>	<input type="radio"/>
7. He went with his parents.	<input type="radio"/>	<input type="radio"/>
8. They went to the beach by car.	<input type="radio"/>	<input type="radio"/>
9. He spent his time in the boat watching TV.	<input type="radio"/>	<input type="radio"/>
10. They arrived at the beach in the evening.	<input type="radio"/>	<input type="radio"/>
11. They stayed in his uncle's house.	<input type="radio"/>	<input type="radio"/>
12. Their room was very big.	<input type="radio"/>	<input type="radio"/>
13. Salim swam in the sea.	<input type="radio"/>	<input type="radio"/>
14. His mother sat under a tree.	<input type="radio"/>	<input type="radio"/>
15. He enjoyed his holiday.	<input type="radio"/>	<input type="radio"/>

READING SCORE	10

WRITING 1

(2 marks)

Write these two sentences correctly. Put in **capital letters and punctuation marks**.

A. on monday fatma and ali visited their grandmother.

B. do you like swimming Yes, i do

Marker A	Marker B	Average

WRITING 2

(3 marks)

Look at the pictures. Then complete each sentence.



She _____

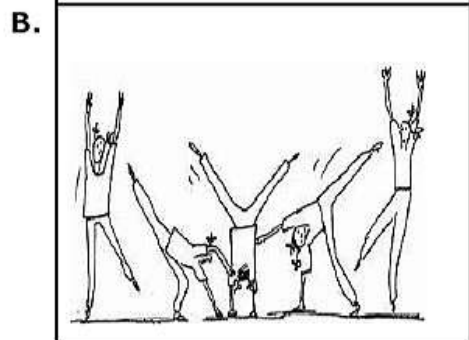

They _____



He _____

Marker A	Marker B	Average

WRITING 3

(5 marks)

*Complete the following task. Write at least **40 words**.*

Situation: It's your **birthday** next week and you're having a party. You want to **invite** your friend Amir/Amira. Write an e-mail to invite him/her to the party. Tell him/her **when it is and how to get to your house** .

*Your writing should be **clear and organized**.*

Marker A	Marker B	Average

WRITING SCORE	
	10

Listening Script for grade 6

Listening 1

1. At Eid many Omani women wear long silver necklace with a rectangle box. It looks beautiful.
2. Palestinian pottery usually has a strong zigzag pattern. Many tourists like to buy them and take them home as souvenirs.
3. If you want to make an origami frog, first take a square piece of paper. Then fold it.
4. Iran is famous for making rugs. Their rugs have pattern with flowers. They are very expensive.
5. Last week was my brother's birthday. I bought a wonderful checked t- shirt for him as a gift .

Listening 2

My grandfather Issa

This is my grandfather Issa. He is 60 years old. He lives in Salalah . He likes to keep camels in his big farm .He enjoys watching camels races . He takes his camels to the race every Thursday. Last year he won the third place and they gave him 2 thousand rails .He was very happy and excited. He also likes to make traditional crafts such as, Omani silver khanjars. Therefore, he has a small shop for making traditional crafts. Many tourists visit his shop to buy crafts and take some photographs .He has a big house near the beach. In the evening he likes to sit with his friends and drink coffee .They talk ,laugh and have fun.

GRADE SIX — ENGLISH LANGUAGE
SEMESTER ONE, 2018/2019, SECOND SESSION

MARKING GUIDE
TOTAL MARKS: 40
 page 1 of 4

LISTENING 1 (5 mks)						LISTENING 2 (5 mks)			
	A	B	C	D	E	F		6.	7.
1.	<input type="radio"/>	<input type="radio"/>	<input type="radio"/>	<input type="radio"/>	<input checked="" type="radio"/>	<input type="radio"/>	(e.g.)		
2.	<input type="radio"/>	<input type="radio"/>	<input checked="" type="radio"/>	<input type="radio"/>	<input type="radio"/>	<input type="radio"/>	√	x	√
3.	<input checked="" type="radio"/>	<input type="radio"/>	<input type="radio"/>	<input type="radio"/>	<input type="radio"/>	<input type="radio"/>	8.	9.	10.
4.	<input type="radio"/>	<input type="radio"/>	<input type="radio"/>	<input checked="" type="radio"/>	<input type="radio"/>	<input type="radio"/>	√	x	√
5.	<input type="radio"/>	<input type="radio"/>	<input type="radio"/>	<input type="radio"/>	<input type="radio"/>	<input checked="" type="radio"/>			

Notes: One mark each. Responses must be indicated clearly.

GRM/ VCB 1 (2.5 mks)								
	string	waiter	finger	ring	tent	map	face	pilot
1.	<input type="radio"/>	<input type="radio"/>	<input type="radio"/>	<input checked="" type="radio"/>	<input type="radio"/>	<input type="radio"/>	<input type="radio"/>	<input type="radio"/>
2.	<input type="radio"/>	<input type="radio"/>	<input type="radio"/>	<input type="radio"/>	<input type="radio"/>	<input type="radio"/>	<input checked="" type="radio"/>	<input type="radio"/>
3.	<input type="radio"/>	<input checked="" type="radio"/>	<input type="radio"/>	<input type="radio"/>	<input type="radio"/>	<input type="radio"/>	<input type="radio"/>	<input type="radio"/>
4.	<input checked="" type="radio"/>	<input type="radio"/>	<input type="radio"/>	<input type="radio"/>	<input type="radio"/>	<input type="radio"/>	<input type="radio"/>	<input type="radio"/>
5.	<input type="radio"/>	<input type="radio"/>	<input type="radio"/>	<input type="radio"/>	<input type="radio"/>	<input checked="" type="radio"/>	<input type="radio"/>	<input type="radio"/>

Notes: Half-a-mark each. Responses must be indicated clearly.

GRM/ VCB 2 (2.5 mks)	
6.	an
7.	Where
8.	are
9.	to
10.	many

Notes: Half-a-mark each. Spelling must be correct, including grammatical endings.

GRM/ VCB 3 (5 mks)								
11.	<input type="radio"/>	after	<input checked="" type="radio"/>	before	<input type="radio"/>	later	<input type="radio"/>	at
12.	<input type="radio"/>	his	<input type="radio"/>	her	<input type="radio"/>	their	<input checked="" type="radio"/>	my
13.	<input checked="" type="radio"/>	from	<input type="radio"/>	to	<input type="radio"/>	on	<input type="radio"/>	at
14.	<input type="radio"/>	have	<input type="radio"/>	hasn't	<input checked="" type="radio"/>	has	<input type="radio"/>	haven't
15.	<input type="radio"/>	parts	<input checked="" type="radio"/>	colours	<input type="radio"/>	shapes	<input type="radio"/>	papers
16.	<input checked="" type="radio"/>	bathroom	<input type="radio"/>	bedroom	<input type="radio"/>	classroom	<input type="radio"/>	dining room
17.	<input type="radio"/>	nose	<input type="radio"/>	eyes	<input type="radio"/>	hair	<input checked="" type="radio"/>	teeth
18.	<input type="radio"/>	listen	<input type="radio"/>	look	<input checked="" type="radio"/>	read	<input type="radio"/>	work
19.	<input checked="" type="radio"/>	lights	<input type="radio"/>	door	<input type="radio"/>	window	<input type="radio"/>	clock
20.	<input type="radio"/>	swim	<input checked="" type="radio"/>	sleep	<input type="radio"/>	climb	<input type="radio"/>	run

Notes: Half-a-mark each. Responses must be indicated clearly.

READING 1 (5 mks)		READING 2 (5 mks)	
1.	<input type="radio"/> He is angry. <input type="radio"/> He is happy. <input checked="" type="radio"/> He is sad.	6.	True: <input type="radio"/> False: <input checked="" type="radio"/>
2.	<input checked="" type="radio"/> Stand up. <input type="radio"/> Sit down. <input type="radio"/> Bend your head.	7.	True: <input checked="" type="radio"/> False: <input type="radio"/>
3.	<input type="radio"/> It's a compass. <input checked="" type="radio"/> It's a mirror. <input type="radio"/> It's a telescope.	8.	True: <input type="radio"/> False: <input checked="" type="radio"/>
4.	<input checked="" type="radio"/> He in the gym. <input type="radio"/> He is in the hospital. <input type="radio"/> He is in the library.	9.	True: <input type="radio"/> False: <input checked="" type="radio"/>
5.	<input type="radio"/> He is playing drums. <input checked="" type="radio"/> He is playing music. <input type="radio"/> He is playing chess.	10.	True: <input checked="" type="radio"/> False: <input type="radio"/>
		11.	True: <input type="radio"/> False: <input checked="" type="radio"/>
		12.	True: <input checked="" type="radio"/> False: <input type="radio"/>
		13.	True: <input checked="" type="radio"/> False: <input type="radio"/>
		14.	True: <input type="radio"/> False: <input checked="" type="radio"/>
		15.	True: <input checked="" type="radio"/> False: <input type="radio"/>

Notes: One mark each. Responses must be indicated clearly.

Notes: Half-a-mark each. Responses must be indicated clearly.

WRITING 1 (2 mks)		Criteria:
2	Very good.	<p>Consider the overall quality of the punctuation and use of capital letters in the two sentences as a whole:</p> <ul style="list-style-type: none"> – Have all the correct punctuation marks and capital letters been inserted in the correct places? – Have any been inserted that should <u>not</u> be there? <p>Sentence A: On Monday Fatma and Ali visited their grandmother.</p> <p>Sentence B: Do you like swimming? Yes, I do.</p>
1.5	Good.	
1	Adequate. (Just good enough)	
0.5	Inadequate. (Not good enough)	
0	No attempt at the task.	
###	#####	
###	#####	

WRITING 2 (3 mks)		Criteria:
3	Very good.	<p>Consider the overall quality of the three sentences as a whole:</p> <ul style="list-style-type: none"> – Do the sentences <u>make sense</u>? [<i>Is the meaning clear?</i>] – How much <u>relevant information</u> do the sentences communicate? [<i>Are the sentences extremely simple, or does the student try to say a little more about the pictures?</i>] – Is the <u>language</u> in the sentences <u>correct</u>? [<i>Is the grammar/ vocabulary/ spelling/ punctuation (mostly) correct?</i>]
2.5	Good.	
2	Quite good.	
1.5	Adequate. (Just good enough)	
1	Inadequate. (Not good enough)	
0.5	A <u>very weak</u> attempt at the task.	
0	No attempt at the task.	

WRITING 3 (5 mks)	
5	<ul style="list-style-type: none"> - Task achievement is <u>very good</u>. - Meaning is very clear. - Grammar/ Vocab are correct and appropriate. - Spelling and punctuation are very good.
4	<ul style="list-style-type: none"> - Task achievement is <u>good</u>. - Meaning is almost always clear. - Grammar/ Vocab are mostly correct and appropriate. - Spelling and punctuation are good.
3	<ul style="list-style-type: none"> - Task achievement is <u>adequate</u>. - Meaning is clear enough. - Grammar/ Vocab are reasonably correct and appropriate. - Spelling and punctuation are reasonably good.
2	<ul style="list-style-type: none"> - Task achievement is <u>inadequate</u>. - Meaning is sometimes unclear. - Grammar/ Vocab are quite often incorrect or inappropriate. - Spelling and punctuation are often inaccurate.
1	<ul style="list-style-type: none"> - Task achievement is <u>poor</u>. - Meaning is often unclear. - Grammar/ Vocab are very often incorrect and inappropriate. - Spelling and punctuation are very poor.
0	<p><u>No attempt at the task</u>: <u>EITHER</u> Irrelevant (Completely unrelated to the task/ instructions) <u>OR</u> Just copied from the Q-paper <u>OR</u> Hardly any writing at all, or not written in English <u>OR</u> Complete nonsense</p>